



Operation Manual

AS/NZS 1418.10

S0607E II /S0808E II

S0812E II /S1012E II

S1212E II /S1413E II

**Mobile Elevating
Work Platforms**

PART No. OM-2537050417

Original Instructions

Original Instructions

Thank you for choosing to use this Mobile Elevating Work Platform from LGMG, All models are designed and manufactured according to AS/NZS 1418.10, All dealers, owners, users, operators, lessors, lessees, and brokers to comply with appropriate section(s) of applicable AS/NZS 1418.10 standards.

This manual is a guide for safe and proper operation and maintenance of the machine, which introduces technical parameters and mechanism and operation herein.

We sincerely hope that you will read through this manual before attempting to operate the machine for the first time and before repairing and maintaining the machine, and that you will master the operation and maintenance described therein.

The information contained in this manual is correct at the time of publication. However, LGMG has endeavored to deliver the highest degree of accuracy possible. And continuous improvement of our product is a LGMG policy. Therefore, product specifications are subject to change without notice.

Due to the impossibility of foreseeing all possible hazards, therefore, it is not possible to include all safety precautions in this manual and the machine's safety precautions in this manual and the machine's safety instructions. If some operations that are not recommended in this manual, you must ensure that you and others are safe and will not damage the machine. If the security of certain operations cannot be determined, please call LGMG industries or dealer service center.

The precautions for operation and maintenance contained in this manual are only applicable when the machine is used for the specified use. If the machine is used within the scope not listed in this manual, our company will not assume any safety responsibility, which is borne by the user and operator in such operations.

Any prohibited operations in this manual shall not be performed.

This manual should always be placed in the designated location for read. This manual is part of the machine, when the ownership or use right of the machine is transferred, please hand over this manual together. If the manual is lost, damaged or illegible, please replace it promptly.

The copyright of this manual this manual is authorized to LGMG and it cannot be copied or reprinted without LGMG's written permission.

2024-06 Version 1 Printed 1

L I N G O N G H E A V Y M A C H I N E R Y C O . , L T D .

Add: 2676 Kejia Road, high tech Zone, Jinan City, Shandong Province, China

Tel: 86-0531-67601108

Fax: 86-0531-67601108

Service Tel: 86-0531-67605016

Web: www.lgmg.com.cn



Safety Precautions

The operator of this machine shall understand and follow the existing safety regulations of state and local governments. If these are unavailable, the safety instructions in this manual shall be followed.

To help prevent accidents, read and understand all warnings and precautions in this manual before operation or performing maintenance.

The safety measures are specified in Chapter 1 Safety.

It is impossible to foresee every possible hazard and the safety instructions in this manual may not cover all safety prevention measures. Always ensure the safety of all personnel and protect the machine against any damage. If unable to confirm the safety of some operations, contact LGMG.

The operation & maintenance prevention measures listed in this manual are only applicable to the specified uses of this machine. LGMG assumes no responsibility if this machine is used beyond the range of this manual. The user and the operator shall be responsible for the safety of such operations.

Do not perform any operation forbidden in this manual in any situation.

The following signal words are applicable for identifying the level of safety information in this manual.

 **DANGER:**

An imminent situation, that if not avoided, will result in severe injuries or death. This is also applicable to situations that will cause serious machine damage, if not avoided.

 **WARNING:**

A potentially dangerous situation, that if not avoided, may result in severe injuries or death. This is also applicable to situations that may cause serious machine damage, if not avoided.

 **NOTICE:**

A situation, that if not avoided, may result in minor or intermediate injury. This is also applicable to situations that may cause machine damage or shorten machine service life.





Contents

Safety Precautions.....	I
Contents	I
Chapter 1 Safety	1
1.1 Description	2
1.2 Maintenance of Safety Signs and Decals	2
1.3 Workstation Safety	2
1.4 Battery Safety.....	7
1.5 Lock After Each Use	8
Chapter 2 Machine Nomenclature	9
Chapter 3 Controls.....	11
3.1 Ground Controls	11
3.2 Platform Controls.....	12
Chapter 4 Pre-Operation Inspection.....	15
4.1 Basic Principles	15
4.2 Pre-Operation Inspection	15
Chapter 5 Workstation Inspection.....	17
5.1 General Information	17
5.2 Workstation Inspection	17
Chapter 6 Function Test	19
6.1 General Information.....	19
6.2 Function Test	19
6.3 Tests from the Ground Controls.....	19
6.4 Test the Emergency Stop Switch	20
6.5 Test the Up/Down Functions	20
6.6 Emergency Lowering Function Test	20



6.7 Platform Controller Test	20
6.8 Horn Test	20
6.9 Lift Function and Function Enable Switch Test	21
6.10 Steering Test	21
6.11 Driving and Braking Function Test	22
6.12 Driving Function Test	22
6.13 Operation of Tilt Sensor Test	22
6.14 Pothole Guard Test	23
Chapter 7 Operating Instructions	25
7.1 General Information	25
7.2 Emergency Stop	25
7.3 Emergency Lowering	25
7.4 Operation from the Ground Controls	25
7.5 Platform Positioning	26
7.6 Operation from the Platform Controls	26
7.7 Platform Positioning	26
7.8 Steering	26
7.9 Drive	26
7.10 Drive Speed Option	27
7.11 Using Platform Controller to Drive the Machine on the Ground	27
7.12 Driving on a Slope	28
7.13 Using the Safety Prop	28
7.14 How to Stow the Guardrail	29
7.15 How to Erect the Guardrail	30
7.16 Extending and Retracting the Extending Platform Deck	30
7.17 Power Supply Switch	30
7.18 Error Codes	32



Chapter 8 Transport and Lifting Instructions	39
8.1 Releasing the Brake.....	39
8.2 Transport Safety	41
8.3 Loading the Machine with a Forklift.....	41
8.4 Lifting Precautions	42
8.5 Parking and Storage	43
Chapter 9 Decals and Warning Labels.....	45
Chapter 10 Specifications	57
10.1 Hydraulic Oil Specifications	70
Chapter 11 Maintenance Schedule.....	71



This page left blank intentionally



Chapter 1 Safety



DANGER

Death or severe injuries can be caused if the instructions and safety regulations in this manual are not followed.



WARNING

Operation of the machine is forbidden, unless:

The safe operation rules of the machine are understood and practiced.

Dangerous conditions are avoided. All safety regulations shall be acknowledged and understood before the next step.

The pre-operation inspection is always completed before operation of the machine.

The function test is always made before operation of the machine.

The workstation is inspected and tested.

The machine is used for its design purposes.

The manufacturer's instruction and safety regulations-the safe operation manuals and machine labels, shall be read, comprehended and followed.

The safety regulations for user and the site regulations shall be read, comprehended and followed.

All applicable laws and regulations of the government are read, understood and followed.

The appropriate training on safe operation of machine has been completed.



NOTICE

Classification of hazards

The meanings of symbols, color codes and characters of LGMG's products are as follows:

Security warning symbol: Are used for warning of potential personal injuries. Observe all safety instructions below these signs, to avoid situations causing potential personal injury and death.



Red: Signifies dangerous situations. If not avoided, will result in personal death or severe injury.



Orange: Signifies dangerous situations. If not avoided, may result in personal death or severe injury.



Yellow: Signifies dangerous situations. If not avoided, may result in minor or



intermediate personal injury.



Blue: Signifies dangerous situations. If not avoided, property loss or damage can occur.

1.1 Description

This machine is a mobile elevating work platform, consisting of a work platform on a scissor mechanism.

1.2 Maintenance of Safety Signs and Decals

Replace any missed or damaged safety signs or decals. If necessary, use mild soap and water to clean safety signs. Do not use solvent-based cleaners because they may damage the safety sign material.

1.3 Workstation Safety



This machine is not electrically insulated and does not provide protection from touching or getting close to electrical power lines. Please keep a safe distance from power lines and power equipment according to the applicable laws and regulations. Refer to the following table for safe approach distances for power lines.

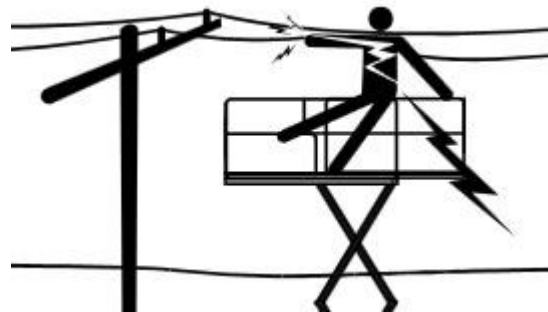

Table 1 Minimum Safe Approach Distance

Voltage	Required Clearance
0 to 50KV	3.05m
50KV to 200KV	4.6m
200KV to 350KV	6.10m
350KV to 500KV	7.62m
500KV to 750KV	10.67m
750KV to 1000KV	13.72m

- Always take into account the influence of strong or gusty winds on the platform and also on the swinging of the electrical power lines.



- Stay away from the machine if it contacts a live electric wire. Do not touch or operate the machine from the ground or the platform before cutting off the power supply.
- Do not operate the machine in inclement weather.
- Do not use the machine as a ground for welding. This could damage electrical components on the machine.
- Do not touch the battery charger when charging the batteries.

Tip Over Hazard

The personnel, equipment, and material on the platform shall not exceed the maximum bearing capacity of the platform and the extending platform. Refer to Chapter 10 – Specifications for model capacities.

- 1) The platform can only be elevated on flat, solid ground.



- 2) The maximum elevated drive speed for machine is 0.8 kph.
- 3) Do not use the tilt alarm as a level indicator. The tilt alarm only sounds when the machine is severely tilted.
- 4) If the tilt alarm sounds: Lower the platform and move the platform to flat, solid ground. If the tilt alarm sounds when elevating the platform, lower the platform immediately.
- 5) If the machine is used outdoors, do not elevate the platform when wind speed is above 12.5 m/s. If wind speed exceeds the limit after elevating the platform, immediately lower the platform and stop all machine operation.
- 6) The ambient temperature range for use of this machine is -20°C to 40°C .
- 7) The relative humidity for use of this machine shall be no greater than 90% (at 20°C).
- 8) The allowable voltage fluctuation of the machine is $\pm 10\%$.
- 9) Do not increase the surface area of platform or load. Increasing the exposure area in wind will reduce the stability of machine.
- 10) When the platform is caught, stuck or blocked by a nearby item and is unable to normally move, do not try to release the platform using the platform controller. All personnel must be removed from the platform before releasing the platform using the ground controller.
- 11) Be cautious and lower drive speed when the machine is fully lowered and driving on an uneven road, a gravel road, an unstable or



smooth surface, near a hole, or on a slope.

- 12) Do not drive in high-speed descending any slope.



Make sure slow speed (turtle) is selected before descending any slope.

- 13) Do not drive the machine on any uneven or unstable roads or in any other dangerous conditions, when the platform is elevated.
- 14) Do not push off or pull toward any object outside of the platform.

Maximum allowable manual force	
Model	Manual Force
S0607E II	Indoor: 400N Outdoor:200N
S0608E II	Indoor: 400N Outdoor:200N
S0808E II	Indoor: 400N Outdoor:200N
S0812E II	Indoor: 400N Outdoor:200N
S1012E II	Indoor: 400N Outdoor:200N
S1212E II	Indoor: 400N Outdoor:200N
S1413E II	Indoor: 400N Outdoor:200N

- 15) Do not use the machine as a crane.
- 16) Do not place, anchor, or suspend any load from any part of the machine.
- 17) Do not push the machine or other items using the platform.
- 18) Do not operate the machine when the chassis tray is pulled out.
- 19) Do not lean the platform against any nearby structure or wall.
- 20) Do not modify or limit the use of the limit switch.
- 21) Do not bind or tie the platform to a nearby

structure or wall.

- 22) Do not place the load outside the platform guard rail.
- 23) Do not modify or change the aerial work platform without the written consent of the manufacturer. Installing an additional device used for carrying tools or other materials on the platform, pedal, or guard rail will increase platform weight, platform surface area, and load.
- 24) Do not modify or damage any safety or stability related parts of the machine.
- 25) Do not replace any key stability-related parts with those with different weights or specifications.
- 26) It is forbidden to use a battery weighing less than the original battery. The battery installed on the chassis is used as counterweight and is vital for the stability of machine. Every battery has a different weight.
- 28) Do not place the steps, ladders, or scaffolding in the platform or lean them against any part of the machine.
- 29) Tools and materials, evenly distributed and able to be safely moved by the operator in the platform, can be carried in the platform only.
- 30) Do not use the machine on a movable surface or vehicle.
- 31) Keep all tires in good condition and appropriately tighten the lug nuts.





 **Crushing Hazards**

- Do not place arms, hands, or fingers in any position where there is a hazard of potential crushing by the machine’s scissors.
- When the machine is being driven from the ground using the controller, use good judgment and carefully plan the travel path. Keep a safe distance between the operator, machine and any fixed objects, walls, or buildings.

 **Hazards**

When Operating on a Slope

Do not drive the machine on a slope that exceeds the slope and side slope rating of the machine. The rated value of slope is applicable to a stowed machine.

Maximum slope rating, stowed position: 	25%(14°)
Maximum side slope rating, stowed position: 	25%(14°)

Note: Slope rating is subject to ground conditions and adequate traction.

 **Falling Hazards**

- All workers in the platform must use approved safety harnesses and attach the lanyard to the provided anchor points in the platform. Each anchor point is limited to one lanyard.



- Do not climb on or sit on the guard rail of the platform. Firmly stand on the platform floor at all times.

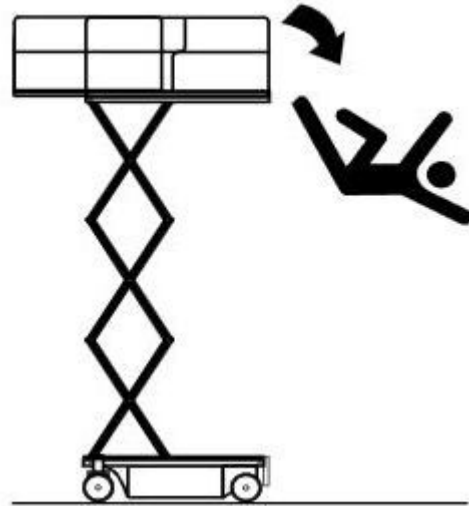

- Do not climb down the platform scissors when the machine is elevated.
- Keep the platform floor free from debris.



- Shut down the platform door before operation.
- Do not operate the machine if the guard rail is not correctly installed.
- Do not enter or exit the platform unless the machine is in the stowed position.

 **Crash Hazards**

- Pay attention to any items or obstacles within the machine's sight line and in any blind spots when starting or running the machine.
- Pay attention to the position of the extending platform when moving the machine.
- Check the workstation to avoid any overhead barriers or other possible hazards in the work site.



- Pay attention to any crushing hazards when holding the guard rail of the platform.
- The operator must follow the

manufacturer's service rules for personal protection equipment, the service rules for the workstation, and the laws and regulations made by the local government.

- Observe and follow the traveling arrow and the turning direction arrows on the platform controller and the platform's label and nameplate.
- Do not operate the machine on the line of any crane or movable overhead machine, unless the crane controller is locked and/or the potential bump prevention measure is taken.
- Dangerous driving or careless operation when running the machine are strictly prohibited.
- The platform can be lowered only when there are no personnel or barriers below the platform.
- Limit travel speed according to ground conditions, traffic, road grade, personnel position, or any other possible bump factors.

 **Component Damage Hazards**

- Do not charge the batteries with anything more than a 24V battery charger.
- Do not use the machine as a ground



for welding. This could cause damage to the electrical components on the machine.

 **Explosion and Fire Hazards**

- Do not operate or charge the machine in a location with a potential for inflammable or explosive gas or particles.

 **Machine Damage Hazards**

- Do not use a damaged or malfunctioning machine.
- Make a complete operational and function check before each shift. Attach an out of service tag on a damaged or malfunctioning machine immediately and stop all operations.
- Be sure to perform all maintenance and operation according to the instructions in this manual.
- Be sure to keep all labels and decals at the appropriate locations. Replace any that are not legible.
- Be sure to keep this manual in the manual box of the platform.

 **Personal Injury Hazards**

- Do not operate the machine if it is leaking hydraulic oil. Leaking hydraulic oil under pressure can

pierce or burn skin.

- It is forbidden to carry out maintenance work when the equipment is electrically charged or the hydraulic system is under pressure.
- Severe injury may result if any component below the cover is touched by mistake. Only trained technicians can perform maintenance to the components under the cover. The operator shall only perform maintenance before the pre-operation inspection. Be sure to keep all compartments closed and locked during operation of the machine.

1.4 Battery Safety

 **Combustion Hazards**

- The battery contains acid. Wear protective clothing and safety goggles when performing maintenance on the battery.
- Take measures to prevent acid from overflowing out of the battery or being touched. Neutralize the overflowed acid material from the battery with soda and water.
- Do not expose the battery or charger to water or rain.



- When cleaning the vehicle, it is forbidden to directly flush and wash the battery, charger and other electrical components.
- Disconnect the main power switch when transporting, repairing or parking the vehicle for a long time.

 **Explosion Danger**

- Keep the battery away from any sparks or open flames. The battery can release an explosive gas.
- Do not touch the battery terminal or the cables with any tool that may cause a spark.

 **Component Damage Hazard**

Do not charge the battery with more than a 24V battery charger.

 **Electrocution/Burn Hazards**

- The battery charger can be connected to the grounded AC three-wire power socket.
- On a daily basis, check to see if the wire cable, electric cable and wiring are damaged. Replace the damaged items before the operation.
- Take measures to prevent electric shock from touching the battery

terminals. When working on the electrical circuits, remove all jewelry and metallic objects. The battery charger can be connected to the grounded AC three-wire power socket.

1.5 Lock After Each Use

- 1) Choose a safe parking position which is solid and horizontal ground where there are no barriers or heavy traffic.
- 2) Lower the platform.
- 3) Rotate the key switch to the "OFF" position and pull out the key, to avoid unauthorized use.
- 4) Charge the battery.



Chapter 2 Machine Nomenclature

 **NOTICE:** This drawing shows an S0808E II , but the nomenclature is common for all other models.

1. Extending Platform
2. Lift Cylinder
3. Scissor Stack Arm
4. Steering Wheel
5. Pothole Protection Device
6. Charging Panel
7. Non-steering Wheel
8. Ladder
9. Safety Prop
10. Main Work Platform
11. Platform Door
12. Guardrail
13. Pedal
14. Platform Control Box

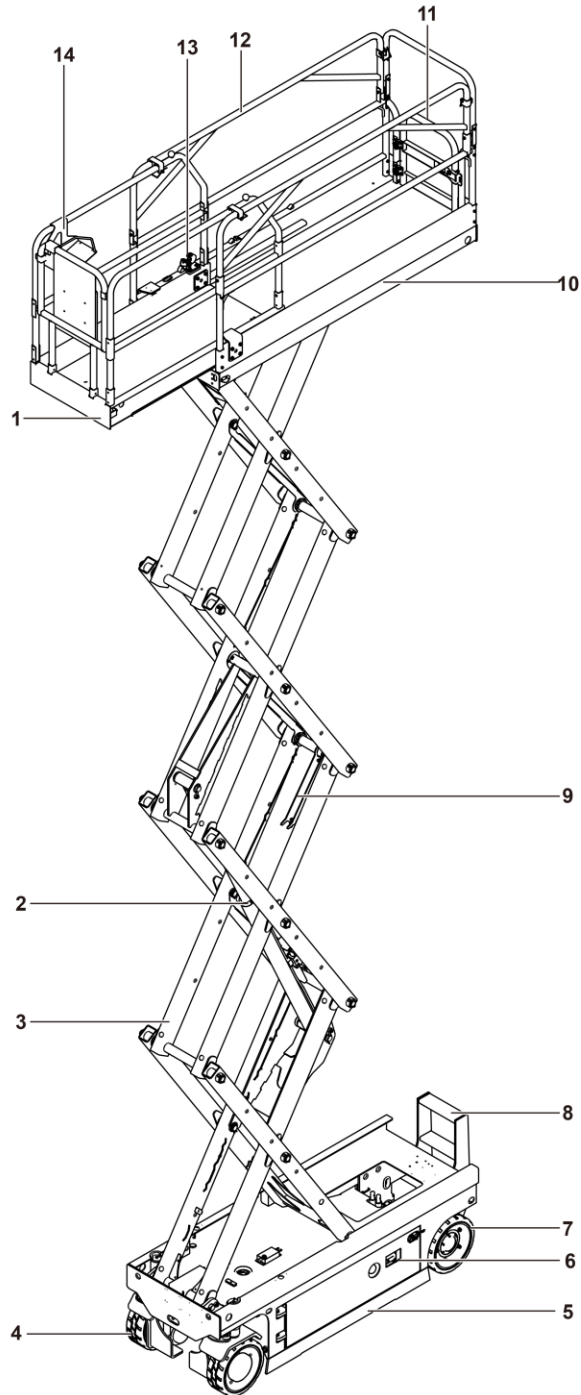



This page left blank intentionally



Chapter 3 Controls

3.1 Ground Controls

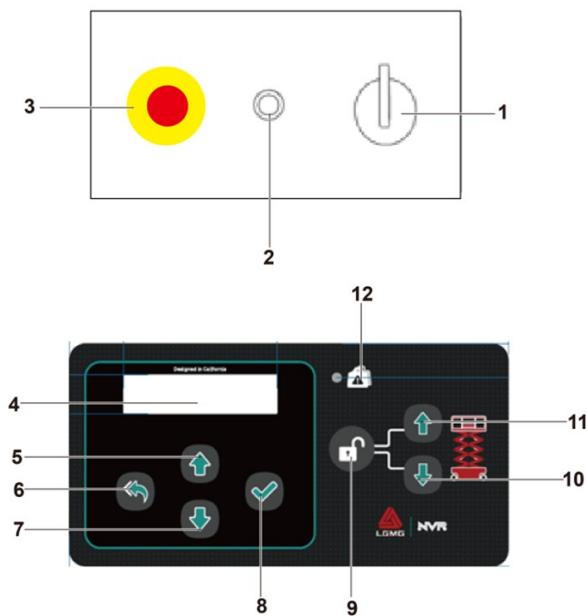

Fig. 3-1 Ground Control

1. Key Switch
2. Auto reset fuse (7A)
3. Emergency stop switch
4. Display
5. Menu up button
6. Menu escape button
7. Menu down button
8. Menu enter button
9. Lift function enable button
Press and hold this button to activate the lift function
10. Platform down button
11. Platform up button
12. Platform overload indicator

3.1.1 Key Switch

The three-position key switch controls the power supply for the machine. When the switch is set to the left, the platform operation mode will be enabled; when the switch is set to the right position, the chassis operation mode will be enabled; when the switch is set to the center position, the power to the machine will be off.



The key can be inserted or removed only when the switch is in the center position. Some machines are equipped with optional switches that allow the keys to be inserted or removed at all three positions.

3.1.2 Emergency Stop Switch

The power supply to the machine is disconnected when the emergency stop switch is pressed.



An emergency stop switch is installed on both the chassis and the platform controller. The two switches operate together in series. Normal operation can be performed when both switches are pulled out. The power supply will be cut off when either emergency stop switch is pressed.



3.2 Platform Controls

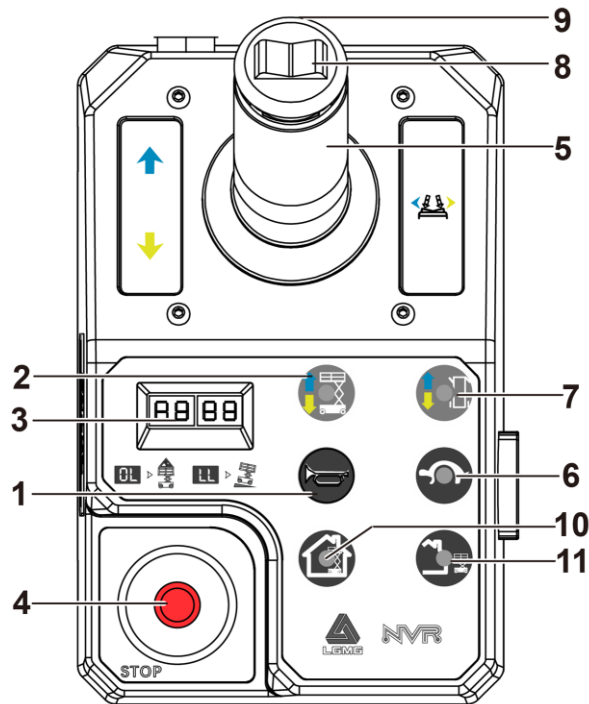

Fig. 3-2 Platform Control

- 1. Horn Button
- 2. Lift function button
- 3. Display
- 4. Emergency Stop Switch
- 5. Control Lever
- 6. Drive Speed Button
- 7. Drive Function Button
- 8. Steer Switch
- 9. Enabling Switch
- 10. Indoor mode button
- 11. Outdoor mode button

3.2.1 Horn Button

The horn will sound when this button is pressed, and will stop when the button is released.

3.2.2 Lift Function Button



Pressing this switch activates the lift function for the platform.

3.2.3 Display

The Display shows Diagnostic Fault Codes and Battery status.

Table 2-Data on the Display

Operating step	Displayed data
Power on but no moving	Battery capacity
Move forward or backward	Battery capacity
Lift up the platform	Battery capacity
Lower the platform	Battery capacity
A fault occurs	Error code
Chassis control mode	C H

3.2.4 Emergency Stop Switch

The power supply to the machine is disconnected when the emergency stop switch is pressed.



An emergency stop switch is installed on both the chassis and the platform controller. The switches operate together in series. Operation can be performed when both switches are pulled out. The power supply will be cut off when either emergency stop switch is pressed.



3.2.5 Drive/Lift Control Lever

Drive function:

After the enabling switch is pressed, the machine will move to the forward when the control lever is moved to the direction (front) indicated by the blue arrow, or to the backward when the control lever is moved to the direction (back) indicated by the yellow arrow.

Lift function:

After the enabling switch is pressed, the platform will raise when the control lever is moved to the forward, or lower when the control lever is moved to the backward.



When the platform is lowering, the lowering alarm will beep.



If using emergency lowering, the alarm will not beep.

3.2.6 Drive Speed Button



Press this button to active the slow drive function. The indicator light will be on when the slow drive is selected.

3.2.7 Drive Function Button



Pressing this button activates the drive function.

3.2.8 Steer Switch



After the drive function button and the enabling switch on the lever are pressed, the steer switch can be used to control the steering direction of the machine.

3.2.9 Enabling Switch

The driving, steering, lifting or lowering function can be activated only when the enabling switch on the lever is pressed.

3.2.10 Indoor mode Button



Applicable models and indoor/outdoor working height:

Model	Maximum working height (m)	
	Indoor	Outdoor
S0808E II	7.8	6



S1212E II	12	7.5
S1413EII	13.8	8

- 1) Press this button, the indicator lamp will light up, and the indoor mode is enabled.
- 2) When the indoor mode is enabled, the lift will be allowed to set to the indoor maximum height.
- 3) At the retracted state, the indoor/outdoor mode can be switched; at the lifting state, the indoor/outdoor mode cannot be switched.
- 4) The default mode is the one when the machine is turned off (Key switch off or emergency stop switch off).

 **WARNING: In case of indoor mode, it is prohibited to move the machine from indoors to outdoors.**

3.2.11 Outdoor mode Button



This function is applied uniformly across the machines equipped with indoor and outdoor lifting height.

- 1) Press this button, the indicator lamp will light up, and the outdoor mode is enabled.

- 2) When the outdoor mode is enabled, the lift will be allowed to set to the outdoor maximum height. Refer to the specifications.
- 3) At the retracted state, the indoor/outdoor mode can be switched; at the lifting state, the indoor/outdoor mode cannot be switched.
- 4) The default mode is the one when the machine is turned off (Key switch off or emergency stop switch off).

 **WARNING: In case of indoor mode, it is prohibited to move the machine from indoors to outdoors.**



Chapter 4 Pre-Operation Inspection



WARNING

Operation of this machine is forbidden, unless the safe operation principles of the machine are understood and practiced.

- All dangerous conditions are avoided.
- The pre-operation inspection is always performed.



NOTICE

Ensure the workstation inspection is fully understood before proceeding to the next step.

- The workstation is inspected and checked.
- The function test is always made before operation.
- The machine is used for its designed purpose.

4.1 Basic Principles

- 1) The pre-operation inspection and routine maintenance are the responsibilities of the operator.

- 2) The pre-operation inspection is a visual process, which shall be performed daily by the operator before each work shift. The purpose of the inspection is to check the machine for any significant problems before performing the Function Test.
- 3) The pre-operation inspection can also be used for confirming if routine maintenance is required. The operator shall only perform routine maintenance as specified in this manual.
- 4) Check the list in the next page and check every item.
- 5) If any damage is found or any un-permitted change different to the delivery status is found, tag the controls and stop operation of the machine.
- 6) Only qualified maintenance technicians are permitted to repair the machine as per LGMG. After the required maintenance has been performed, the operator must carry out the pre-operation inspection again before the function test.

4.2 Pre-Operation Inspection

- 1) Ensure the manual is complete and legible. Keep it in the manual box on the platform.
- 2) Keep all labels clear and readable and place them appropriately. Go through the label.
- 3) Check for any hydraulic oil leakage and proper oil level. Go through the label.



- 4) Check for any battery fluid leakage and if the liquid level is suitable. Add distilled water, if required.
- 5) Inspect the entire machine for:
 - a) Cracks in welds or structural components.
 - b) Machine pitting or damage.
 - c) All structural members and other key components have no missing parts, related fasteners and pins are in the correct position, and properly tightened.
 - d) Install the guard rail, place the guard rail pin in place, and tighten the retaining bolts.
- 6) Check the following components for damage, proper installation, and any missing parts or unauthorized changes to components:
 - a) Battery pack and connections.
 - b) Electric element, wiring and cable.
 - c) Nuts, bolts, and all other fasteners.
 - d) Hydraulic hoses, connectors, cylinders, and valves.
 - e) All Indicator lamps and alarms.
 - f) Safety props.
 - g) Pothole guards.
 - h) Platform overload components (if equipped).
 - i) Scissor arm pins and fasteners.
 - j) Limit switches, alarms, and horn.
 - k) Drive motors.
 - l) Tires and wheels.
 - m) Slide blocks and liners.
 - n) Brake release components.
 - o) Ground straps.
 - p) Platform entry gate.
 - q) Platform control box.
 - r) Extending platform deck.
 - s) Keep the chassis battery tray and oil pump tray closed and locked. Engage the battery disconnect switch.



NOTICE

If the platform must be elevated to inspect any machine components, keep the safety prop in the correct position. Refer to Chapter 7 – Operating Instructions.



Chapter 5 Workstation Inspection



WARNING

Operation is forbidden unless the following safe operating principles of the machine are understood and performed.

- 1) All dangerous work site conditions are avoided.
- 2) Pre-Operation Inspection has been completed.
- 3) The workstation has been inspected.



NOTICE

The workstation inspection must be performed and proper operating procedures understood before the next step.

- 4) The function test has been performed.
- 5) The machine is used as described in this manual.

5.1 General Information

- 1) Using the Workstation Inspection procedures, the operator can determine if the safe operation of machine is possible from the workstation. The operator shall carry out this process before operating the machine from the workstation.

- 2) Understanding the hazards of the workstation are the responsibilities of the operator. Avoid these hazards while moving, delivering, or operating the machine.

5.2 Workstation Inspection

Be aware of the following hazards:

- 1) Sudden slopes, holes, or dips in the traveling surface.
- 2) Bumps, ground barriers, or debris on the ground.
- 3) Inclined plane.
- 4) Infirm or unsteady ground surface.
- 5) Overhead barriers and high-voltage power lines.
- 6) Dangerous location
- 7) Supporting surface unable to bear the load of the machine.
- 8) Wind and inclement weather.
- 9) Unauthorized personnel.
- 10) Other possible unsafe conditions.



This page left blank intentionally



Chapter 6 Function Test



WARNING

Operation is forbidden unless the following safe operating principles of the machine are understood and performed.

- 1) All dangerous work site conditions are avoided.
- 2) Pre-Operation Inspection has been completed.
- 3) The workstation has been inspected.
- 4) The function test has been performed prior to any operation.



NOTICE

The function test must be performed and proper operating procedures understood before the next step.

- 5) The machine is used as described in this manual.

6.1 General Information

- 1) The purpose of the function test is to identify potential component failure before operating the machine.
- 2) The operator must test all machine functions as outlined in this section.

- 3) Do not use a damaged or malfunctioning machine. Tag out the control boxes and do not use the machine until repairs have been made.
- 4) Only qualified maintenance technicians are permitted to repair the machine as per the regulations of the manufacturer.
- 5) After repairs or maintenance have been performed, the operator must perform out the Pre-Operation inspection and functional test again before operating the machine.

6.2 Function Test

- 1) Carry out the function test on a firm and level surface with no barriers or obstructions.
- 2) Ensure the battery pack is connected.

6.3 Tests from the Ground Controls

- 1) Pull out the red emergency stop buttons on the platform controller and the ground controller to the ON position.
- 2) Turn the key switch to the ground controller position.
- 3) Observe the LED display on the platform controller and ground controller for the proper reading.



6.4 Test the Emergency Stop Switch

- 1) Push the emergency stop switch on the ground control station in to the OFF position. Result: All functions should be disabled.
- 2) Pull the emergency stop switch out to the ON position.

6.5 Test the Up/Down Functions



NOTICE

The alarm system will control the buzzer to output the alarms with different frequencies. The lowering alarm will sound 60 times per minute. If the pothole guards fail to deploy and set, the buzzer will sound 180 times per minute. The buzzer will sound 180 times per minute for any overload.

- 1) Position the key switch to the platform controller or the OFF position.
- 2) Press and hold the lift function enabled button, and press the platform up button. Result: The platform fails to elevate.
- 3) Position the key switch to the ground control position.
- 4) Press and hold the lift function enabled button, and press the platform up button. Result: The platform will lift.
- 5) Press and hold the lift function enabled button, and press the platform down button. Result: The platform will lower. When the platform is lowering, the alarm shall sound.

- 6) Press the platform down button again. Result: The platform shall descend to the lowest position. When the platform descends, the alarm shall sound. (If equipped)

6.6 Emergency Lowering Function Test

- 1) Press and hold the lift function enabled button, and press the platform up button to elevate the platform approximately 60cm.
- 2) Pull out the emergency lowering knob at the right front part of the machine. Result: The platform shall descend. The lowering alarm shall not sound.
- 3) Turn the key switch to the platform controller.

6.7 Platform Controller Test

- 1) Push the platform Emergency Stop Switch in to the OFF position. Result: All functions will not operate.
- 2) Pull the Emergency Stop Switch out to the "ON" position. Result: The LED display will light up.

6.8 Horn Test

- 1) Pull the Emergency Stop Switch out to the "ON" position.
- 2) Push the Enable Switch and activate a function.
- 3) Press the horn button. Result: The horn will sound.



6.9 Lift Function and Function Enable Switch Test



- 1) Do not press the enable switch on the control handle.
- 2) Slowly move the control handle forward or backward. Result: All lift functions shall not be operational.
- 3) Press the lift function button.
- 4) Press and hold the enable switch on the control handle.
- 5) Slowly move the control handle forward. Result: The platform shall elevate and the pothole guards shall be deployed.
- 6) Release the platform control handle. Result: The platform will stop elevating.
- 7) Press and hold the enable switch on the control handle. Slowly move the control handle backward. Result: The platform will lower. When the platform lowers, the lowering alarm will sound.

6.10 Steering Test



Face the end of the machine that steers when testing the steering and driving functions.



- 1) Press the drive function button.
The drive function indicator will light.
- 2) Press and hold the enable switch on the control handle.



- 3) Press the rocker switch on top of control handle according to the direction indicated by leftward arrows on the control panel. Result: The machine will turn left.
- 4) Press the rocker switch on top of the control handle according to the direction indicated by rightward arrows on the control panel. Result: The machine will turn right.



6.11 Driving and Braking Function Test



- 1) Press the drive function button.
- 2) Press and hold the enable switch on the control handle.
- 3) Slowly move the control handle in the direction indicated by the blue arrow on the control panel until the machine is moving and return the handle to the center position.
Result: The machine shall move forward and then stop.
- 4) Slowly move the control handle in the direction indicated by the yellow arrow on the control panel until the machine is moving and return the handle to the center position.
Result: The machine shall move backward and then stop.



The brake must be able to hold the machine on any grade it is able to climb.

6.12 Driving Function Test

- 1) Raise the platform to a certain height.

Result: The pothole guards will be deployed.

- 2) Press the drive function button. The indicator light will light up.
- 3) Press and hold the enable switch on the control handle and slowly move the control handle fully forward.

Result: The drive speed of the platform will not be greater than 0.8km/h when the platform is elevated. If the elevated driving speed of the platform exceeds these limits, immediately tag out the controls and stop operation until repairs are made.

6.13 Operation of Tilt Sensor Test



This test is performed with the platform controller from the ground. Do not stand in the platform.

- 1) Completely lower the platform.
- 2) Drive the machine to the slope that just exceeds the maximum allowable tilt angle of the machine.
- 3) Raise the platform to a certain height.

Result: The platform will stop moving and the tilt alarm will sound.

- 4) Slowly move the control handle to operate drive forward and then driver reverse. Result:



The drive function will be disabled in either direction.

5) Lower the platform and drive the machine off of the slope.

6) Lower the platform and remove the blocks.

6.14 Pothole Guard Test



NOTICE:

When the platform is elevated, the pothole guards will be automatically deployed. The pothole guards initialize another limit switch to enable the continuous drive/steer operation of machine. If the pothole guards fails to be deployed, the alarm will sound and the machine will stop all drive and steer functions.

- 1) Raise the platform to a certain height.
- 2) Result: The pothole guards shall be deployed.
- 3) Press one side of the pothole guard and then other side. Result: The pothole guard will not move.
- 4) Lower the platform. Result: The pothole guard will be returned to the stowed position.
- 5) Place blocks under the pothole guards 3.5cm×20cm wood block or a similar material and elevate the platform.

Result: The alarm will sound. The drive function will be disabled.





Chapter 7 Operating Instructions



WARNING:

Operation is forbidden unless the following safe operating principles of the machine are understood and performed.

- 1) The dangerous conditions are avoided.
- 2) The pre-operation inspection is always made.
- 3) The workstation is checked.
- 4) The function test is always made before the use.
- 5) The machine is used for its design purposes.

7.1 General Information

- 1) This machine is a mobile elevating work platform, consisting of a work platform on an elevating scissors mechanism. The vibration produced by the running machine causes no hazards to the operators on the work platform. This machine can be used for carrying the workers and their tools to the specified height above the ground and also for reaching the workstation above the machine or equipment.
- 2) Detailed operating instructions for all functions are outlined in this Operation section. It is the operator's responsibility to follow all safety regulations and descriptions in this operation and maintenance manual.
- 3) It is prohibited to use the machine for any

purpose other than carrying the staff, equipment, tool and material to the overhead workstation.

- 4) Only trained and authorized personnel can operate this machine. Each operator shall perform the pre-operation inspection, function test and workstation inspection before running the machine.

7.2 Emergency Stop

- 1) Push the emergency stop switch on the ground or platform controller to the OFF position to disable all functions.
- 2) Repair any function that operates when either emergency stop switch is pushed in.

7.3 Emergency Lowering



Emergency lowering knob

Pull the emergency lowering knob outward to lower the platform.

7.4 Operation from the Ground Controls

- 1) Turn the key switch to the ground position.



- 2) Pull the emergency stop switch on the ground and the platform to the ON position.
- 3) Ensure the battery tray is connected before running the machine.

7.5 Platform Positioning

- 1) Press and hold the lift function enable button.
- 2) Press the platform up/down button.
- 3) The driving and turning functions are unavailable from the ground controller.

7.6 Operation from the Platform Controls

- 1) Turn the key switch to the platform control position.
- 2) Pull the emergency stop switch out on both ground controls and the platform controls to the ON position.
- 3) Ensure the battery tray is connected before running the machine.

7.7 Platform Positioning

- 1) Press the lift function button.
- 2) Press and hold the enable switch on the control handle.
- 3) The platform will rise when the control lever is moved to the forward, or lower when the control lever is moved to the backward.

7.8 Steering

- 1) Press the drive function button.
- 2) Press and hold the enable switch on the control handle.

- 3) Turn the wheels in the desired direction using the rocker switch on the top of control handle.

7.9 Drive

- 1) Press the drive function button.
- 2) Press and hold the enable switch on the control handle.
- 3) To increase speed: Slowly move the control handle away from the centered position. To decrease speed: Slowly return the control handle to the center position. To stop: Fully return the handle to the center position or release the enable switch.
- 4) Coordinate machine drive direction with the direction arrows on the platform controller and the platform.
- 5) When the platform is elevated, the drive speed of the machine is reduced.
- 6) The status of the battery pack will affect machine performance.
- 7) When the battery level indicator lamp flashes, driving speed and functional speed of machine will be reduced.









7.10 Drive Speed Option

The drive controller can be operated at two different drive speeds. When the drive speed selector switch indicator lights up, slow driving speed mode is enabled. When the driving speed selector switch lamp goes out, the high speed drive mode is enabled. Press the driving speed selector switch to select the desired driving speed.

7.11 Using Platform Controller to Drive the Machine on the Ground

- 1) Keep a safe distance between the operator, machine, and any stationary object.
- 2) Be cautious and aware of the driving direction of machine when using the controller from the ground.
- 3) Identify the battery level with the LED display.

Table 3 - Battery Level as Shown on LED Display

Platform Display	Battery Percentage (%)	Description
	90-100	The battery capacity is full
	70	Percentage of remaining battery capacity
	50	Percentage of remaining battery capacity
	30	Percentage of remaining battery capacity
	20	The battery must be charged
	10	The battery capacity is very low





NOTICE

When the battery capacity is very low ($\leq 10\%$), the machine will change to low speed mode automatically.



7.12 Driving on a Slope

Determine the slope and side slope ratings for the machine and determine the slope grade.

<p>Maximum slope rating, stowed position:</p> 	<p>25%(14°)</p>
<p>Maximum side slope rating, stowed position:</p> 	<p>25%(14°)</p>

Note: Slope rating is subject to ground conditions with one person in the platform and adequate traction. Additional platform weight may reduce slope rating.

Measure the slope by using a digital inclinometer or as per the following steps.

- ✓ Required tools: Carpenters rule, straight wood block (with length of at least 1m), tape measure and other tools.
- ✓ Place the wood block on the slope, place the carpenters rule on the upper limb of the wood block at the end of down-slope, and lift the end of the wood block until it is horizontal.
- ✓ Keep the wood block in the horizontal state, and measure vertical height from the bottom of the wood block to the ground.
- ✓ Height is divided by the length of wood block (stroke), i.e.,

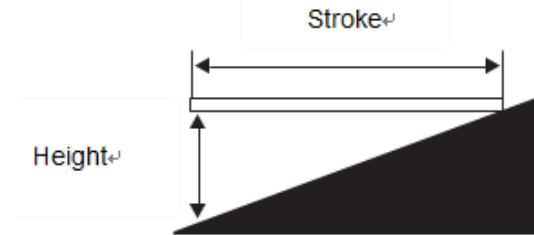

Stroke=3.6m

lifting height=0.3m

$$0.3 \div 3.6 = 0.083 = 8.3\%$$

If the slope exceeds the maximum uphill, downhill or side slope rating, the vehicle must be winched or transported up or down the slope.

7.13 Using the Safety Prop

- 1) Raise the platform to a certain height.
- 2) Lift the safety prop, move it to the center of the scissor cross tube and rotate it upward until it is vertical.
- 3) Lower the platform height until the safety prop completely contacts the shaft tube. Keep the platform away from the movable parts during the lowering process.



Do not carry any load in the platform when the safety prop is being used. No long time (8 hours) to use safety prop in empty state.



7.14 How to Stow the

Guardrail

On model S0607E II , the platform guardrail system consists of a folding guardrail on an extended platform and a folding guardrail on the main platform.

- 1) Fully lower the platform and lock it into the extended platform.
- 2) Remove the platform controller.
- 3) Remove the M-shaped fixed seat between the guardrails of the main platform and the extended platform from the inside of the platform and place it in the platform.
- 4) Remove the fixing bolt from the tube of the extended platform guardrail, press the guardrail carefully, install the fixing bolt.
- 5) Remove the fixing bolt from the tube of the main platform guardrail, press the guardrail carefully, install the fixing bolt.

On model S0808E II , the platform guardrail system consists of a folding guardrail on an extended platform and a folding guardrail on the main platform.

- 1) Fully lower the platform and lock it into the extended platform.
- 2) Remove the platform controller.
- 3) Remove the M-shaped fixed seat between the guardrails of the main platform and the extended platform from the inside of the platform and place it in the platform.
- 4) Remove the retaining pins at the front of the extended platform from the inside of the main platform.
- 5) Fold the front guardrail of the extended

platform inward. Do not place your hands in places where there may be a pinch point. At the same time, prevent the left and right guardrails of the extended platform from tilting over.

- 6) Install the retaining pins which were removed back to the guardrail on each side.
- 7) Fold the left guardrail of the extending platform inward. Do not place your hands in places where there may be a pinch point. At the same time, prevent the right guardrails of the extended platform from tilting over.
- 8) Fold the right guardrail of the extending platform inward. Do not place your hands in places where there may be a pinch point.
- 9) Remove the two retaining pins on the upper part of the door.
- 10) Fold the left guardrail of main platform from the ladder or the ground inward. Do not place your hands in places where there may be a pinch point. At the same time, prevent the right guardrails of the main platform from tilting over.
- 11) Fold the right guardrail of main platform from the ladder or the ground inward. Do not place your hands in places where there may be a pinch point.
- 12) Fold the door guardrail from the ladder or the ground inward. Do not place your hands in places where there may be a pinch point.
- 13) Install the retaining pins which were removed back to the guardrail on each side.

On models S0812E II /S1012E II /S1212E II / S1413E II , the platform guardrail system consists of a folding guardrail on an extended platform and a folding guardrail on the main



platform.

- 1) Fully lower the platform and lock it into the extended platform.
- 2) Remove the platform controller.
- 3) Remove the M-shaped fixed seat between the guardrails of the main platform and the extended platform from the inside of the platform and place it in the platform.
- 4) Remove the retaining pins at the front of the extended platform from the inside of the main platform.
- 5) Fold the front guardrail of the extended platform inward. Do not place your hands in places where there may be a pinch point. At the same time, prevent the left and right guardrails of the extended platform from tilting over.
- 6) Install the retaining pins which were removed back to the guardrail on each side.
- 7) Fold the left guardrail of the extending platform inward. Do not place your hands in places where there may be a pinch point. At the same time, prevent the right guardrails of the extended platform from tilting over.
- 8) Fold the right guardrail of the extending platform inward. Do not place your hands in places where there may be a pinch point.
- 9) Remove the retaining pins on the upper part of the door.
- 10) Fold the door guardrail from the ladder or the ground inward. Do not place your hands in places where there may be a pinch point. At the same time, prevent the left and right guardrails of the extended platform from tilting over.
- 11) Rotate the semi-revolving door until the right

and left guardrails can be folded smoothly, from the ladder or the ground inward. Do not place your hands in places where there may be a pinch point. At the same time, prevent the guardrails of the main platform from tilting over.

- 12) Install the retaining pins which were removed back to the guardrail on each side.

7.15 How to Erect the Guardrail

To erect the guardrails, reverse the sequence outlined in How to Stow the Guardrail.

7.16 Extending and Retracting the Extending Platform Deck

- 1) Step on the positioning pedal on the extending platform.
- 2) Push the guardrail of the extending platform to extend the platform to the desired position.



NOTICE

Do not stand on the extending platform deck while extending it.

7.17 Power Supply Switch

1. DC power switch (If equipped)

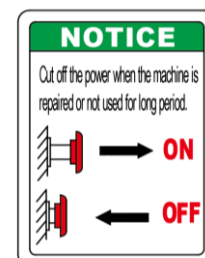



Press the DC power switch, power supply of the whole machine will be disconnected.

Pull out the DC power switch and power supply of the whole machine will be connected.



NOTICE:

Disconnect the main power switch when the machine is in transportation/ repaired or not used for a long time.



7.18 Error Codes



When an error code is present, the code will flash once per second on the screens of the ECU and PCU.

Table 4 - Error Codes

Display	Description	Response
01	System initialization error	Stop all actions
02	System communication error	Stop all actions
03	Model error	Stop all actions
05	ECU and BMS communication failure	Lifting and travelling are prohibited.
09	Invalid pedal alarm	Stop lifting and running
10	The alarm switch is on when height limit rod is being touched	Stop lifting and running
11	Upper&Lower limit abnormality	Display alarm only
12	Chassis lifting or lowering button opening error during start	Stop all chassis controls
14	Motor controller 1 communication failure	Stop lifting and running
15	Motor controller 2 communication failure	Stop lifting and running
16	BMS fault	Stop lifting and running
18	Pothole protection error	Stop lifting and running
23	Traveling function is limited when lifting	Stop running
27	Down proportional valve fault	Stop lifting and running
31	Pressure sensor error	Stop lifting and running
32	Angle sensor error	Stop lifting and running
33	No calibration of light load	Stop lifting
34	Down after overload	Display alarm only
35	Load calibration error	Display alarm only
36	Low battery alarm	Speed reduced to low speed
38	Load calibration error	Stop lifting



Operation Manual of Scissors Mobile Elevating Work Platform

40	GPS communication failure	Display alarm only
41	GPS level 1 lockout	Stop lifting
42	Platform left turn button pressing error during start	Display alarm only
43	Platform right turn button pressing error during start	Display alarm only
44	ZAPI 1 fault (AC pump motor parameter fault)	Display alarm only
45	ZAPI 2 fault (AC pump motor hardware fault)	Display alarm only
46	Platform handle enable switch button pressing error during start	Stop platform control
47	"The platform handle is not in the middle position" error during start	Display alarm only
49	AC pump motor: Motor fault detected	Display alarm only
50	AC pump motor connector fault	Display alarm only
51	Wireless collision avoidance alarm	Stop lifting
52	Forward coil error	Stop lifting and running
53	Backward coil error	Stop lifting and running
54	Lifting error of lifting coil	Stop lifting and running
55	Lifting error of lowering coil	Stop lifting and running
56	Right turn coil error	Stop lifting and running
57	Left turn coil error	Stop lifting and running
58	Brake coil error	Stop lifting and running
60	Motor controller fault	Stop lifting and running
61	Motor controller current sensor fault	Display alarm only
62	Motor controller damaged hardware fault	Display alarm only
63	Motor controller output fault	Display alarm only
64	Motor controller SRO fault	Display alarm only
67	Motor controller HPD fault	Display alarm only
68	Low voltage fault	Lifting and high speed running are prohibited
69	Motor controller	Stop lifting and running
70	Motor controller	Stop lifting and running
71	Motor controller contactor fault	Stop lifting and running
73	Motor controller overheated	Display alarm only
74	Motor controller fault	Display alarm only



Operation Manual of Scissors Mobile Elevating Work Platform

75	Motor controller pump motor fault	Stop lifting and running
76	Motor controller left drive motor fault	Stop lifting and running
77	Motor controller right drive motor fault	Stop lifting and running
78	Motor controller pump motor short-circuit fault	Stop lifting and running
79	Left drive motor short-circuit fault	Stop lifting and running
80	Alarm of exceeding 80% load	Alarm only
81	Right drive motor short-circuit fault	Stop lifting and running
82	Left brake coil fault	Stop lifting and running
83	Right brake coil fault	Stop lifting and running
84	Motor POST Short Fault	Stop lifting and running
89	Motor excitation open-circuit fault	Stop lifting and running
90	Alarm of exceeding 90% load	Alarm only
91	Motor excitation short-circuit error	Stop lifting and running
92	Motor excitation short-circuit error	Stop lifting and running
93	AC pump brake fault	Display alarm only
94	AC pump drive temperature fault	Display alarm only
95	AC pump motor temperature fault	Display alarm only
96	AC pump abnormal voltage/ electric quantity	Display alarm only
97	AC pump CANBUS communication fault	Display alarm only
98	AC pump speed sensor fault	Display alarm only
99	Alarm of exceeding 99% load	Alarm only
100-114	Three-phase AC motor drive node 8 fault (100-144)	Display alarm only
115-128	Three-phase AC motor drive node 9 fault (115-128)	Display alarm only
129-142	Three-phase AC motor drive node A fault (129-142)	Display alarm only
OL	Platform overload alarm	Stop all actions
LL	"The machine tilts over the safety limit" error	Stop lifting and running



Table 5 - Troubleshooting Guide

Display	Description
01	Restart device or replace ECU
02	System communication error: Check connection between the communication line and other cables. If fault still exists, please replace the PCU or the ECU
03	Invalid option setting error: Set proper options for the machine
05	Check if CAN bus are contacted well or have lithium battery replaced
09	Release the pedal switch, if it is invalid, check the connection status of pedal harness (check for short-circuit)
10	Down alarm override
11	Reset upper limit switch or outdoor limit switch
12	Check if the chassis lifting or descending button is pressed when powered on, or replace ECU
14	Check if CAN bus are contacted well or have electric drive type modified
15	Check if CAN bus are contacted well or have electric drive type modified
16	Check if CAN bus are contacted well or have lithium battery replaced
18	Pothole protection error: Check whether the pothole protection is activated, and check the pothole protection limit switch. Check the wiring of the switch, lower limit switch and wiring.
23	Down alarm override
27	Check or replace the down proportional valve
31	Pressure sensor error: Check the sensor wiring and the sensor. Check to confirm that the correct machine option with overload detection is selected
32	Angle sensor error: Check the sensor wiring and the sensor. Check to confirm that the correct machine option with overload detection is selected
33	Calibrate light load, or shut off double load function
34	This fault is only apply to warn the operator
35	Recalibrate no load and full load
36	When the battery power is low, charge it in time; If the battery power is normal, check the wiring or replace the ECU,
38	Recalibration
40	Check if CAN bus are contacted well or have GPS device replaced
41	Unlock or contact GPS device
42	Platform left turn button pressing error during start: Ensure that buttons on the handle are not pressed. If not, consider replacing the handle or the PCU
43	Platform right turn button pressing error during start: Ensure that buttons on the handle are not pressed. If not, consider replacing the handle or the PCU
44	Replace the motor driver or contact the motor manufacturer
45	Replace the motor driver or contact the motor manufacturer
46	Platform handle enable switch button pressing error during start: Ensure that the enable switch on the handle is not pressed. If not, consider replacing the handle or the PCU



Operation Manual of Scissors Mobile Elevating Work Platform

Display	Description
47	"The platform handle is not in the middle position" error during start: Confirm that the handle is in the middle position, and check the middle position parameter setting. If normal, consider replacing the handle or the PCU
49	Replace the motor driver or contact the manufacturer
50	Replace the motor driver or contact the manufacturer
51	Down alarm override
52	Forward coil error: Check the connection of the coil and confirm that it is normal. If normal, check the coil for short circuit or open circuit
53	Backward coil error: Check the connection of the coil and confirm that it is normal. If normal, check the coil for short circuit or open circuit
54	Lifting error of lifting coil: Check the connection of the coil and confirm that it is normal. If normal, check the coil for short circuit or open circuit
55	Lifting error of lowering coil: Check the connection of the coil and confirm that it is normal. If normal, check the coil for short circuit or open circuit
56	Right turn coil error: Check the connection of the coil and confirm that it is normal. If normal, check the coil for short circuit or open circuit.
57	Left turn coil error: Check the connection of the coil and confirm that it is normal. If normal, check the coil for short circuit or open circuit.
58	Brake coil error: Check the connection of the coil and confirm that it is normal. If normal, check the coil for short circuit or open circuit.
60	Replace the motor driver or contact the manufacturer
61	Replace the motor driver or contact the manufacturer
62	Replace the motor driver or contact the manufacturer
63	Replace the motor driver or contact the manufacturer
64	Replace the motor driver or contact the manufacturer
67	Replace the motor driver or contact the manufacturer
68	Charge in time; when battery is working well , check the cable or replace the ECU
69	Replace the motor driver or contact the manufacturer
70	Replace the motor driver or contact the manufacturer
71	Replace the motor driver or contact the manufacturer
73	Replace the motor driver or contact the manufacturer
74	Replace the motor driver or contact the manufacturer
75	Replace the motor driver or contact the manufacturer
76	Replace the motor driver or contact the manufacturer



Operation Manual of Scissors Mobile Elevating Work Platform

Display	Description
77	Replace the motor driver or contact the manufacturer
78	Replace the motor driver or contact the manufacturer
79	Replace the motor driver or contact the manufacturer
80	Alarm of exceeding 80% load: As the platform is close to the load limit, it is not recommended to increase the load
81	Replace the motor driver or contact the manufacturer
82	Check the connection of the coil and confirm that it is normal. If normal, check the coil for short circuit or open circuit.
83	Check the connection of the coil and confirm that it is normal. If normal, check the coil for short circuit or open circuit.
84	Replace the motor driver or contact the manufacturer
89	Replace the motor driver or contact the manufacturer
90	Alarm of exceeding 90% load: As the platform is close to the load limit, it is not recommended to increase the load
91	Replace the motor driver or contact the manufacturer
92	Replace the motor driver or contact the manufacturer
93	Replace the motor driver or contact the manufacturer
94	Replace the motor driver or contact the manufacturer
95	Replace the motor driver or contact the manufacturer
96	Replace the motor driver or contact the manufacturer
97	Replace the motor driver or contact the manufacturer
98	Replace the motor driver or contact the manufacturer
99	Alarm of exceeding 99% load: As the platform has reached the load limit, do not to increase the load
100-114	Replace the motor driver or contact the manufacturer
115-128	Replace the motor driver or contact the manufacturer
129-142	Replace the motor driver or contact the manufacturer
OL	Platform overload alarm: Remove excessive loads immediately
LL	If the machine is tilted, try to restore it to horizontal level, and if not tilted, it needs to check the level sensor wiring and the sensor itself and recalibrate.



This page left blank intentionally



Chapter 8 Transport and Lifting Instructions



WARNING

Obey these instructions.

- When lifting the machine with a crane, ensure the crane has the proper capacity and rigging to handle the weight of the machine.
- Only qualified personnel are allowed to load and unload the machine onto a truck for transport.
- The hauling vehicle must be parked on firm, level ground.
- When loading the machine, be sure to chock the wheels of the hauling vehicle to ensure it won't move.
- Ensure vehicle capacity, load surface, and tie down equipment is adequate for bearing the weight of the machine. Refer to the nameplate on the machine for gross weight.
- Be sure to load the machine on a flat, level surface and chock the wheels before releasing the brake.
- Do not drive the machine when traveling up and down a slope or when driving on a slope exceeding the rated gradeability for the machine. For driving on a slope, refer to Chapter 7 – Operating Instructions. If the loading ramp of the hauling vehicle exceeds the maximum rated travel grade of the machine, load and unload the machine with a

winch as per the instruction for brake releasing operation.

8.1 Releasing the Brake



Collision Hazard

Failure to secure machine before releasing brakes will result in death or serious injury.

1. Make sure machine is on a firm, level surface or secured.
2. Chock wheels.
3. Release brakes.

Brake Release Operation (For electric drive models)



NOTICE:

Before release the brake, the main power supply should be connected, and the emergency stop switch on the chassis and platform must be cut off.

1. Chock wheels to prevent machine from rolling.
2. Be sure winch line is properly secured to drive chassis tie points and path is clear of all obstructions.
3. Turn the key switch to the right side to release the brake.

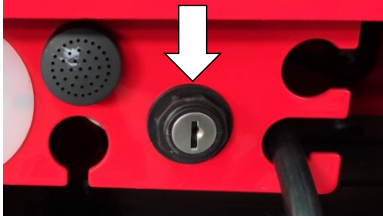

After brake release operation:

1. Chock wheels to prevent machine from rolling.
2. Turn the key switch to the off position to engage the brake.
3. If system voltage is lower than 16.8v, operate the drive motor according to the following procedure.

① Unscrew the drive motor end cover;



② Screw the M6*25 bolt into the screw holes in the brake disc, see Figure2 ;



③ Turn the bolt clockwise. When the brake clearance is greater than 0.003in (0.08 mm), the brake is released.



④ Repeat the above procedure on opposite drive motor. With both drive motor brake released the machine can be moved manually.

⑤ After moving the machine, reinstall both drive motors to the original conditions.



8.2 Transport Safety

- 1) Chock the machine wheels when preparing for transport.
- 2) Retract and secure the extending platform.
- 3) Switch the key switch to the OFF position and take out the key before transporting the machine. Disconnect and remove the platform control box. Store in a safe location prior to transporting the machine.
- 4) Ensure the front and rear wheels are securely chocked and the machine is inspected to ensure there are no loose or unsecured parts.
- 5) Secure the machine on the transport surface using the tie down areas on the chassis.

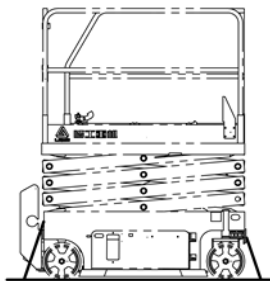

- 6) Use at least four chains or tie straps.

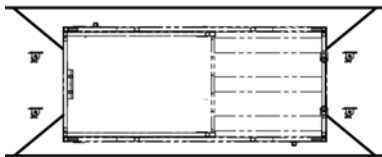

- 7) Be sure to use chains or tie straps of sufficient load capacity.
- 8) Secure the folded guard rail (if any) with a tie

strap before transport



WARNING

Obey the following instructions.

- Only personnel qualified in loading and transporting heavy equipment can rig lifting equipment and lift the machine.

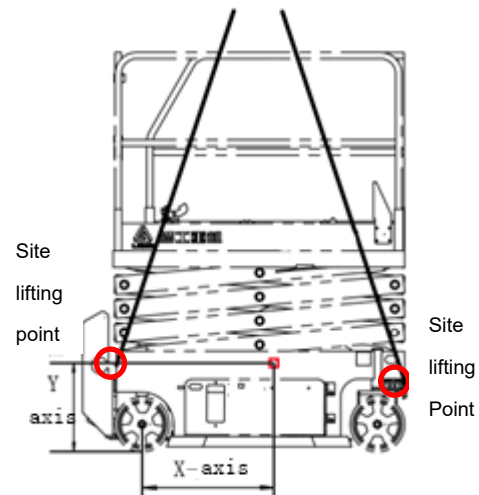

- Only personnel qualified in forklift operation qualification are permitted to load and unload the machine with a forklift.
- Ensure that the lifting capacity, loading surface, loading straps, or rope of the crane is sufficient to bear the machine weight. For serial number, please refer to the nameplate.

8.3 Loading the Machine with a Forklift

- 1) Be sure to secure the extending platform, the controller and the chassis tray. Remove all movable components from the machine.
- 2) Completely lower the platform. Keep the



platform folded in each transport process.

- 3) Use the forklift pockets on both sides of the ladder.

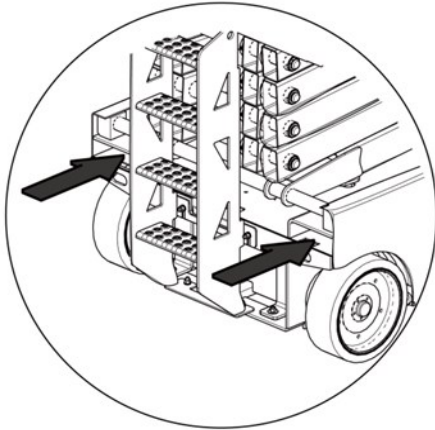

- 4) Place the forks of the forklift into the forklift pockets.
- 5) Drive the forklift forward to completely insert the fork into the pockets.
- 6) Lift the machine by 40cm and slightly tilt the fork backward to keep the machine stable.
- 7) Keep the machine level when lowering the fork.



Component damage may result from the machine being lifted from its' side.

8.4 Lifting Precautions

- 1) Completely lower the platform. Be sure to secure the extending platform, the controller and the chassis tray. Remove all movable components from the machine.



Use the center of gravity shown on the lifting decal on the machine.

- 2) The spreader can only be attached to the specified lifting point on the machine shown.
- 3) There are two lifting holes in the front panel of the machine, and there are two lifting holes in the rear end board to use for lifting the machine.
- 4) Adjust the lock tool in such a way that the machine is not damaged and the machine is kept horizontal.



8.5 Parking and Storage

Follow the parking and storage instructions below:

- 1) Drive the machine to a well-protected and well-ventilated area.
- 2) Be sure to completely lower the platform.
- 3) Push the emergency stop switch in to the OFF position.
- 4) If necessary, cover the control panel and the warning signs to protect them against the environment.
- 5) If the machine is parked for a long period, cover the wheels on both sides with a blocking board.
- 6) Turn the power supply selector switch to the OFF position and pull out the key to avoid starting and unauthorized use of equipment.
- 7) If equipped with the optional anti-vandalism package, the working station and ground control box can be covered and locked to prevent vandalism.



This page left blank intentionally



Chapter 9 Decals and Warning Labels

S0607E II Decal Diagram

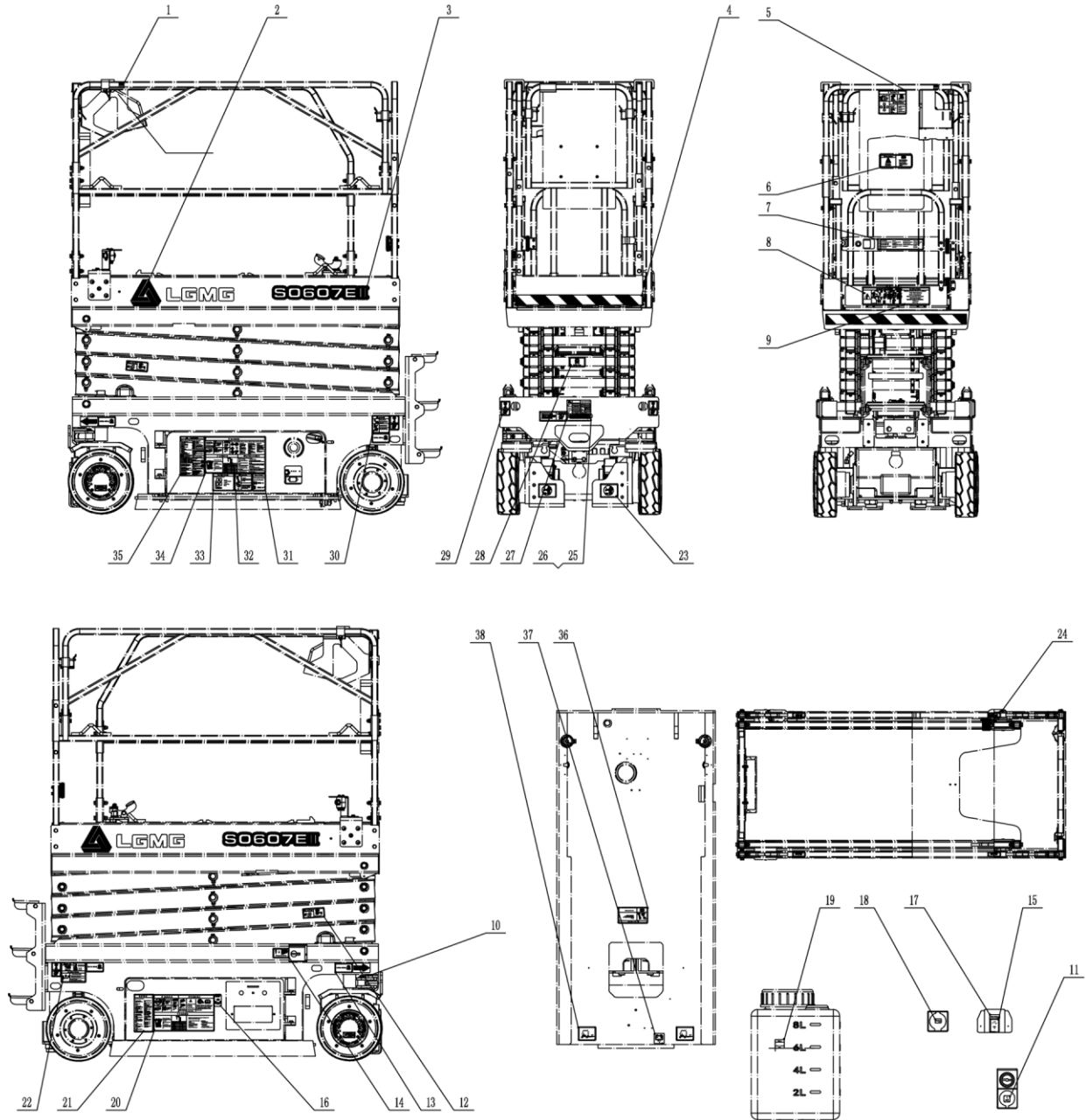



















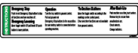
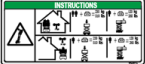



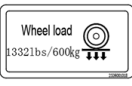

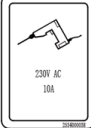
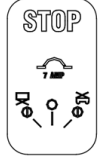



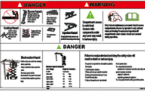





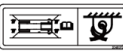

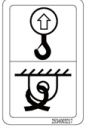
S0607E II Decal List

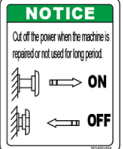
Item	Description	Item	Description
1	Hanger	20	Decal-Oil level
2	Decal-Group LOGO	21	Decal-Oil tank side
3	Decal-Model	22	Note Description Identification
4	Decal-Warning line	23	Decal-Warning, Brake release safety
5	Decal-Front guardrail	24	Decal-Lanyard anchorage point
6	Decal-Operation manual	25	Decal-Lanyard fixed point
7	Decal-Operation Instruction	26	Decal-Machine nameplate
8	Decal-Warning, Platform safety	27	Bolt
9	Decal-Maximum hand power	28	Decal-Transport tiedown
10	Direction of advance identification	29	Fork safety arm
11	Decal-Warning, Platform power	30	Decal-Lifting
12	Decal-Stay away from machine	31	Decal-Warning, Electric shock&fire
13	Decal-Wheel load	32	Decal-Turn off power
14	Decal-Emergency lowering	33	Decal-Battery as counterweight
15	Decal-Rated voltage	34	Decal-Warning, Battery connection
16	Decal-Ground control panel	35	Decal-Battery side
17	Decal-Platform power	36	Decal-Safe rules description
18	Decal-Charging	37	Decal-Tilting risk
19	Hanger	38	Decal-Battery charging

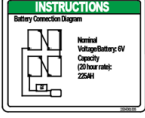

Operation Manual of Scissors Mobile Elevating Work Platform

S0607E II Decals

1-2534000975  Platform Controls Location 2534000975	2-2534000218  LGMG	3-25340003158  S0607EII	4-2534000024 	5-2534003214  DANGER INSTRUCTIONS	6-2534000986  WARNING
7-2534000997 	8-2534001114  INSTRUCTIONS	9-2534001106  INSTRUCTIONS	10-2534000102 	11-2534001803  230V 2534001803	12-2534000973  DANGER Charging
13-2534001018  Wheel load 13321lbs/600kg	14-2534000981  Emergency Lowering	15-2534000038  230V AC 10A	16-2534000808  STOP	17-2534003297  Platform AC power	18-2534003298  Charging
19-2534000100  Max Min	20-2534003213 	21-2534000983  NOTICE	22-2534001732  DANGER INSTRUCTIONS	23-2534000124 	24-2534000017 
25/26-2534003675 	27-2534001972 	28-2534000992  Safety Arm	29-2534003217 	30-2534000976  DANGER Electrostatic Discharge Hazard	31-2534001056  NOTICE Cut off the power when the machine is repaired or not used for long period.
32-2534000989  DANGER	33-2534001005  INSTRUCTIONS Battery Connection Diagram	34-2534003212  DANGER	35-2534000984  DANGER	36-2534000987  DANGER	37-2534002033  230V AC 10A
38-2534000101 					



S0808E II Decal Diagram

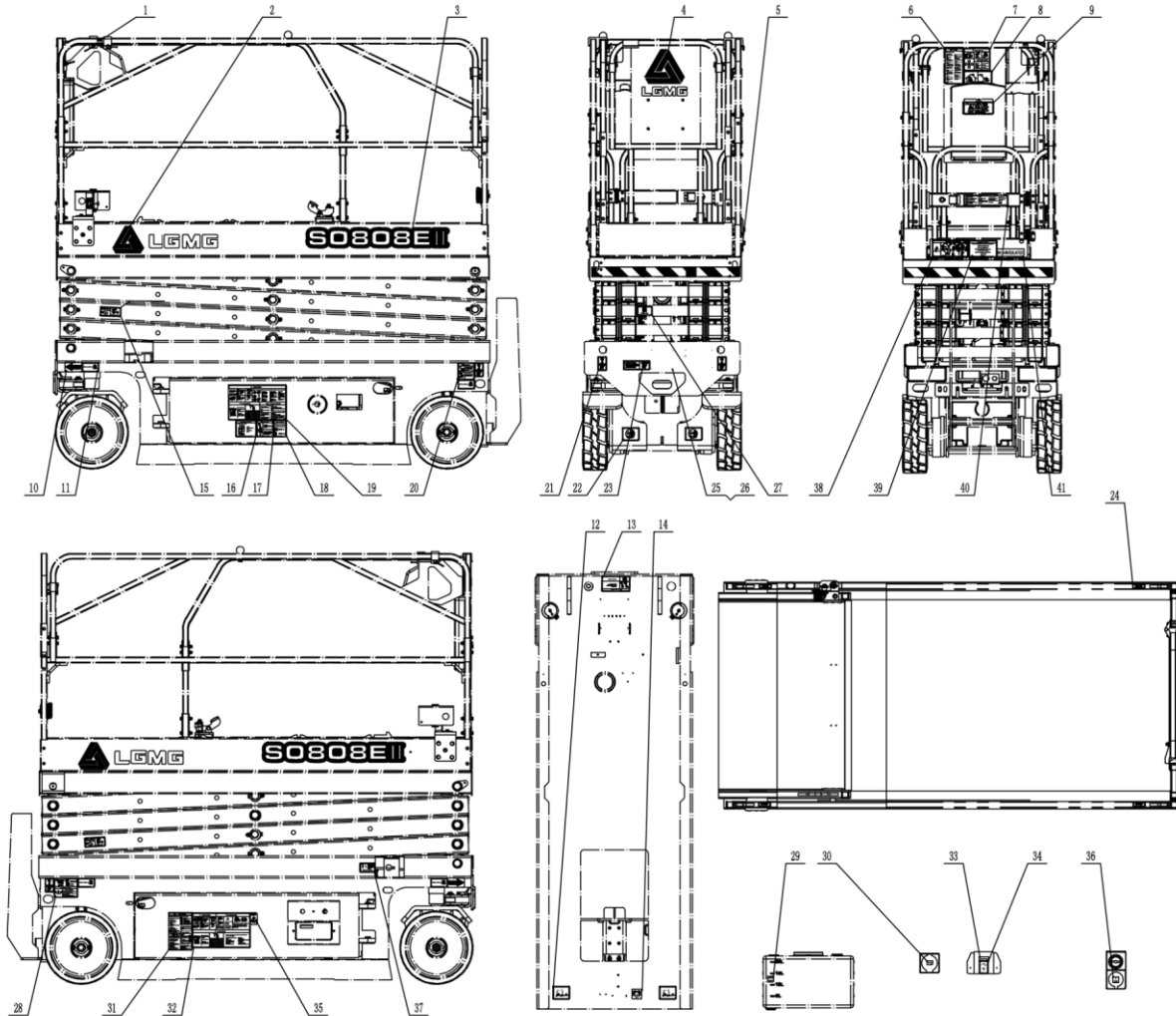



S0808E II Decal List

Item	Description	Item	Description
1	Hanger	21	Decal-Lifting
2	Decal-Company Logo	22	Decal-Lanyard anchorage point
3	Decal-Model	23	Decal-Transport tiedown
4	Decal-Group LOGO	24	Decal-Lanyard fixed point
5	Decal-Warning line	25	Decal-Machine nameplate
6	Note Description Identification	26	Bolt
7	Decal-Front guardrail	27	Fork safety arm
8	Decal-Warning, Shift	28	Decal-Warning, Brake release safety
9	Decal-Operation manual	29	Decal-Oil level
10	Direction of advance identification	30	Decal-Charging
11	Decal-Wheel load	31	Decal-Safe rules description
12	Decal-Forklift pocket	32	Decal-Oil tank side
13	Decal-Tilting risk	33	Decal-Platform power
14	Decal-Battery charging	34	Decal-Rated voltage
15	Decal-Stay away from machine	35	Decal-Ground control panel
16	Decal-Warning, Battery connection	36	Decal-Warning, Platform power
17	Warning sign for using batteries as counterweight	37	Decal-Emergency lowering
18	Decal-Turn off power	38	Decal-Warning, Platform safety
19	Decal-Battery side	39	Decal-Maximum hand power
20	Decal-Warning, Electric shock&fire	40	Decal-Operation Instruction



Operation Manual of Scissors Mobile Elevating Work Platform

S0808E II Decals

1-2534000975	2-2534000218	3-25340003220	4-25340000220	5-2534000024	6-2534000983
7-2534003214	8-2534003126	9-2534000986	10-2534000102	11-2534001044	12-2534000101
13-2534000987	14-2534004075	15-2534000973	16-2534001005	17-2534001038	18-2534001056
19-2534003212	20-2534000976	21-2534003217	22-2534000124	23-2534000304	24-2534000017
25\26-2534003309	27-2534000992	28-2534000991	29-2534000100	30-2534003298	31-2534000984
32-2534003213	33-2534003297	34-2534000038	35-2534000808	36-2534001803	37-2534000981
38-2534001114	39-2534001106	40-2534000997	41-2534004076		



S0812E II / S1012E II / S1212E II Decal Diagram

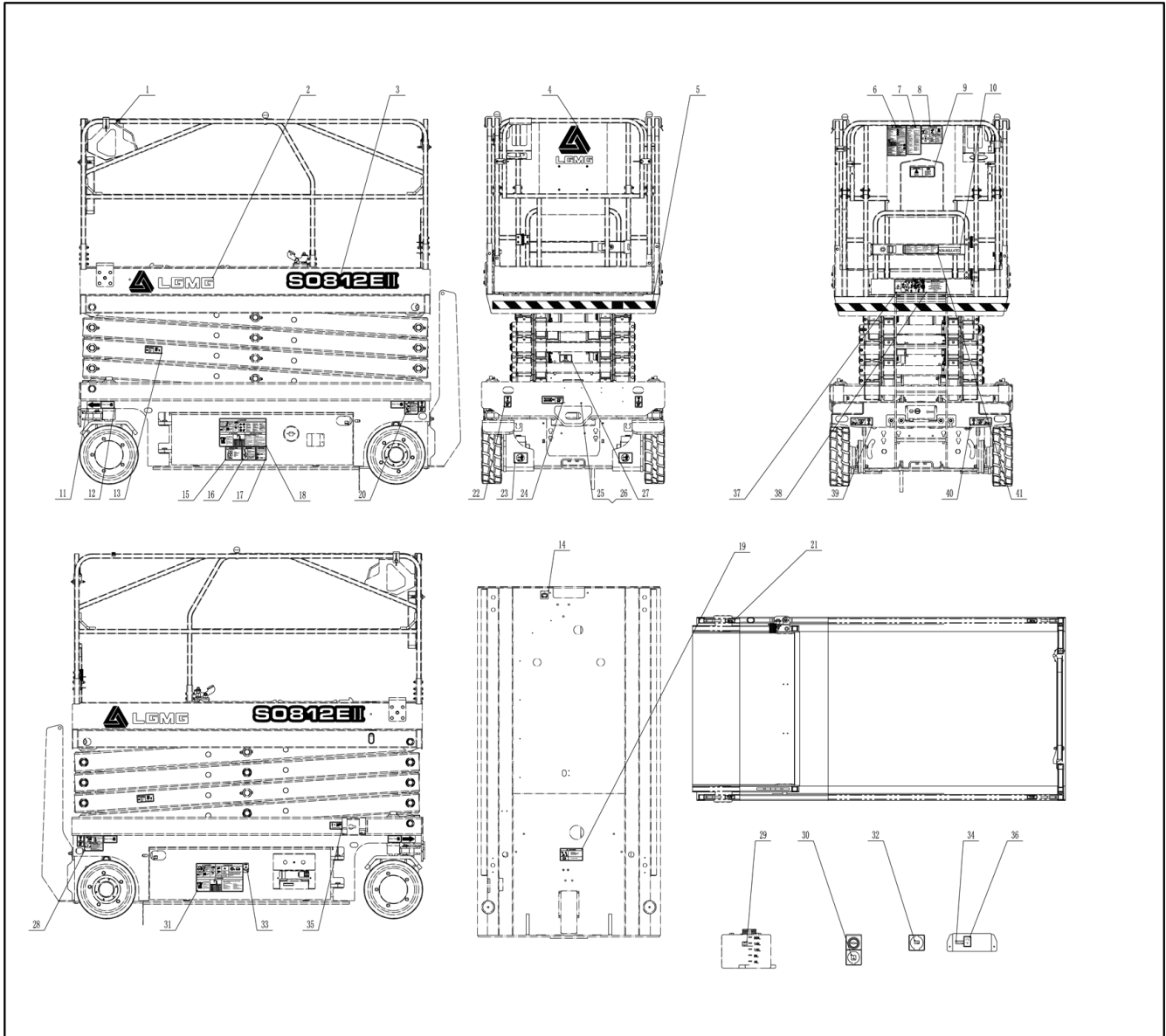



















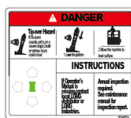

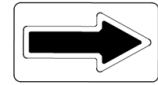

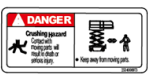
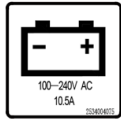

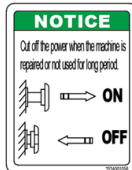



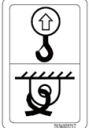

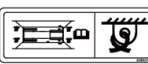



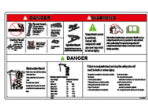

S0812E II /S1012E II/S1212E II Decal List

Item	Description	Item	Description
1	Hanger	22	Decal-Lifting
2	Decal-Company Logo	23	Decal-Lanyard anchorage point
3	Decal-Model	24	Decal-Transport tiedown
4	Decal-Group LOGO	25	Decal-Machine nameplate
5	Decal-Warning line	26	Bolt
6	Decal-Safe rules description	27	Fork safety arm
7	Note Description Identification	28	Decal-Warning, Brake release safety
8	Decal-Front guardrail	29	Decal-Oil level
9	Decal-Operation manual	30	Decal-Warning, Platform power
10	Decal-No-insulating	31	Decal-Oil tank side
11	Direction of advance identification	32	Decal-Charging
12	Decal-Wheel load	33	Decal-Ground control panel
13	Decal-Stay away from machine	34	Decal-Platform power
14	Decal-Battery charging	35	Decal-Emergency lowering
15	Decal-Warning, Battery connection	36	Decal-Rated voltage
16	Warning sign for using batteries as counterweight	37	Decal-Warning, Platform safety
17	Decal-Turn off power	38	Decal-Maximum hand power
18	Decal-Battery side	39	Decal-Forklift and lifting point
19	Decal-Tilting risk	40	Decal-Forklift and lifting point
20	Decal-Warning, Electric shock&fire	41	Decal-Operation instruction
21	Decal-Lanyard fixed point		



Operation Manual of Scissors Mobile Elevating Work Platform

S0812E II /S1012E II /S1212E II Decals

1-2534000975 	2-2534000218 	3-25340003222/224/159 	4-2534000220 	5-2534000024 	6-2534000984 
7-2534000983 	8-2534003214 	9-2534000986 	10-2534004076 	11-2534000102 	12-2534001043/17/90 
13-2534000973 	14-2534004075 	15-2534001023 	16-2534001021 	17-2534001056 	18-2534003212 
19-2534000987 	20-2534000976 	21-2534000017 	22-2534003217 	23-2534000124 	24-254001972 
25\26-2534003309 	27-2534000992 	28-2534001732 	29-2534000100 	30-2534001803 	31-2534003213 
32-2534003298 	33-2534000808 	34-2534003297 	35-2534000981 	36-2534000038 	37-2534001072/73 
38-2534001106 	39-2534003215 	40-2534003216 	41-2534000997 		



S1413E II Decal Diagram

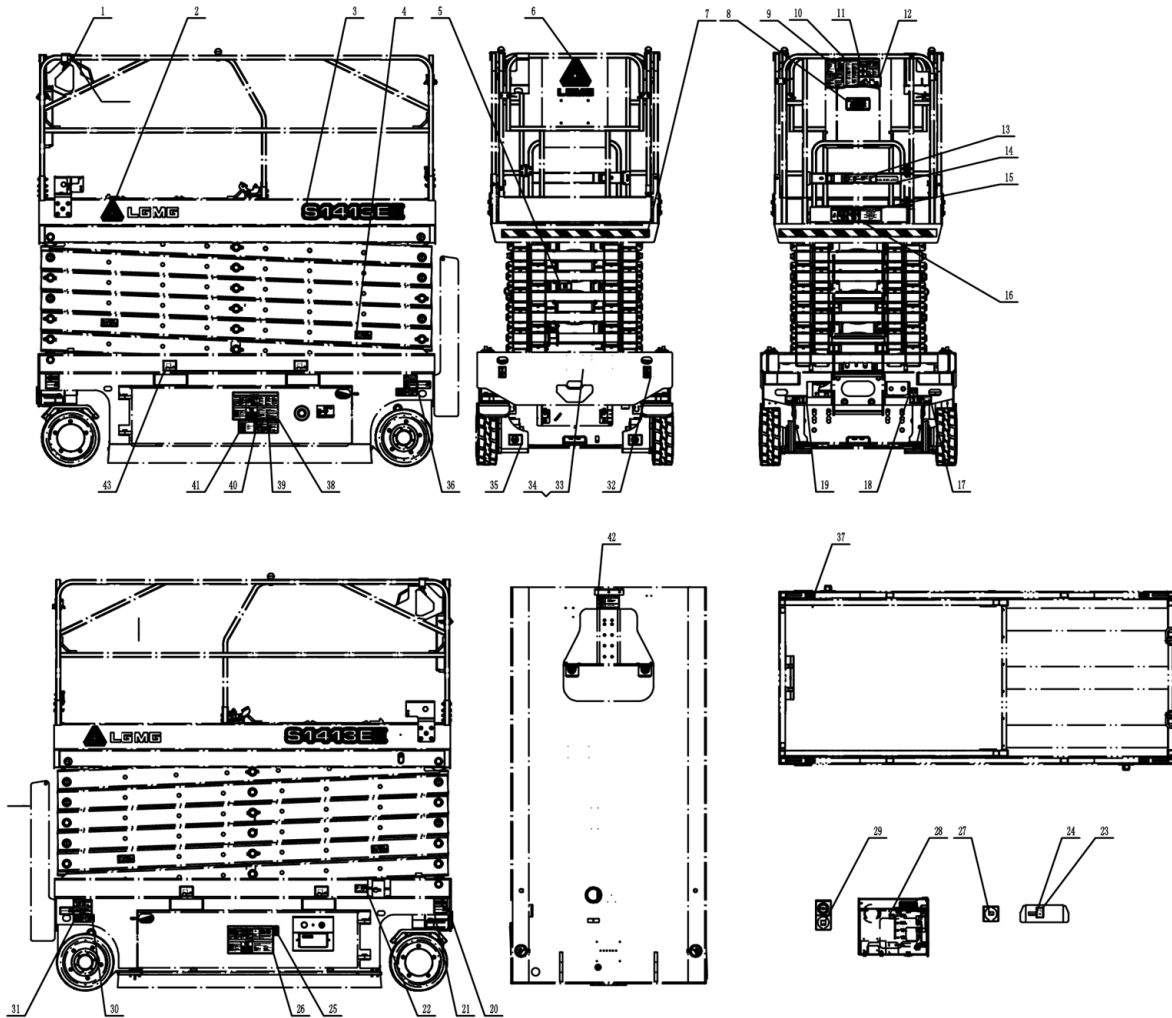





























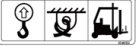
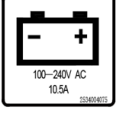
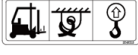

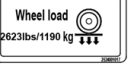

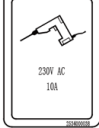





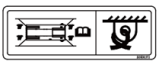
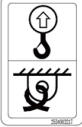

S1413E II Decal List

Item	Description	Item	Description
1	Hanger	23	Decal-Rated voltage
2	Decal-Company Logo	24	Decal-Platform power
3	Decal-Model	25	Decal-Ground control panel
4	Decal-Stay away from machine	26	Decal-Oil tank side
5	Fork safety arm	27	Decal-Charging
6	Decal-Group LOGO	28	Decal-Oil level
7	Decal-Warning line	29	Decal-Warning, Platform power
8	Decal-Operation manual	30	Decal-Warning, Brake release safety
9	Decal-Safe rules description	31	Decal-Transport tiedown
10	Note Description Identification	32	Decal-Lifting
11	Decal-Front guardrail	33	Decal-Machine nameplate
12	Decal-Warning, Shift	34	Bolt
13	Decal-Operation Instruction	35	Decal-Lanyard anchorage point
14	Decal-No-insulating	36	Decal-Warning, Electric shock&fire
15	Decal-Maximum hand power	37	Decal-Lanyard fixed point
16	Decal-Warning, Platform safety	38	Decal-Battery side
17	Decal-Forklift and Lifting point	39	Decal-Turn off power
18	Decal-Battery charging	40	Warning sign for using batteries as counterweight
19	Decal-Forklift and Lifting point	41	Decal-Warning, Battery connection
20	Direction of advance identification	42	Decal-Tilting risk
21	Decal-Wheel load	43	Decal-Forklift pocket
22	Decal-Emergency lowering		

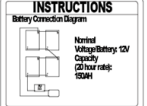

Operation Manual of Scissors Mobile Elevating Work Platform

S1413E II Decals

1-2534000975 	2-2534000218 	3-25340003227 	4-2534000973 	5-2534000992 	6-25340000220 
7-2534000024 	8-2534000986 	9-2534000984 	10-2534000983 	11-2534003214 	12-2534003336 
13-2534000997 	14-2534004076 	15-2534001106 	16-2534001073 	17-2534003216 	18-2534004075 
19-2534003215 	20-2534000102 	21-2534001111 	22-2534000981 	23-2534000038 	24-2534003297 
25-2534000808 	26-2534003213 	27-2534003298 	28-2534000100 	29-2534001803 	30-2534001732 
31-254001972 	32-2534003217 	33/34-2534003309 	35-2534000124 	36-2534000976 	37-2534000017 
38-2534003212 	39-2534001056 	40-2534001120 	41-2534001116 	42-2534000987 	43-2534000101 



Chapter 10 Specifications

Table 6 - Platform Load Capacity

Model	S0607E II			
Maximum occupant capacity	indoor	2	outdoor	1
Maximum working load of platform	indoor	230Kg	outdoor	230Kg
Recommend load capacity of extension deck	indoor	120Kg	outdoor	120Kg
Model	S0808E II			
Maximum occupant capacity	indoor	2	outdoor	1
Maximum working load of platform	indoor	230Kg	outdoor	230Kg
Recommend load capacity of extension deck	indoor	120Kg	outdoor	120Kg
Model	S0812E II			
Maximum occupant capacity	indoor	2	outdoor	1
Maximum working load of platform	indoor	450Kg	outdoor	450Kg
Recommend load capacity of extension deck	indoor	120Kg	outdoor	120Kg

Table 7 - Platform Load Capacity

Model	S1012E II			
Maximum occupant capacity	indoor	2	outdoor	1
Maximum working load of platform	indoor	320Kg	outdoor	320Kg
Recommend load capacity of extension deck	indoor	120Kg	outdoor	120Kg
Model	S1212E II			
Maximum occupant capacity	indoor	2	outdoor	1
Maximum working load of platform	indoor	320Kg	outdoor	320Kg
Recommend load capacity of extension deck	indoor	120Kg	outdoor	120Kg
Model	S1413E II			
Maximum occupant capacity	indoor	2	outdoor	1
Maximum working load of platform	indoor	320Kg	outdoor	320Kg
Recommend load capacity of extension deck	indoor	120Kg	outdoor	120Kg



Table 15- S0607E II Operating Specifications

The performance parameters of the whole machine

Items	Parameters	Items	Parameters
Rated load (kg)	230	Fork lifting time (S)	16±2
Extended platform load (kg)	120	Fork descending time (S)	28±3
Weight of the whole machine (kg)	1610	The maximum manual force	Indoor (N) 400
The maximum number of workers (indoor)	2		Outdoor (N) 200
The maximum number of workers (outdoor)	1	Theoretical maximum climbing ability (unloaded and with fork arms retracted) 25%	
Maximum working height (m)	5.8	The maximum allowable tilt angle	X direction: Left/right direction 1.5°
The maximum platform height (m)	5.8		Y direction: Front/rear direction 3°
The minimum turning radius (m)	1.8	The maximum inner wheel angle	70°
The maximum travelling speed (with fork arms retracted) (km/h)	3.5±0.2	The maximum allowable wind speed (m/s)	12.5
The maximum travelling speed (lifting) (km/h)	0.8±0.1	Driving type	Front wheel drive Front wheel steering
The maximum braking distance (unloaded and with fork arms retracted) (mm)	600		

Main dimensions

Items	Parameters	Items	Parameters
Overall length (with ladder, unfold/fold) (mm)	1860;1772	Extension size of the platform (mm)	900
Overall length (without ladder) (mm)	1679	Wheelbase (mm)	1350
Machine width (mm)	790	Tread (mm)	700
Height of the whole machine (guardrail in high position) (mm)	2150	The minimum ground clearance (with fork arms retracted) (mm)	50
Height of the whole machine (guardrail in low position) (mm)	2000	The minimum ground clearance (lifting) (mm)	26
Dimensions of the working bench (length × width) (mm)	1635×730	Tire size (diameter x width) (mm)	Φ323×100

Transmission system



Items		Parameters/Content
Travelling reducer	Rated output torque (Nm)	500

Hydraulic system

Items		Parameters/Content	
Functional system	Type	Open system	
	Pump displacement (ml/r)	3.1	
	Lifting system	The maximum working pressure (MPa)	19
	Steering system	The maximum working pressure (MPa)	12

Electrical system

Items		Parameters/Content	
Driving motor	Rated power (kW)	0.81	
Lifting motor	Rated power (kW)	2.4	
Battery	TROJAN	Output voltage (V)	6
		Capacity (Ah)	225(20 hours discharge rate)
	HOPPECKE	Output voltage (V)	6
		Capacity (Ah)	185(20 hours discharge rate)
Charger	Nominal AC input voltage (V)	100-240VAC	
	The maximum AC input current (A)	8.5	
	Nominal DC output voltage (V)	24	
	The maximum DC output current (A)	30	
Control system	Voltage (V)	24	

Oil filling amount

Items	Parameters/Content	Items	Parameters/Content
Hydraulic oil (L)	5	Gear oil for travelling reducer (L)	0.3

Floor loading information

Items	Parameters/Content	Items	Parameters/Content
Tire contact pressure (Kpa)	1220	Occupied floor pressure (Kpa)	11.9

Tire specification

Items	Parameters/Content	Items	Parameters/Content
Drive wheel load-6km/h (kg)	955	Maximum static load (kg)	1345



Table 16- S0808E II Operating Specifications

The performance parameters of the whole machine

Items	Parameters	Items	Parameters
Rated load (kg)	230	Fork lifting time (S)	31±3
Extended platform load (kg)	120	Fork descending time (S)	40±3
Weight of the whole machine (kg)	2200	The maximum manual force	Indoor (N) 400
The maximum number of workers (indoor)	2		Outdoor (N) 200
The maximum number of workers (outdoor)	1	Theoretical maximum climbing ability (unloaded and with fork arms retracted) 25%	
Maximum working height (m)	Indoor: 7.8 Outdoor: 6	The maximum allowable tilt angle	X direction: Left/right direction 1.5°
			Y direction: Front/rear direction 3°
The maximum platform height (m)	Indoor: 7.8 Outdoor: 6		
The minimum turning radius (m)	2.2	The maximum inner wheel angle	75°
The maximum travelling speed (with fork arms retracted) (km/h)	3.5±0.5	The maximum allowable wind speed (m/s)	12.5
The maximum travelling speed (lifting) (km/h)	0.8±0.1	Driving type	Front wheel drive Front wheel steering
The maximum braking distance (unloaded and with fork arms retracted) (mm)	600		

Main dimensions

Items	Parameters	Items	Parameters
Overall length (with ladder installed) (mm)	2440	Extension size of the platform (mm)	900
Overall length (without ladder) (mm)	2270	Wheelbase (mm)	1850
Machine width (mm)	830	Tread (mm)	700
Height of the whole machine (with guardrail not retracted) (mm)	2280	The minimum ground clearance (with fork arms retracted) (mm)	100
Height of the whole machine (with guardrail retracted) (mm)	1900	The minimum ground clearance (lifting) (mm)	20
Dimensions of the working bench (length × width) (mm)	2260×790	Tire size (diameter x width) (mm)	Φ380×130

Transmission system



Items		Parameters/Content
Travelling reducer	Rated output torque (Nm)	500

Hydraulic system

Items		Parameters/Content	
Functional system	Type	Open system	
	Pump displacement (ml/r)		4
	Lifting system	The maximum working pressure (MPa)	21
	Steering system	The maximum working pressure (MPa)	15

Electrical system

Items		Parameters/Content	
Driving motor	Rated power (kW)	0.81	
Lifting motor	Rated power (kW)	3.3	
Battery	TROJAN	Output voltage (V)	6
		Capacity (Ah)	225(20 hours discharge rate)
	HOPPECKE	Output voltage (V)	6
		Capacity (Ah)	220(20 hours discharge rate)
Charger	Nominal AC input voltage (V)		100-240VAC
	The maximum AC input current (A)		8.5
	Nominal DC output voltage (V)		24
	The maximum DC output current (A)		30
Control system	Voltage (V)	24	

Oil filling amount

Items	Parameters/Content	Items	Parameters/Content
Hydraulic oil (L)	13	Gear oil for travelling reducer (L)	0.3

Floor loading information

Items	Parameters/Content	Items	Parameters/Content
Tire contact pressure (Kpa)	1240	Occupied floor pressure (Kpa)	11.4

Tire specification

Items	Parameters/Content	Items	Parameters/Content
Drive wheel load-6km/h (kg)	1395	Maximum static load (kg)	1630



Table 17- S0812E II Operating Specifications

The performance parameters of the whole machine

Items	Parameters	Items	Parameters
Rated load (kg)	450	Fork lifting time (S)	35±4
Extended platform load (kg)	120	Fork descending time (S)	40±4
Weight of the whole machine (kg)	2318	The maximum manual force	Indoor (N) 400
The maximum number of workers (indoor)	2		Outdoor (N) 200
The maximum number of workers (outdoor)	1	Theoretical maximum climbing ability (unloaded and with fork arms retracted) 25%	
Maximum working height (m)	8	The maximum allowable tilt angle	X direction: Left/right direction 1.5°
The maximum platform height (m)	8		Y direction: Front/rear direction 3°
The minimum turning radius (m)	2.45	The maximum inner wheel angle	78°
The maximum travelling speed (with fork arms retracted) (km/h)	3.5±0.2	The maximum allowable wind speed (m/s)	12.5
The maximum travelling speed (lifting) (km/h)	0.8±0.1	Driving type	Front wheel drive Front wheel steering
The maximum braking distance (unloaded and with fork arms retracted) (mm)	600		

Main dimensions

Items	Parameters	Items	Parameters
Overall length (with ladder installed) (mm)	2490	Extension size of the platform (mm)	900
Overall length (without ladder) (mm)	2270	Wheelbase (mm)	1850
Machine width (mm)	1180	Tread (mm)	1050
Height of the whole machine (with guardrail not retracted) (mm)	2360	The minimum ground clearance (with fork arms retracted) (mm)	100
Height of the whole machine (with guardrail retracted) (mm)	1550	The minimum ground clearance (lifting) (mm)	20
Dimensions of the working bench (length × width) (mm)	2260×1120	Tire size (diameter x width) (mm)	Φ380×130

Transmission system



Items		Parameters/Content
Travelling reducer	Rated output torque (Nm)	500

Hydraulic system

Items		Parameters/Content	
Functional system	Type	Open system	
	Pump displacement (ml/r)		4.5
	Lifting system	The maximum working pressure (MPa)	21
	Steering system	The maximum working pressure (MPa)	15

Electrical system

Items		Parameters/Content	
Driving motor	Rated power (kW)	0.81	
Lifting motor	Rated power (kW)	4.5	
Battery	TROJAN	Output voltage (V)	6
		Capacity (Ah)	240(20 hours discharge rate)
	HOPPECKE	Output voltage (V)	6
		Capacity (Ah)	226(20 hours discharge rate)
Charger	Nominal AC input voltage (V)		100-240VAC
	The maximum AC input current (A)		8.5
	Nominal DC output voltage (V)		24
	The maximum DC output current (A)		30
Control system	Voltage (V)	24	

Oil filling amount

Items	Parameters/Content	Items	Parameters/Content
Hydraulic oil (L)	16	Gear oil for travelling reducer (L)	0.3

Floor loading information

Items	Parameters/Content	Items	Parameters/Content
Tire contact pressure (Kpa)	1201	Occupied floor pressure (Kpa)	8.5

Tire specification

Items	Parameters/Content	Items	Parameters/Content
Drive wheel load-6km/h (kg)	1395	Maximum static load (kg)	1630



Table 18- S1012E II Operating Specifications

The performance parameters of the whole machine

Items	Parameters	Items	Parameters
Rated load (kg)	320	Fork lifting time (S)	58±4
Extended platform load (kg)	120	Fork descending time (S)	48±4
Weight of the whole machine (kg)	2995	The maximum manual force	Indoor (N) 400
The maximum number of workers (indoor)	2		Outdoor (N) 200
The maximum number of workers (outdoor)	1	Theoretical maximum climbing ability (unloaded and with fork arms retracted) 25%	
Maximum working height (m)	10	The maximum allowable tilt angle	X direction: Left/right direction 1.5°
The maximum platform height (m)	10		Y direction: Front/rear direction 3°
The minimum turning radius (m)	2.45	The maximum inner wheel angle	75°
The maximum travelling speed (with fork arms retracted) (km/h)	3.5±0.2	The maximum allowable wind speed (m/s)	12.5
The maximum travelling speed (lifting) (km/h)	0.8±0.1	Driving type	Front wheel drive Front wheel steering
The maximum braking distance (unloaded and with fork arms retracted) (mm)	600		

Main dimensions

Items	Parameters	Items	Parameters
Overall length (with ladder installed) (mm)	2490	Extension size of the platform (mm)	900
Overall length (without ladder) (mm)	2270	Wheelbase (mm)	1850
Machine width (mm)	1180	Tread (mm)	1050
Height of the whole machine (with guardrail not retracted) (mm)	2490	The minimum ground clearance (with fork arms retracted) (mm)	100
Height of the whole machine (with guardrail retracted) (mm)	1675	The minimum ground clearance (lifting) (mm)	20
Dimensions of the working bench (length × width) (mm)	2260×1120	Tire size (diameter x width) (mm)	Φ380×130

Transmission system



Items		Parameters/Content
Travelling reducer	Rated output torque (Nm)	500

Hydraulic system

Items		Parameters/Content	
Functional system	Type	Open system	
	Pump displacement (ml/r)	4.5	
	Lifting system	The maximum working pressure (MPa)	21
	Steering system	The maximum working pressure (MPa)	15

Electrical system

Items		Parameters/Content	
Driving motor	Rated power (kW)	0.81	
Lifting motor	Rated power (kW)	4.5	
Battery	TROJAN	Output voltage (V)	6
		Capacity (Ah)	240(20 hours discharge rate)
	HOPPECKE	Output voltage (V)	6
		Capacity (Ah)	226(20 hours discharge rate)
Charger	Nominal AC input voltage (V)	100-240VAC	
	The maximum AC input current (A)	8.5	
	Nominal DC output voltage (V)	24	
	The maximum DC output current (A)	30	
Control system	Voltage (V)	24	

Oil filling amount

Items	Parameters/Content	Items	Parameters/Content
Hydraulic oil (L)	23	Gear oil for travelling reducer (L)	0.3

Floor loading information

Items	Parameters/Content	Items	Parameters/Content
Tire contact pressure (Kpa)	1311.7	Occupied floor pressure (Kpa)	10.96

Tire specification

Items	Parameters/Content	Items	Parameters/Content
Drive wheel load-6km/h (kg)	1395	Maximum static load (kg)	1630



Table 19- S1212E II Operating Specifications

The performance parameters of the whole machine

Items	Parameters	Items	Parameters
Rated load (kg)	320	Fork lifting time (S)	65±4
Extended platform load (kg)	120	Fork descending time (S)	60±4
Weight of the whole machine (kg)	2970	The maximum manual force	Indoor (N) 400
The maximum number of workers (indoor)	2		Outdoor (N) 200
The maximum number of workers (outdoor)	1	Theoretical maximum climbing ability (unloaded and with fork arms retracted) 25%	
Maximum working height (m)	Indoor: 12 Outdoor: 7.5	The maximum allowable tilt angle	X direction: Left/right direction 1.5°
			Y direction: Front/rear direction 3°
The maximum platform height (m)	Indoor: 12 Outdoor: 7.5		
The minimum turning radius (m)	2.45	The maximum inner wheel angle	75°
The maximum travelling speed (with fork arms retracted) (km/h)	3.5±0.2	The maximum allowable wind speed (m/s)	12.5
The maximum travelling speed (lifting) (km/h)	0.8±0.1	Driving type	Front wheel drive Front wheel steering
The maximum braking distance (unloaded and with fork arms retracted) (mm)	600		

Main dimensions

Items	Parameters	Items	Parameters
Overall length (with ladder installed) (mm)	2490	Extension size of the platform (mm)	900
Overall length (without ladder) (mm)	2270	Wheelbase (mm)	1850
Machine width (mm)	1180	Tread (mm)	1050
Height of the whole machine (with guardrail not retracted) (mm)	2630	The minimum ground clearance (with fork arms retracted) (mm)	100
Height of the whole machine (with guardrail retracted) (mm)	1800	The minimum ground clearance (lifting) (mm)	20
Dimensions of the working bench (length × width) (mm)	2260×1120	Tire size (diameter x width) (mm)	Φ380×130

Transmission system



Items		Parameters/Content
Travelling reducer	Rated output torque (Nm)	500

Hydraulic system

Items		Parameters/Content	
Functional system	Type	Open system	
	Pump displacement (ml/r)	4.5	
	Lifting system	The maximum working pressure (MPa)	21
	Steering system	The maximum working pressure (MPa)	15

Electrical system

Items		Parameters/Content	
Driving motor	Rated power (kW)	0.81	
Lifting motor	Rated power (kW)	4.5	
Battery	TROJAN	Output voltage (V)	12
		Capacity (Ah)	150(20 hours discharge rate)
	HOPPECKE	Output voltage (V)	6
		Capacity (Ah)	226(20 hours discharge rate)
Charger	Nominal AC input voltage (V)	100-240VAC	
	The maximum AC input current (A)	8.5	
	Nominal DC output voltage (V)	24	
	The maximum DC output current (A)	30	
Control system	Voltage (V)	24	

Oil filling amount

Items	Parameters/Content	Items	Parameters/Content
Hydraulic oil (L)	23	Gear oil for travelling reducer (L)	0.3

Floor loading information

Items	Parameters/Content	Items	Parameters/Content
Tire contact pressure (Kpa)	1262.1	Occupied floor pressure (Kpa)	10.86

Tire specification

Items	Parameters/Content	Items	Parameters/Content
Drive wheel load-6km/h (kg)	1395	Maximum static load (kg)	1630



Table 20- S1413E II Operating Specifications

The performance parameters of the whole machine

Items	Parameters	Items	Parameters
Rated load (kg)	320	Fork lifting time (S)	80±4
Extended platform load (kg)	120	Fork descending time (S)	65±4
Weight of the whole machine (kg)	3500	The maximum manual force	Indoor (N) 400
The maximum number of workers (indoor)	2		Outdoor (N) 200
The maximum number of workers (outdoor)	1	Theoretical maximum climbing ability (unloaded and with fork arms retracted) 25%	
Maximum working height (m)	Indoor: 13.8 Outdoor: 8	The maximum allowable tilt angle	X direction: Left/right direction 1.5°
The maximum platform height (m)	Indoor: 13.8 Outdoor: 8		Y direction: Front/rear direction 3°
The minimum turning radius (m)	2.85	The maximum inner wheel angle	75°
The maximum travelling speed (with fork arms retracted) (km/h)	3.5±0.2	The maximum allowable wind speed (m/s)	12.5
The maximum travelling speed (lifting) (km/h)	0.8±0.1	Driving type	Front wheel drive Front wheel steering
The maximum braking distance (unloaded and with fork arms retracted) (mm)	600		

Main dimensions

Items	Parameters	Items	Parameters
Overall length (with ladder installed) (mm)	2800	Extension size of the platform (mm)	900
Overall length (without ladder) (mm)	2650	Wheelbase (mm)	2220
Machine width (mm)	1300	Tread (mm)	1175
Height of the whole machine (with guardrail not retracted) (mm)	2740	The minimum ground clearance (with fork arms retracted) (mm)	105
Height of the whole machine (with guardrail retracted) (mm)	1940	The minimum ground clearance (lifting) (mm)	20
Dimensions of the working bench (length × width) (mm)	2640×1120	Tire size (diameter x width) (mm)	Φ380×130

Transmission system



Items		Parameters/Content
Travelling reducer	Rated output torque (Nm)	500

Hydraulic system

Items		Parameters/Content	
Functional system	Type	Open system	
	Pump displacement (ml/r)		4.5
	Lifting system	The maximum working pressure (MPa)	21
	Steering system	The maximum working pressure (MPa)	16.5

Electrical system

Items		Parameters/Content	
Driving motor	Rated power (kW)	0.81	
Lifting motor	Rated power (kW)	4.5	
Battery	TROJAN	Output voltage (V)	12
		Capacity (Ah)	150(20 hours discharge rate)
	HOPPECKE	Output voltage (V)	12
		Capacity (Ah)	140(20 hours discharge rate)
Charger	Nominal AC input voltage (V)		100-240VAC
	The maximum AC input current (A)		8.5
	Nominal DC output voltage (V)		24
	The maximum DC output current (A)		30
Control system	Voltage (V)	24	

Oil filling amount

Items	Parameters/Content	Items	Parameters/Content
Hydraulic oil (L)	25.5	Gear oil for travelling reducer (L)	0.3

Floor loading information

Items	Parameters/Content	Items	Parameters/Content
Tire contact pressure (Kpa)	1255.6	Occupied floor pressure (Kpa)	10.1

Tire specification

Items	Parameters/Content	Items	Parameters/Content
Drive wheel load-6km/h (kg)	1395	Maximum static load (kg)	1630



 NOTICE:

The ground bearing information is approximate information, and the different options are not included. The information can be used only if the safety factor is high enough. The weight of the machine varies according to the configuration of the selected part.

10.1 Hydraulic Oil Specifications

 NOTICE

When filling the hydraulic oil tank, it is a requirement to use the proper hydraulic oil in accordance with the work site environment and ambient temperature with reference to the following:

Grade	Brand
Rando MV32	Chevron



Chapter 11 Maintenance Schedule

Routine inspection and maintenance interval table

Maintenance level	Routine inspection	Level I	Level II	Level III	Level IV	Level V
Maintenance period	Every day	25h/1m	50h/3m	100h/6m	200h/12m	400h/24m



NOTICE: Working hours is based on those shown on the hourmeter.

Maintenance items of every level are given in the following tables

Item	Description	Maintenance Level					
		Routine inspection	I	II	III	IV	V
Electric system	Check battery capacity	•	•	•	•	•	•
	Check that all buttons/switches on the PCU panel function normally	•	•	•	•	•	•
	Ensure the PCU emergency stop switch is secure	•	•	•	•	•	•
	Check if all switches operate properly	•	•	•	•	•	•
	Check if any wiring harnesses are damaged	•	•	•	•	•	•
	Ensure the PCU wiring harness connector is secure	•	•	•	•	•	•
	Check if the PCU wiring harness connector is not damaged	•	•	•	•	•	•
	Check if the PCU wiring harness is crimped or damaged	•	•	•	•	•	•
	Check if the pressure switch wiring is secure and not damaged	•	•	•	•	•	•
	Check if the lowering solenoid valve is secure and not damaged	•	•	•	•	•	•
	Check if the wirings of horizon sensor and inclination sensor are secure and not damaged	•	•	•	•	•	•
	Check the position and wiring of every limit switch rocker arm	•	•	•	•	•	•
	Ensure the angle sensor wiring harness and connector are secure and not	•	•	•	•	•	•



Operation Manual of Scissors Mobile Elevating Work Platform

Item	Description	Maintenance Level					
		Routine inspection	I	II	III	IV	V
	damaged						
	Ensure the emergency stop switch, key switch and plug switch on the lowering control panel and their wiring are secure and not damaged	•	•	•	•	•	•
	Ensure the warning lamp and horn function normally	•	•	•	•	•	•
	Ensure the motor, motor controller, relay and ECU wirings are secure and not damaged	•	•	•	•	•	•
	Ensure the wiring of every solenoid valve on the main valve block is secure and not damaged	•	•	•	•	•	•
	Ensure the charger wiring is secure and not corroded	•	•	•	•	•	•
	Ensure the battery posts are secure and not corroded	•	•	•	•	•	•
	Check the battery is secure and not damaged	•					
	Check machine performance and various limit switches	•					
	Check if any connector is loose, damaged or corroded	•	•	•	•	•	•
	Calibrate the load cell				•	•	•
Hydraulic System	Check if the pressure of the hydraulic system is normal	•	•	•	•	•	•
	Check if the lift system hydraulic pressure is normal	•	•	•	•	•	•
	Check if the steering system hydraulic pressure is normal	•	•	•	•	•	•
	Check if the driving system hydraulic pressure is normal (If equipped)	•	•	•	•	•	•
	Check if any oil line or connector is loose or damaged	•	•	•	•	•	•
	Check all hydraulic cylinders for damage or leaking	•	•	•	•	•	•
	Check every hydraulic valve for damage or leaking	•	•	•	•	•	•
	Check if the scissor stack arm oil line is securely fastened or damaged	•	•	•	•	•	•
	Check if the driving oil pipe clip is loose	•	•	•	•	•	•
	Check oil level in the hydraulic tank	•	•	•	•	•	•



Operation Manual of Scissors Mobile Elevating Work Platform

Item	Description	Maintenance Level					
		Routine inspection	I	II	III	IV	V
	Replace the hydraulic oil	Yearly					
	Hydraulic oil return filter element	Every 6 months					
	Check the hydraulic oil tank vent cap for leaks		•	•	•	•	•
	Replace the hydraulic oil tank vent cap			•	•	•	
	Replace the reducer lubricating oil	Firstly 50 hours, every 200 hours					
Whole machine	Check the fork sliding block for abnormal noise					•	•
	Check and replace the sliding block					•	•
	Check for loose or damaged bolts or abnormal noise	•					
	Check if any circlip or washer on fork arms are damaged, worn, or missing	•					
	Check if the emergency lowering system operates properly	•					
	Check if the platform, scissor stack arm, and chassis are deformed or have broken welds	•					
	Check if the paint is excessively chips or peels off	•					
	Check if the decals and safety signs are correct and legible	•					
	Check if the manuals are with the machine	•					
	Machine performance and limit switches operate properly	•					
Lubrication	Lubricate the steering knuckle	Once a month					

Hydraulic Oil Specifications



Grade	Brand
Rando MV32	Chevron

Gear Oil Specifications

Condition	Grade	Remarks
30°C < Minimum temperature	SAE, 85W/140	API GL-5
-10°C < Minimum temperature <30°C	SAE, 85W/90	
-30°C < Minimum temperature <-10°C	SAE, 80W/90	
Minimum temperature <-30°C	SAE, 75W	