



Maintenance Manual

AS10896.1

H730

Telehandler

PART No. MM-2537060084

Original Instructions

Original Instructions

Thank you for choosing to use this Mobile Elevating Work Platform from LGMG, All models are designed and manufactured according to AS10896.1.

This manual is a guide for safe and proper operation and maintenance of the machine, which introduces maintenance and operation herein.

We sincerely hope that you will read through this manual before attempting to operate the machine for the first time and before repairing and maintaining the machine, and that you will master the operation and maintenance described therein.

The information contained in this manual is correct at the time of publication. However, LGMG has endeavored to deliver the highest degree of accuracy possible. And continuous improvement of our product is a LGMG policy. Therefore, product specifications are subject to change without notice.

Due to the impossibility of foreseeing all possible hazards, therefore, it is not possible to include all safety precautions in this manual and the machine's safety precautions in this manual and the machine's safety instructions. If some operations that are not recommended in this manual, you must ensure that you and others are safe and will not damage the machine. If the security of certain operations cannot be determined, please call LGMG industries or dealer service center.

The precautions for operation and maintenance contained in this manual are only applicable when the machine is used for the specified use. If the machine is used within the scope not listed in this manual, our company will not assume any safety responsibility, which is borne by the user and operator in such operations.

Any prohibited operations in this manual shall not be performed.

This manual should always be placed in the designated location for read. This manual is part of the machine, when the ownership or use right of the machine is transferred, please hand over this manual together. If the manual is lost, damaged or illegible, please replace it promptly.

The copyright of this manual this manual is authorized to LGMG and it cannot be copied or reprinted without LGMG's written permission.

2025-12 Version 1 Printed 1

L I N G O N G H E A V Y M A C H I N E R Y C O . , L T D .

Add: 2676 Kejia Road, high tech Zone, Jinan City, Shandong Province, China

Tel: 86-0531-67601108

Fax: 86-0531-67601108

Service Tel: 86-0531-67605016

Web: www.lgmg.com.cn



Safety Notices

The operator shall understand and abide by the current national and local safety regulations. If such regulations are not available, the safety instructions in this manual shall prevail.

Most accidents are caused by failure to obey operation and maintenance specifications of the machine. To avoid unnecessary accident, please read and follow all warnings and precautions in this manual and on the machine before operation or maintenance.

Considering the fact that not all possible hazards are foreseeable, it is impossible for safety notices in this manual and on the machine to cover all safety precautions. If it is necessary to take steps and operations not recommended herein, always protect the safety of yourself and others, and keep the machine from any damage. If the safety of some operations remains uncertain, please consult us or dealers.

The operation and maintenance precautions referred to herein apply only to the intended use of this machine. If the machine is to be used for other purposes than those listed herein, it is the user or operator instead of us that shall take the safety liabilities therefrom.

In no case shall any operations expressly prohibited herein be performed.

For the purpose of this manual, the following signal words are applied to identify safety instructions:

 **DANGER** - Indicating any existing dangers that, if not avoided, will cause serious injury or even death, and also serious machine damage.

 **WARNING** - Indicating any potential dangers that, if not avoided, may cause death or serious injury, and also serious machine damage.

 **CAUTION** - Indicating situations that, if not avoided, may cause minor or moderate injury, and also machine damage or shortened machine service life.





Contents

Safety Notices	III
Contents	V
Chapter 1 Maintenance	2
1.1 Checking the safety manual.....	4
1.2 Checking the labels and signs	4
1.3 Checking for damaged, loose or missing parts	4
1.4 Daily or every 8 hours	5
1.5 Every 50 hours or weekly.....	8
1.6 Every 250 hours.....	10
1.7 Every 500 hours.....	12
1.8 Every 1000 hours.....	18
1.9 Every 1500 hours.....	21
1.10 Every 2000 hours.....	22
1.11 Appendix	25





Chapter 1 Maintenance





1.1 Checking the safety manual

It is essential to keep the operation and maintenance manuals in good condition to achieve safe operation of the equipment. If the manual is illegible or missing, the safety and operation information necessary for safe running cannot be provided.

- 1) Confirm that the Operation Manual and the Maintenance Manual are kept intact in the cab.
- 2) Check that every page of the manual is legible and intact.
- 3) Put the manual in the cab after use.



To replace any manual, please contact the service personnel of LGMG.

1.2 Checking the labels and signs

It is essential to keep all safety and description labels and signs in good condition to achieve safe operation of the equipment. Labels are used to remind the operation and maintenance personnel of potential hazards during operation of the equipment and provide operation and maintenance information for users. Illegible labels cannot remind the maintenance personnel of procedures or hazards and may also lead to unsafe

operation.

Check whether all labels are in proper positions with reference to the label section in this manual and based on the label menu and description.

Check the legibility and condition of all labels, and replace the damaged or illegible labels promptly if any.



To replace the labels, please contact the service personnel of LGMG.

1.3 Checking for damaged, loose or missing parts

This procedure shall be implemented once every 8h or every day.

It is essential to check the equipment condition regularly to achieve safe operation and superior performance of the equipment. Incorrect positioning or maintenance and part damage, looseness or loss may lead to unsafe operation.

- 1) Check the equipment for damage, incorrect installation or part loss, including:
 - Electrical component, wire and cable
 - Hydraulic hose, connector, valve block and hydraulic cylinder
 - Fuel tank and hydraulic tank



- Sliders
- Tires and hubs
- Engine and its relevant parts
- Sensor and horn
- Nuts, bolts and other fasteners
- Outrigger mechanism
- Brake pedal and parking brake
- Indicator light and alarm
- Drive shaft

2) Inspect the entire machine to check:

- the welds or structural parts for cracks
- the chassis for deformation or open weld
- the machine for dent or damage
- that all structural parts and other key components are intact and all relevant fasteners and pins are installed in correct positions and tightened

3) Regular maintenance

In a working environment where is extremely cold, dusty or humid, more frequent lubrication and maintenance than that is specified in "Regular Maintenance" is required. During maintenance, the maintenance items listed in the original requirements shall be carried out repeatedly.

For example, when carrying out maintenance items for 250 working hours, the maintenance items for 50 working hours or weekly and every 8 working hours or daily shall be carried out at the same time.

During maintenance, the engine shall be stopped, the machine shall be parked on a level ground, the gear selector shall be set to N gear, the parking brake handle shall be pulled up, and the padding block shall be placed under the tires to prevent the machine from moving.

1.4 Daily or every 8 hours

1.4.1 Checking the engine oil level

Insufficient or excessive oil will cause engine damage. The oil level can be checked only when the engine is placed horizontally and shut down. If the engine is hot, shut it down and check the oil level after 10 minutes so that the engine oil can be discharged into the oil pan. If the engine is cold, check the oil level immediately.



Kubota V3307:

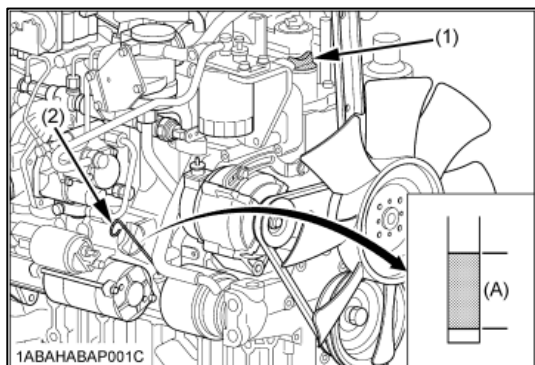

- 1 Oil filler plug
- 2 Oil dipstick

- 1) Pull out the oil dipstick and wipe it with a clean cloth, re-insert it into the engine oil level port to the end, and then pull it out for inspection. The oil level should be between the "L" mark and the "H" mark of the oil dipstick.



- 2) If the oil level is below the "L" scale, please add oil; If the oil level is above the "H" mark, unscrew the drain plug at the bottom of the oil pan to discharge some oil.

⚠ CAUTION: Too much or too little engine oil will cause engine damage.

1.4.2 Checking the coolant level

Check the coolant level every 8 hours or every day, whichever comes first.

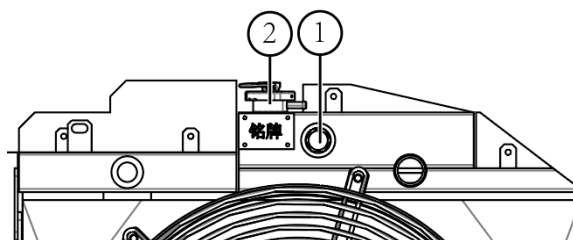
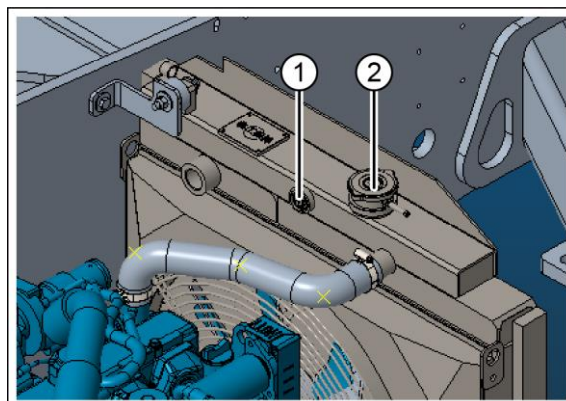

- 1 Sight hole
- 2 Filler (with relief valve)

- 1) Place the telescopic handler on the horizontal ground, stop the engine and wait till it is cool.
- 2) The coolant level shall not be lower than the middle position of the sight hole.
- 3) If necessary, add coolant through the filler.

⚠ In order to avoid the risk of scalding, wait until the engine is cool enough before removing the cooling circuit filler cap.

1.4.3 Checking the fuel level

Check every 8 hours or every day, whichever comes first.



- 1) Check the fuel level via the fuel level gauge on the instrument panel.
- 2) Keep the fuel tank full to minimize any condensation due to atmospheric conditions.

! CAUTION: Adding should be always carried out before the diesel in the diesel tank is used up, or, the engine will stall and the diesel at the bottom of the diesel tank will contain more water and impurities, which will affect the normal operation of the engine.

! CAUTION: The fuel shall be selected according to the lowest local temperature when the machine is in use.

1.4.4 Draining water from the fuel filter

Drain it every 8 hours or every day, whichever comes first.

! Explosion and fire hazard. Engine fuel is combustible. Check the location of

the equipment. This step shall be performed in open and well-ventilated areas away from heaters, sparks, flames, and burning tobacco. A conforming fire extinguisher should be placed in an easily accessible place.

! This step shall be performed when the engine is shut down.

Kubota V3307:

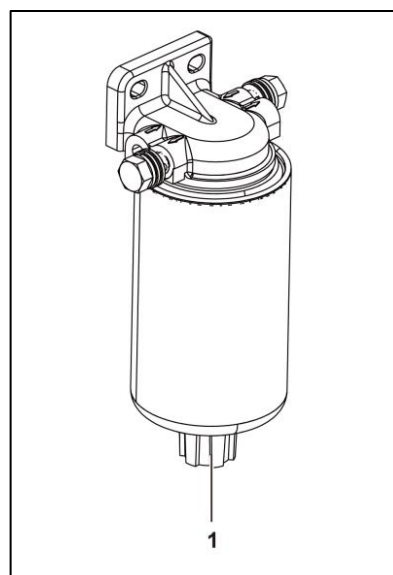

1. Drain valve

- 1) Place the container under the drain valve.
- 2) Open the drain valve to drain the liquid from the filter and close the drain valve immediately when the clean fuel is drained.
- 3) Wipe away the spilled fuel oil.

1.4.5 Checking the tire pressure and wheel nut torque

Drain it every 8 hours or every day,



whichever comes first.

- 1) Check treads and sides of tires for scratches, cracks, punctures, and other abnormal wear.
- 2) Check if the hubs are damaged, bent or cracked.
- 3) Check and adjust the tire pressure if necessary:

Model	Speed (km/h)	Single tire load (Kg)	Tire pressure (kpa)
H730	30	4500	690

Tightening torque of wheel nut:

Model	Front axle	Rear axle
H730	600N.m	600N.m

! CAUTION: Check whether the air hose is properly connected to the tire valve before inflation and keep a certain distance from everyone during inflation.

1.4.6 Checking the hydraulic oil level

Check every 8 hours or every day, whichever comes first.



When checking the hydraulic oil level,

park the handler on a flat ground. The hydraulic oil level for storage shall be not less than 1/2 of the level meter.

When there is no level gauge, check the hydraulic oil level through the dashboard  , the stored hydraulic oil volume shall not be less than 90%.

1.5 Every 50 hours or weekly

1.5.1 Cleaning radiator

This item is performed every 50 hours or weekly, whichever comes first.

Clean and flush the cooling system before the recommended maintenance interval if the following conditions occur:

- The engine overheats frequently.
- Coolant foaming was observed.
- The oil has entered the cooling system and the coolant is contaminated.
- The diesel fuel has entered the cooling system and the coolant is contaminated.

! CAUTION: Cleaning radiator should always be carried out when the engine is shut down.

! CAUTION: If the operation isn't performed carefully, the radiator core will be prone to damage.

- 1) Clean the radiator through blowing from



the air outlet side of the radiator with compressed air.

- 2) Clean the inside of the radiator with a soft cloth.

1.5.2 Checking washer fluid level

This item is performed every 50 hours or weekly, whichever comes first.



- 1) Remove protective cover.
- 2) Check the level in the water tank.
- 3) If necessary, add washer fluid by filler.

1.5.3 Cleaning the cab A/C filter

This item is performed every 50 hours or weekly, whichever comes first.

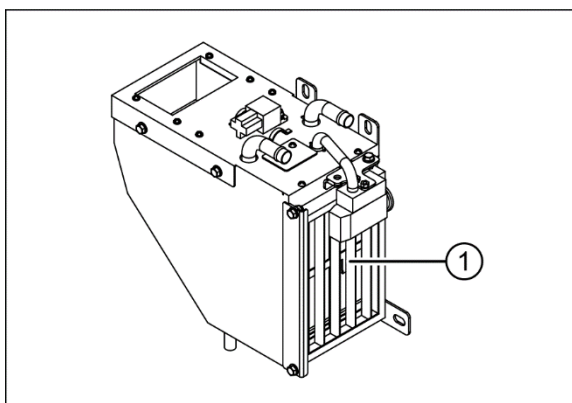

- 1) Remove the rocker switch panel on the dashboard.

- 2) Take out the A/C filter element and clean it with compressed air. If the filter element is damaged, replace it.

- 3) Install the filter element and housing.

1.5.4 Checking the transmission fluid level (If equipped)

This item is performed every 50 hours or weekly, whichever comes first.

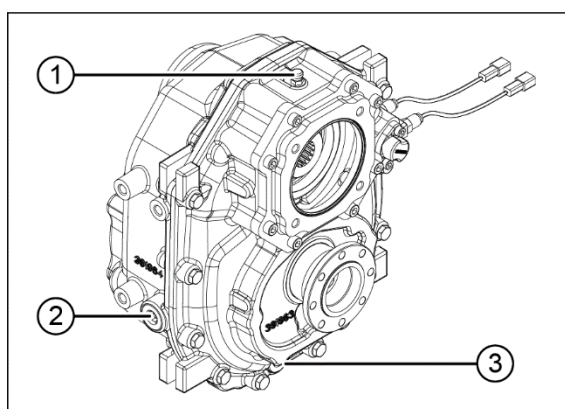

- 1 Breather
- 2 Fill oil plug
- 3 Oil drain plug

1. Stop the engine, park the machine on a level ground, set the gear selector to N gear, activate the electronic parking brake, and chock the tire to prevent the machine from moving.
2. Clean the transfer case filling port and the area around it.
3. Unscrew the plug on the filling port, observe the oil level, and if the oil is lower than the lower edge of the filling port, fill the transfer case with oil until oil reaches the lower edge of the filling port.



! **CAUTION:** High/low transfer case fluid level will cause damage to the transfer case. Please keep the transfer case fluid level in the correct position.

! **CAUTION:** During the process of checking the transfer case fluid level and replacing the transfer case fluid, pay attention to cleanliness to avoid entering of dirt into the transfer case system and damaging the transfer case.

1.6 Every 250 hours

1.6.1 Replacing cab A/C filter

This item is performed every 250 hours or quarterly, whichever comes first.

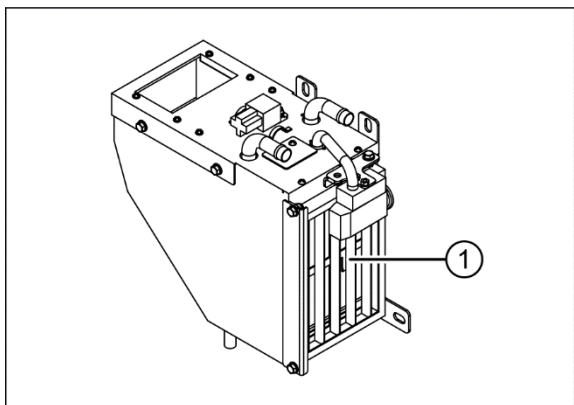

- 1) Remove the rocker switch panel on the dashboard.
- 2) Take out the A/C filter element and replace with a new filter element.
- 3) Install the panel.

1.6.2 Check the drive axle final drive and wheel reducer oil level

This item is performed every 250 hours or quarterly, whichever comes first.

! **CAUTION:** Before the operation, the engine shall be stopped, the vehicle shall be parked on a level surface, activate the electronic parking brake, and the tire shall be blocked to prevent the machine from moving.

! **CAUTION:** To discharge, fill and check the oil level, the drive axle must be horizontal and mounted on the vehicle.

Check the reducer oil level every 250 hours or quarterly. Improper reducer oil level will lead to equipment performance degradation, and continuous use will lead to component damage.

Check the oil level of the final drive

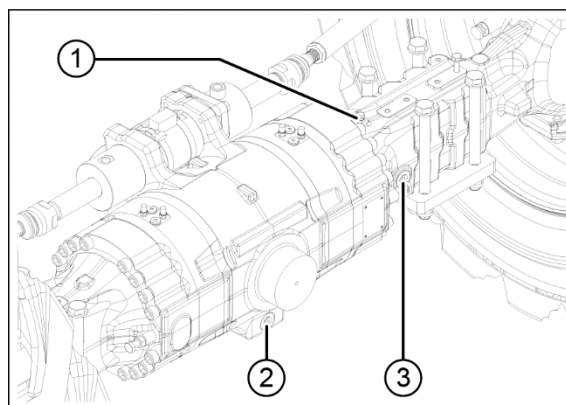

- 1 Breather
- 2 Oil drain plug
- 3 Oil filler plug



- 1) Carefully clean the breather and surrounding area.
- 2) Check the oil level: remove the oil filler plug and check whether the oil level is at the lower edge of the filler. Otherwise, add oil and tighten the plug.

Check drive axle wheel reducer oil

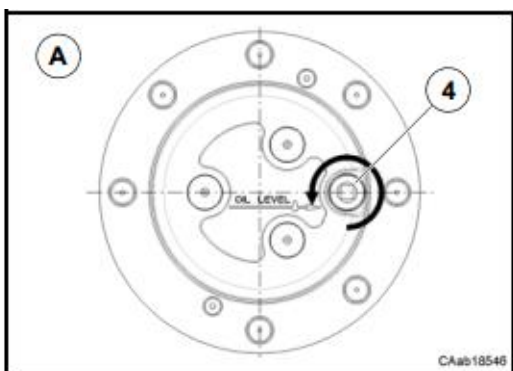

1. Turn the wheel so that the plug (4) is in the highest position and unscrew it to some extent to release the possible pressure.
2. Turn the wheel so that the plug (4) is in the horizontal position, remove the plug to check whether the oil level is at the lower edge of the oil filler , otherwise add oil and tighten the plug.

1.6.3 Checking transfer case oil level

This item is performed every 250 hours or quarterly, whichever comes first.

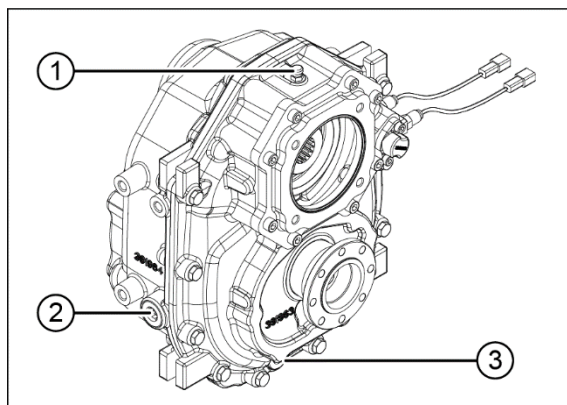

- 1 Breather
- 2 Fill oil plug
- 3 Oil drain plug

- 1) Stop the engine, park the machine on a level ground, set the gear selector to N gear, activate the electronic parking brake, and chock the tire to prevent the machine from moving.
- 2) Oil level inspection: remove the oil filler plug and check whether the oil level is on the lower edge of the filler, otherwise add oil.
- 3) Tighten the plug.

1.6.4 Lubricating boom slider

Carry it out every 10 hours for the first 50 hours and every 250 hours thereafter.

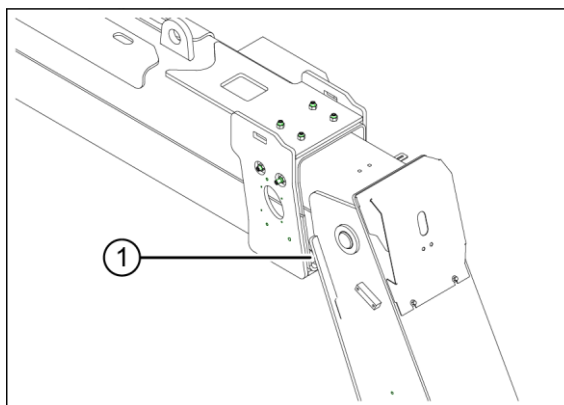



- 1) Raise the outrigger (If equipped with outrigger).
- 2) Extend the boom as much as possible.
- 3) Apply grease evenly around the boom with a brush (molybdenum disulfide is recommended).
- 4) Remove excess grease and retract the boom.

1.6.5 Checking hydraulic oil

This item is performed every 250 hours or quarterly, whichever comes first.

Collect a hydraulic oil sample, place it in a transparent container, and visually inspect the hydraulic oil as follows:

- Color: the oil shall be transparent and appear in light honey color.
- Appearance: the oil shall be clear, not cloudy, and free of particles, foreign matters or other contaminants.
- Check the hydraulic oil through the smell (the heat can be smelled, but there is no "burnt" smell) or the friction between the fingers (there shall be a sticky feeling, no rough feeling of any particles). If all hydraulic oil pass the above inspection, continue to service at predetermined intervals. If the hydraulic oil does not comply with any of the above inspections,

the hydraulic oil must be tested or replaced.

- 1) Replacement or testing of hydraulic oil is critical to the performance and service life of the equipment. Contaminated hydraulic oil may affect equipment performance, and continuous use will cause equipment damage. For harsh working environment, the inspection should be carried out more frequently.
- 2) Before replacing the hydraulic oil, the oil stain separator can be used to test whether it is necessary.
- 3) If the hydraulic oil has not been replaced for two years, it shall be tested quarterly. If it fails to pass the test, replace the hydraulic oil.

Note: when replacing the hydraulic oil, it is recommended to replace all hydraulic filters at the same time.

1.7 Every 500 hours

1.7.1 Replacing engine oil and oil filter

First 50 hours, and then change it every 500 hours or every half a year, whichever comes first.



**Do not work on the running engine!
No smoking and open fire!**



Be careful when handling high temperature engine oil. Risk of burning!

 When working on the oil system, pay attention to the cleanliness of the outer surface. Carefully clean all areas involved.

Dry the wet parts with compressed air.

 Please abide by the oil safety provisions and local regulations. Dispose of spilled oil and filter elements as specified. Ensure that waste oil doesn't drip to the ground.

Draining engine oil (Kubota V3307)

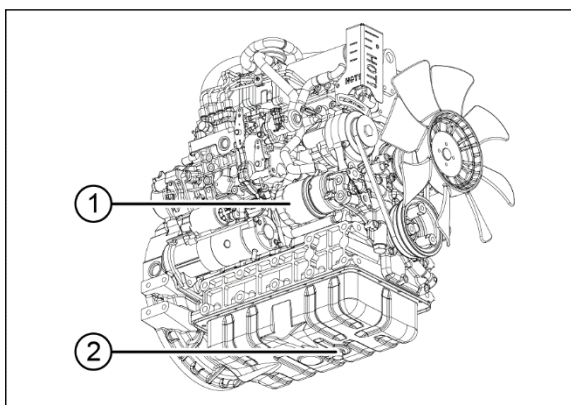

1 Oil filter
2 Oil drain plug

- 1) Warm up the engine.
- 2) Place the engine horizontally.
- 3) Shut down the engine.
- 4) Place a container under the oil drain plug.
- 5) Unscrew the oil drain plug and drain the old oil.
- 6) Install a new seal ring on the oil drain plug, screw the oil drain plug in and tighten it.

Replacing the oil filter

 **CAUTION:** Each time the oil is changed, the oil filter element should also be replaced.

Kubota V3307:

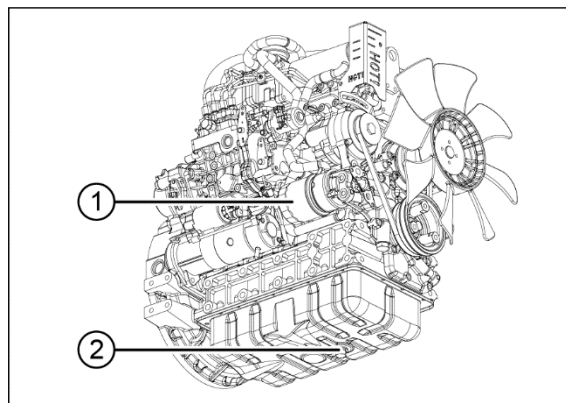

1 Oil filter
2 Oil drain plug

- 1) Clean the area near the oil filter mounting seat.
- 2) Remove the oil filter with the belt wrench.
- 3) Clean the gasket contact surface of the mounting with a clean cloth.
- 4) Apply a clean coat of oil to the new oil filter O-ring.
- 5) Screw in the new oil filter until the O-ring contacts the oil filter base and rotate the oil filter for 3/4 full turns.

Kubota V3307:

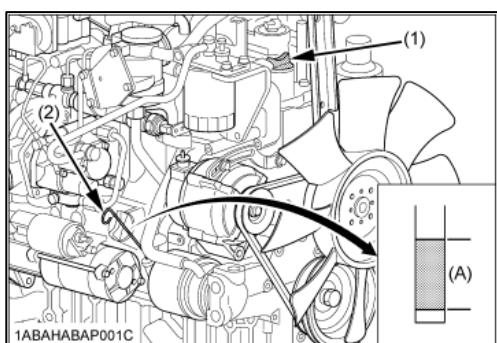

1 Oil filler plug

2 Oil dipstick

- 1) Add oil through the oil filter.
- 2) Wait a few minutes for oil to flow into the oil pan.
- 3) Warm up the engine and run it at low speed for 3 minutes to check the drain plug and the filter for leakage.
- 4) Turn off the engine, wait a few minutes, check the oil level and refill if necessary.

1.7.2 Replacing primary fuel filter element

Replace every 500 hours or every six months, whichever comes first.

⚠ Engine must be turned off!

No smoking and open fire!

Be careful when handling hot fuel!

⚠ Do not loosen the fuel injection pipeline or high pressure fuel pipeline while the engine is running.

⚠ Carefully clean all areas involved.

Dry the wet parts with compressed air.

⚠ Please observe safety regulations on fuel and relevant local laws and regulations.

Dispose of spilled fuel and filter elements according to regulations. Fuel must not leak to the ground.

⚠ After the operation on the fuel system is completed, bleed the system, conduct a trial run and check the tightness.

⚠ Explosion and fire hazard. Engine fuel is combustible. Check the location of the machine. This step shall be performed in open areas away from heaters, sparks, flames, and burning tobacco. A conforming fire extinguisher should be placed in an easily accessible place.

⚠ The secondary fuel filter element must be replaced at the same time as the primary fuel filter element.

Kubota V3307:

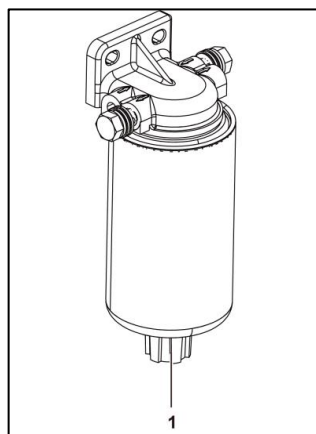

1 Drain valve



- 1) Clean the mounting and the area around the filter.
- 2) Place the container under the drain valve.
- 3) Open the drain valve to drain the filter. Allow the liquid to flow into the container.
- 4) Remove the fuel filter with the belt wrench.
- 5) Apply a thin layer of oil to the new filter seal ring.
- 6) Reinstall the fuel filter and rotate it 3/4 of a full turn after the O-ring touches the filter base.
- 7) Take out the container and dispose the fuel in accordance with local regulations.
- 8) Bleed the fuel system.

1.7.3 Replacing secondary fuel filter

Kubota V3307:

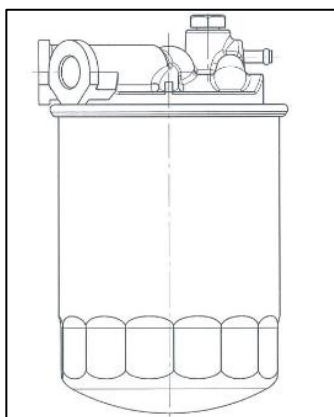

- 1) Remove the fuel filter with the belt wrench.
- 2) Contain the diesel fuel drained.
- 3) Clean the sealing surface of the filter

holder with a clean fiber-free wiper.

- 4) Apply a thin layer of diesel to the seal ring of the new filter.
- 5) Screw in a new filter manually until seal fit and tighten it.
- 6) Exhaust the fuel system.

1.7.4 Bleeding the fuel system



To avoid personal injury:

Do not bleed a hot engine, as this can cause fuel to spill on the hot exhaust manifold and cause fire hazard.

The fuel system needs to be bled under the following conditions:

- The fuel tank is empty or some fuel is discharged from the fuel tank.
- Disconnect the low-pressure fuel pipe.
- The low-pressure fuel system is leaking.
- Replace the fuel filter.
- Engine not used for a long time.

Kubota V3307:

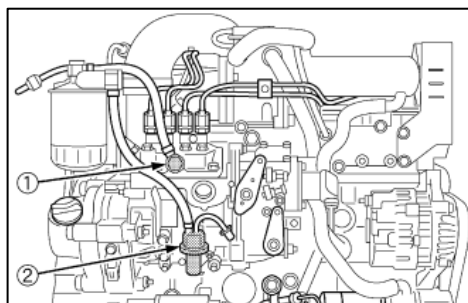

- 1) Turn on the exhaust bolt on the top of fuel jet pump.
- 2) Start the engine and run for 10 seconds.



- 3) Turn off the exhaust bolt on the top of fuel jet pump.

1.7.5 Replacing crankcase breather filter element (If equipped)

! CAUTION: Be sure to shut down the engine before performing any maintenance or repair work.

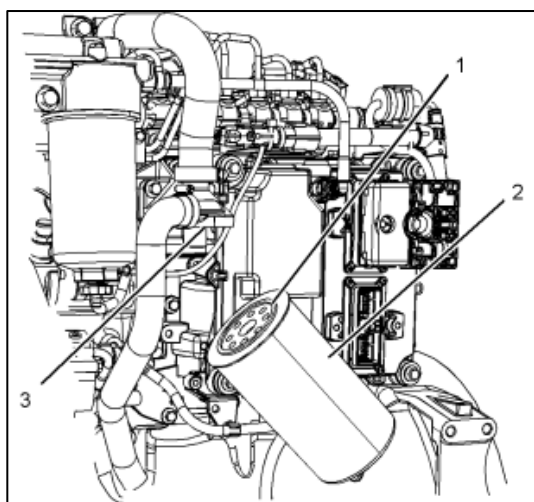

- 1) Place a suitable container under filter (2).
- 2) Clean the outside of the filter and remove the filter with a belt wrench.
- 3) Lubricate the new filter O-ring (1) with clean engine oil.
- 4) Install a new filter. Screw in the filter until the O-ring contacts the base (3). Tighten the filter by hand for 3/4 full turn.
- 5) Take away the container. Discard old filter and any surplus oil in accordance with local regulations.

1.7.6 Checking belt

In order to obtain the highest performance

of the engine, check the belt for wear and crack. If the belt is worn or damaged, replace the belt.

Check the belt for cracks, splits, wear, grease, misalignment of the wire core and signs of liquid contamination.

Kubota V3307:

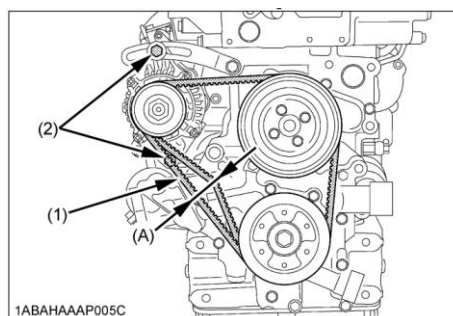

1. Fan belt
2. Bolt and nut

- 1) Stop the engine.
- 2) Apply moderate thumb pressure to belt between the pulleys.
- 3) If tension is incorrect, loosen the alternator mounting bolts and, using a lever placed between the alternator and the engine block, pull the alternator out until the deflection of the belt falls within acceptable limits.

Replace fan belt if it is damaged.

Proper fan belt tension	A deflection when the belt is pressed in the middle of span.
V3307: 10 to 12mm	under load of 10 kg



1.7.7 Replacing filter element of hydraulic system

Replace every 500 hours or six months, whichever comes first.

It is necessary to change the hydraulic return filter element and hydraulic high-pressure filter element every 500 hours. Regular changing of filters is necessary for good machine performance and long service life. Dirty or blocked filter may cause the hydraulic component performance degradation, and continuous use may cause component damage. Extreme operating conditions require increased filter replacement.

Retract the boom and park the machine on a level ground, shut down the engine.

Replace the hydraulic oil tank return filter element

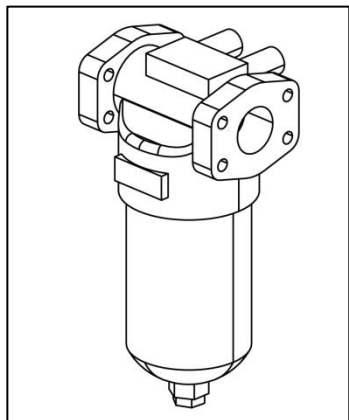

- 1) Shut down the engine and release the pressure in the hydraulic system.

- 2) Place a suitable container under the filter.
- 3) Remove the nut at the bottom of the filter cover with a wrench and remove the filter cover.
- 4) Remove the filter element from the filter cover.
- 5) Check the seal of the filter cover and replace it if necessary.
- 6) Install a new filter element and tighten it.
- 7) Scrub off any oil droplets splashed during installation.
- 8) Inspect the filter housing and associated elements to make sure there is no leakage.

Replace high-pressure filter element

Replace every 500 hours or six months, whichever comes first.

Regular filter replacement is necessary for good machine performance and long service life. Dirty or blocked filter may cause the hydraulic component performance degradation, and continuous use may cause component damage. Extreme operating conditions require increased filter replacement.

Retract the boom and park the machine on a level ground, shut down the engine.

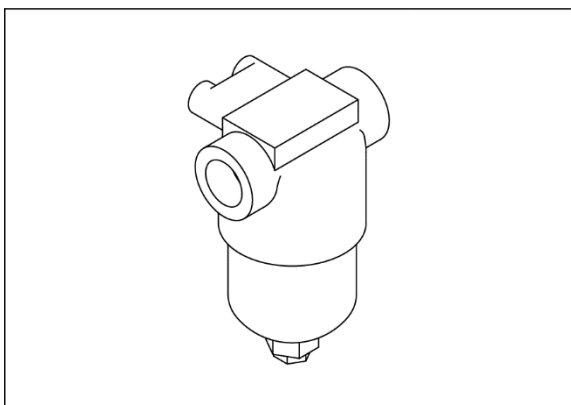

- 1) Shut down the engine and release the pressure in the hydraulic system.
- 2) Place a suitable container under the filter.
- 3) Remove the nut at the bottom of the filter cover with a wrench and remove the filter cover.
- 4) Remove the filter element from the filter cover.
- 5) Check the seal of the filter cover and replace it if necessary.
- 6) Install a new high-pressure filter element and tighten it.
- 7) Scrub off any oil droplets splashed during installation.
- 8) Inspect the filter housing and associated elements to make sure there is no leakage.

1.8 Every 1000 hours

1.8.1 Replacing air filter element

Check the dust discharge valve every day, replace the cracked and deformed dust

discharge valve, and clean the dust in it.

Check the maintenance indicator of the air cleaner (if applicable).

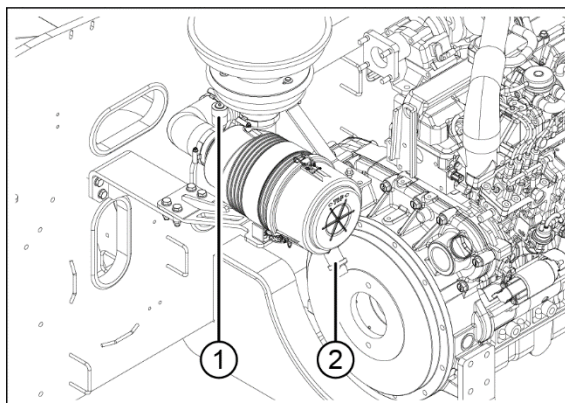

1. Electronic differential pressure sensor
2. Dust discharge valve

When the intake resistance reaches the maximum intake resistance of the engine, the main filter element shall be cleaned.



Perform this step when the engine is turned off.

Clean the air cleaner primary element

Clean the main filter element every 250 hours or when the air filter indicator is red. After cleaning, press the mechanical differential pressure alarm reset button.

The main filter element needs to be replaced only when the air cleaner primary element is cleaned 5-6 times or the regular maintenance time is reached.

When replacing the main filter element, replace the safety filter element together.

- 1) Turn off the engine and open the hood.



- 2) Remove the A/C filter element cover.
- 3) The radial sealed main filter element is tightly installed on the air outlet pipe. The removal of the filter element has a little resistance, so it is recommended to rotate the filter element while pulling it out to avoid knocking the housing and the filter element.

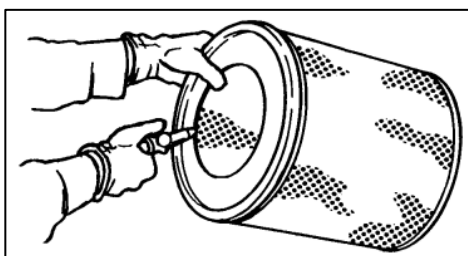

- 4) Clean the filter element from the inside out with a low pressure compressed air (up to 207Kpa) at least 30mm from the filter element.
- 5) When replacing the safety filter element, clean the inside of the air outlet pipe with a clean damp cloth and check the sealing surface for damage. Avoid the air inlet of the engine (i.e. the air cleaner outlet) exposed as much as possible. If there is no proper safety filter element, you can replace one immediately.
- 6) Check whether new filter elements are in good condition, especially on the sealing surface and clean sides, and avoid installing damaged filter element. Do not

wipe the sealing surface because the surface of the filter element is coated with a layer of lubricant to facilitate easier installation of the filter element.

- 7) If the safety filter element has just been replaced, it is necessary to confirm whether the safety filter element is installed correctly before the installation of the main filter element, then push the edge of the filter element by hand, carefully install the main filter element, and confirm that the main filter element is fully installed in the housing. The main filter element cannot be pushed in by the pressure of the end cap, which will damage the housing and the buckle. If the end cap cannot be installed in place due to the filter element, remove the end cap and continue to push in the main filter element to install the main filter element in place.
- 8) Check all fasteners including hoops, clamps, nuts and connections for tightening, check the pipeline for leaks, and repair them. Any leakage will cause dust to bypass the air cleaner and enter the engine directly, and finally reset the alarm indicator.



1.8.2 Replacing hydraulic oil tank breather

Park the machine on level ground and turn off the engine.

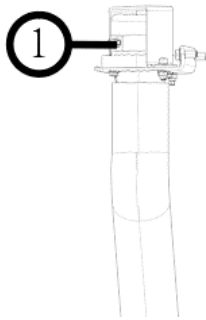

- 1) Remove the old breather and replace it with a new one.

1.8.3 Replacing the filter

First maintenance after 250 h, then maintain the vehicle every 1000 h.

- 1) Remove the filter and seal.
- 2) Clean the gasket contact surface of the mounting with a clean cloth.
- 3) Apply a clean layer of lubricating oil to the O-ring of the new filter.
- 4) Reinstall the new filter on the mounting.

Adding the transfer case oil

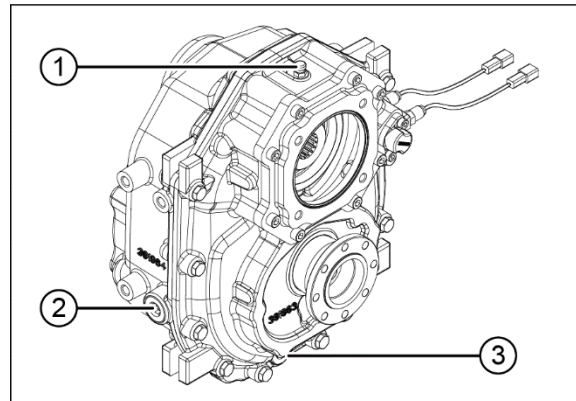

- 1 Breather
- 2 Fill oil plug
- 3 Oil drain plug

- 1) Add the lubricating oil through the oil filler to the lower edge of the oil filler, wait for 5 minutes, check the oil level again, and add it if necessary.
- 2) Install the upper oil filler plug.

1.8.4 Replacing transfer case oil

First maintenance after 250 h, then maintain the vehicle every 1000 h.

Stop the engine, park the machine on a level ground, set the gear selector to N gear, shut down the engine, activate the electronic parking brake, and chock the tire to prevent the machine from moving.

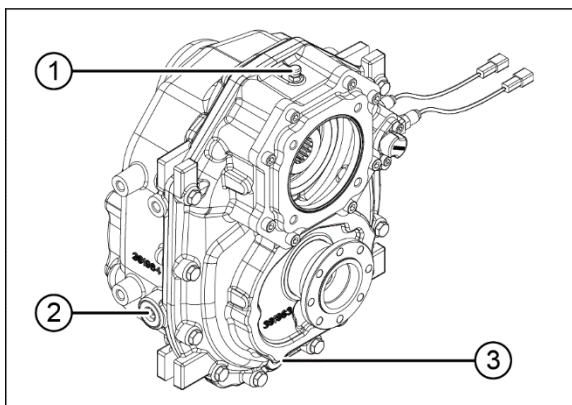

- 1 Breather
- 2 Fill oil plug
- 3 Oil drain plug

- 1) Place a suitable container under the drain plug, remove the oil filler plug and drain plug, drain all oil, clean and install the plug.
- 2) Add the lubricating oil through the oil filler to the lower edge of the oil filler, wait for 5 minutes, check the oil level again, and add it if necessary.
- 3) Install the oil filler plug.

1.9 Every 1500 hours

1.9.1 Replacing the drive axle reducer oil

The first maintenance is 150h, and then the maintenance is carried out every 1500h.

Stop the engine, park the machine on a level ground, set the gear selector to N gear, activate the electronic parking brake, and chock the tire to prevent the machine from moving.

Replacing the drive axle final drive oil

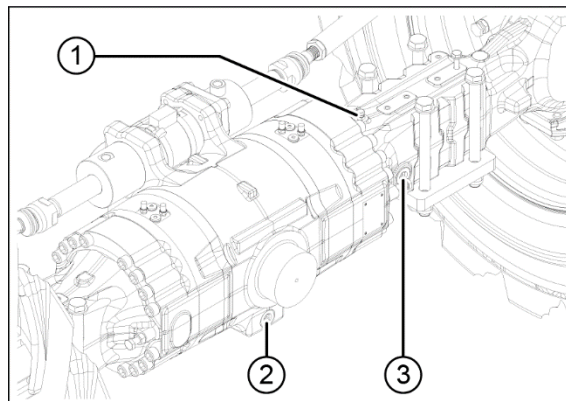

- 1 Breather
- 2. Oil drain plug
- 3 Oil filler plug

- 1) Place a suitable container under the drain plug, first remove the oil filler plug and then remove the drain plug. Drain all oil. Install and tighten the drain plug.
- 2) Add the specified drive axle oil to the lower edge of the oil filler plug hole. Wait for 5 minutes, then check the oil level and add it to the specified level if necessary. Install and tighten the oil filler plug.

Replacing the drive axle wheel reducer oil

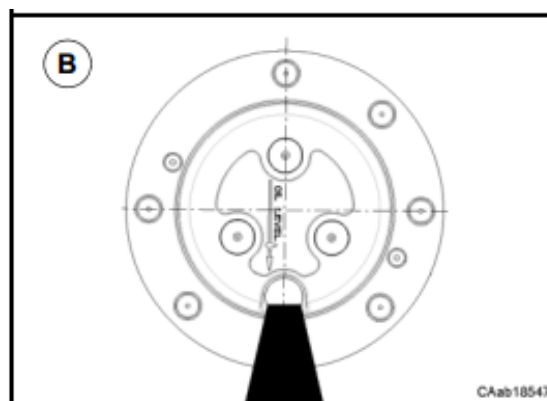

1. Turn the wheel so that the plug is in the highest position and unscrew it to some



extent to release the possible pressure.

2. Rotate the wheel so that the drain plug is in the lowest position and place a suitable container underneath. Remove the screw plug and drain oil.

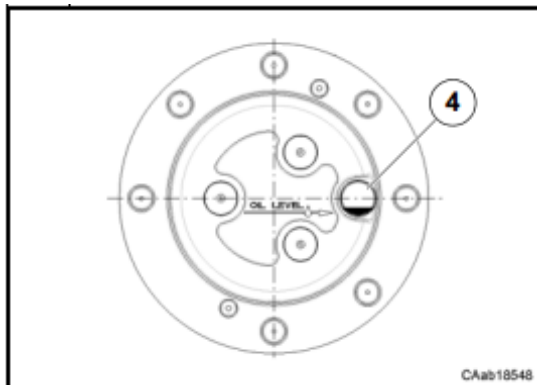

3. Turn the wheel so that the plug is in a horizontal position. Add the specified oil to the lower edge of the filling hole.
4. Tighten the plug.

1.10 Every 2000 hours

1.10.1 Replacing coolant

The coolant in the cooling system shall be completely replaced every 2000 working hours or two years (whichever comes first). Before that, if the coolant is contaminated, the engine is overheated or the radiator is foamed, it should be replaced in advance.

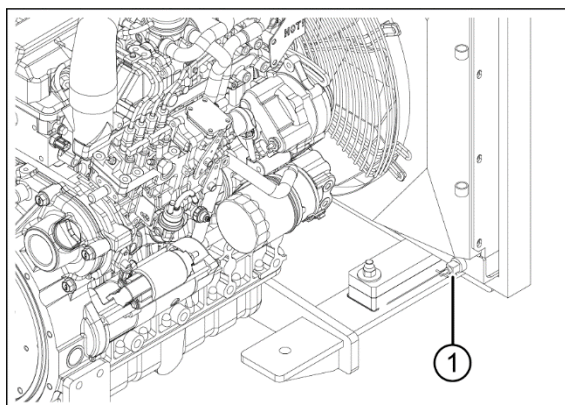

1. Outlet of radiator coolant

- 1) Close the engine and allow it to cool.
- 2) Remove the coolant filler cap from radiator.
- 3) Open the water drain valve of the radiator and the drain valve of the engine coolant as well as the coolant drain valve of the transmission, discharge the coolant and hold it with a container.
- 4) After the engine and transmission coolant is drained thoroughly, close the drain valve (if equipped) for radiator, engine and transmission.
- 5) Check all water pipes and clamps of cooling system for damage and replace them if necessary. Check the water radiator for leakage, damage and dirt accumulation, and clean and repair it as required.
- 6) Fill slowly by the filler until the maximum allowable level of the Radiator.
- 7) Install the coolant filler cap.



- 8) Run the engine at idle speed, check for leakage and level, and refill if necessary.

1.10.2 Replacing hydraulic oil

It is required to be replaced every 2000 h or every two years, whichever comes first.

Before replacing the hydraulic oil, a hydraulic oil test can be performed to confirm whether it is necessary to replace it. If the hydraulic oil is not replaced during the 2000 h test, the hydraulic oil is tested quarterly.

Replace the hydraulic oil until the test fails.

! CAUTION: The hydraulic suction filter should be replaced when the hydraulic oil is replaced.

- 1) Park the vehicle on the level ground so that the vehicle is in the storage position.
- 2) Close the ball valve located on the hydraulic oil tank (if equipped with ball valve).

! Danger of component damage. Do not start the engine when the hydraulic oil tank ball valve is closed, otherwise the components will be damaged. If the ball valve is turned off, take the key from the key switch and hang a warning sign on the device.

! Danger of physical injury. The

splashed hot oil can penetrate and burn the skin.

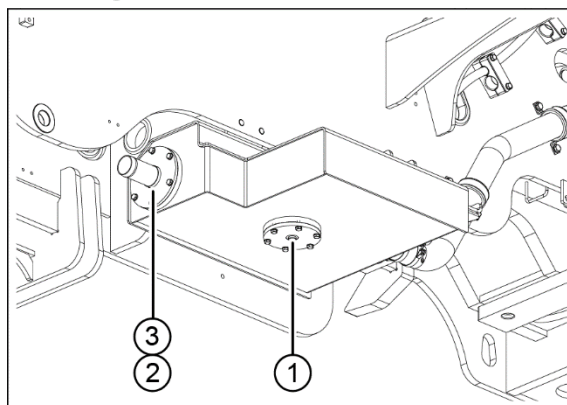
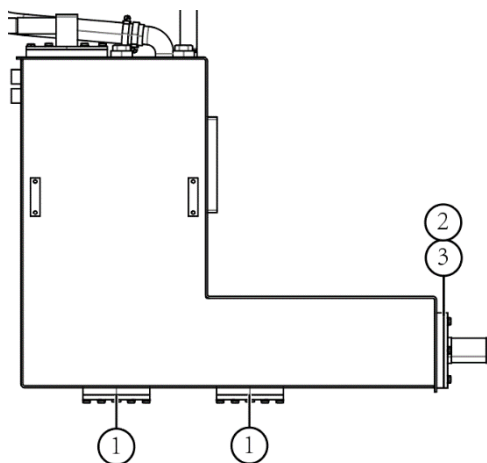

- 1 Drain plug
2 Connecting bolt of suction flange and tank
3 Suction filter

- 3) Remove the drain plug from the hydraulic oil tank.
- 4) Drain the hydraulic oil from the hydraulic oil tank completely into a suitable container. To speed up the oil drain, open the oil tank filler cap.
- 5) Remove the suction filter from the hydraulic oil tank.
- 6) Flush the inside of the hydraulic oil tank with a mild solvent. (Clean one side with



chemical cleaning agent first. After drying, rinse with clean hydraulic oil to release cleaning oil.)

- 7) Clean the foreign matter absorbed by the ring magnet.
- 8) Install a new suction filter.
- 9) Install the upper drain plug.
- 10) Add an appropriate amount of hydraulic oil to the hydraulic oil tank. No overflow is allowed. Wipe and wash off Hydraulic oil that may splash out.
- 11) Open the Ball valve on the Hydraulic oil tank (if equipped with Ball valve).

 **Danger of component damage, make sure to open the Hydraulic oil tank ball valve and fill the pump with oil after installing the Hydraulic oil tank.**

 **CAUTION: When installing drain plug and filter, please be sure to use pipe thread sealant.**

- 12) Check the function of all machines and check for oil leakage through one full cycle.
- 13) After a working cycle, recheck the level of the fuel tank and add an appropriate amount of hydraulic oil. It is strictly prohibited for the oil to overflow.



1.11 Appendix

1.11.1 Maintenance instructions

1) General instructions

Before starting the Telescopic handler, ensure that the area is well ventilated.

Wear suitable clothes and avoid jewelry and loose and comfortable clothes. If necessary, tie and protect your hair.

If necessary, stop the engine and remove the ignition key.

Read the operation manual carefully.

Carry out all repairs immediately, even if the relevant repairs are minor.

Repair all leaks immediately, even if the relevant leaks are small.

Ensure that old materials and spare parts are handled in a completely safe and ecological manner.

Be careful of the danger of burning and splashing (exhaust, radiator, internal combustion engine, etc.).

2) Lubricating oil and fuel

Use the recommended lubricating oil (never use contaminated lubricating oil).

Never fill the primary fuel filter element while the engine is running.

Fill the primary fuel filter element only in the area specified for this purpose.

Never fill the fuel tank to the upper limit.

When the fuel tank is open or being filled, do not smoke or use flames around the telescopic handler.

3) Hydraulic system

Do not attempt to loosen joints, hose or any hydraulic component while the circuit is under pressure.



Balance valve: It is dangerous to change and remove balance valve or safety valves that may be installed on telescopic handler cylinder. These operations can only be performed by approved technicians.



Hydraulic accumulator: These hydraulic accumulator that may be installed on the



telescopic handler are pressurized devices. Disassembling these accumulators and their piping systems is a dangerous operation and must be performed by an approved technician.

Release the accumulator pressure of the brake system before service: park the machine on solid level ground, retract the boom to the stowed position, stop the engine, and place pads under the wheels. Repeatedly press and release the travel brake pedal (foot brake);

4) Electrical system

Never Short circuit the starter to start the Engine. If the forward / N gear / reverse selector is not in the position of N gear and the parking brake is not engaged, the Telescopic handler may move abruptly.

Do not touch the battery with metal objects.

Disconnect the battery before operating the circuit

5) Welding operation

Disconnect the battery before performing any welding operations on the telescopic handler.

Do not perform welding work on the assembled tire, which will increase the pressure and cause the tire to explode.

Disconnect the electronic control unit to avoid irreparable damage to electronic components.

6) Cleaning vehicle

Close and lock all doors, windows, etc.

Avoid contacting with joints, electrical components and connectors during cleaning.

If necessary, prevent water, steam or detergent from entering vulnerable parts, especially electrical components.



1.11.2 Selection of oils

Type	Recommended types and standards	Oil parts
Engine oil API CH-4	Lowest ambient temp. $\geq -10^{\circ}$, SAE 15W-40	Engine (EU Stage III engines)
	Lowest ambient temp. $< -10^{\circ}$, SAE 10W-30	
Engine oil API CJ-4	Lowest ambient temp. $\geq -10^{\circ}$, SAE 15W-40	Engine (EU Stage V engines)
	Lowest ambient temp. $< -10^{\circ}$, SAE 10W-30	
Gear oil	API GL-4, SAE 75W or API GL-4, SAE 80W-90	Axle
	Mobil fluid 424	
Gear oil	API GL-4, SAE 75W	Transfer case
	Mobil fluid 424	
Gear oil	L-CKD 220	Slewing reducer
Hydraulic oil	Minimum temp. $> -25^{\circ}\text{C}$, L-HV46 low temp. hydraulic oil	Hydraulic oil tank
	$-40^{\circ}\text{C} < \text{minimum temp.} \leq -25^{\circ}\text{C}$, L-HS32 ultra-low temp. hydraulic oil	
	Minimum air temp. $\leq -40^{\circ}\text{C}$, 10 aviation hydraulic fluid	
Fuel	Ambient temp. $\geq 4^{\circ}\text{C}$ No. 0 Light diesel fuel	Fuel tank EN590 and ASTM D975 ULSD
	Ambient temp. $\geq -5^{\circ}\text{C}$ -No. 10 Light diesel fuel	
	Ambient temp. $\geq -14^{\circ}\text{C}$ -No. 20 Light diesel fuel	
	Ambient temp. $\geq -29^{\circ}\text{C}$ -No. 35 Light diesel fuel	
Grease	No. 2 or No. 3 lithium-based grease	Working device hinge point axis pin
	Molybdenum disulfide	
Antifreeze	Antifreeze -25°C ethylene glycol content 40%	Cooling system
	Antifreeze -35°C ethylene glycol content 50%	
	Antifreeze -45°C ethylene glycol content 60%	
Air conditioner	R134a	



1.11.3 Maintenance items

Maintenance item	Operation content	Maintenance level						
		Every day	Weekly	Quarterly	Every six months	Every year	Two year	Four year
		8h	50h	250h	500h	1000h	2000h	4000h
Engine	Check engine oil level	•						
	Check the coolant level	•						
	Check the fuel level	•						
	Check the primary fuel filter	•						
	Clean radiator core		•					
	Replace engine oil and filter				•			
	Discharge the water and impurities from the primary fuel filter	•						
	Replace the secondary fuel filter element				•			
	Replace the primary fuel filter element				•			
	Replace crankcase breather filter element (if equipped)				•			
	Clean the fuel tank					•		
	Replace air cleaner primary element					•		
	Replace air cleaner safety filter element					•		
	Replace the coolant						•	
	Tighten cooling pipe clamp			•				
	Tighten intake pipe hose			•				
	Check air cleaner maintenance indicator		•					
	Clean air cleaner dust cup	•						
	Check generator and fan belt tension			•				
Check engine fan clearance and drive Belt			•					
Check electrical components and electronic control system wiring harness		•						
Front axle	Check the final drive and the wheel reducer oil level			•				



Maintenance item	Operation content	Maintenance level						
		Every day	Weekly	Quarterly	Every six months	Every year	Two year	Four year
		8h	50h	250h	500h	1000h	2000h	4000h
Front axle	Replace the final drive lubricating oil (at least once a year)	The first maintenance is 150h, and then the maintenance is carried out every 1500h.						
	Replace wheel reducer lubricating oil (at least once a year)	The first maintenance is 150h, and then the maintenance is carried out every 1500h.						
	Check tire pressure	•						
	Check the fixing of wheel nut	•						
	Clean oil breather			•				
	Rear axle	Check the final drive and the wheel reducer oil level			•			
Replace the final drive lubricating oil (at least once a year)		The first maintenance is 150h, and then the maintenance is carried out every 1500h.						
Replace wheel reducer lubricating oil (at least once a year)		The first maintenance is 150h, and then the maintenance is carried out every 1500h.						
Check tire pressure		•						
Check the fixing of wheel nut		•						
Clean oil breather				•				
Drive shaft	Retighten the propeller shaft bolt		•					
	Check the connection and wear of propeller shaft		•					
	Universal joint lubrication		•					
	Propeller shaft lubrication		•					
Cab	Check the action of the wiper	•						
	Clean the cab A/C filter		•					
	Replace the cab A/C filter			•				
	Check the washer fluid level		•					
	Check whether the accelerator pedal, brake pedal, and combined operation joystick are flexible	•						
	Check the seat belt	•						
	Check the coolant level and	•						



Maintenance item	Operation content	Maintenance level						
		Every day	Weekly	Quarterly	Every six months	Every year	Two year	Four year
		8h	50h	250h	500h	1000h	2000h	4000h
	the fuel level of the water heater in the cab (if equipped)							
Boom	Check boom padding block wear				•			
	Boom and padding block lubrication			•				
Electrical system	Check the operation of electrical system (signal lamps, headlamps, height indicator lamps, wiper, heating and ventilation devices)			•				
	Check the fixing of the battery terminal, and apply grease to the electrodes					•		
	Check the working condition of the instrument	•						
Steering system	Check the function of the steering system	•						
Hydraulic system	Check hydraulic oil level	•						
	Replace return filter element				•			
	Replace the high-pressure filter element (if equipped)				•			
	Replace the hydraulic oil tank breather					•		
	Check the working conditions of the hose and cylinder					•		
	Replace the brake accumulator filter (if equipped)					•		
	Clean hydraulic oil tank						•	
	Replace hydraulic oil						•	
	Replace suction filter						•	
	Check hydraulic circuit pressure						•	
	Check hydraulic circuit output						•	
Brake	Check brake system pressure					•		



Maintenance Manual of Telescopic Handler

Maintenance item	Operation content	Maintenance level						
		Every day	Weekly	Quarterly	Every six months	Every year	Two year	Four year
		8h	50h	250h	500h	1000h	2000h	4000h
system	Adjust brake					•		
	Check brake pads and brake discs for wear							•
	Check the clearance of the front and rear axle reducers							•
Complete vehicle	Check the fork wear				•			
	Fill each propeller shaft with grease		•					



1.11.4 Engine DTC

Kubota V3307:

DTC	SPN	FMI	Detection item	DTC set parameter
Oil Pressure Error	100	1	Oil pressure switch	Despite rpm, oil pressure switch is on
Engine overheat	110	0	Overheat of engine water temp.	Engine water temp. ≥ 110 °C
Water temp. sensor: High	110	3	Open circuit of sensor / harness, + B short circuit	Voltage of coolant temp. sensor is 4.9 V or above
Water temp. sensor: Low	110	4	Ground short circuit of sensor / harness	Voltage of coolant temp. sensor is 0.1 V or less
Battery voltage: High	158	3	Open circuit, short circuit, or damage of harness. Failure of battery	ECU recognition of battery voltage is above 18 V.
Engine overrun	190	0	Engine speed exceeds threshold speed	Engine speed $> (1.15 \times \text{speed})$ min-1 (rpm)
Sensor supply voltage 1: Low	3509	4	Sensor supply voltage 1	Voltage to sensor is below 4.00 V
Actuator Abnormal	523771	2	Open circuit, short circuit, or damage of harness.	Actuator current $> 3.0A$ or $< 80mA$
Engine Speed Sensor Abnormal	523772	2	Open circuit, short circuit, or damage of harness.	Engine speed = 0 min-1 (rpm) and alternator L terminal has voltage, after engine start.
Starter error	523736	2	Starter running time exceed threshold time	Starter running time is above 12 sec
Alternator L, terminal Abnormal	523737	2	Open circuit, short circuit, or damage of harness	Alternator L terminal has voltage while engine 0 rpm (after key on)
Charging failure	523738	2	Open circuit, short circuit, or damage of harness	Alternator L terminal is 0V while engine is running
Speed sensor pulse abnormal	523740	2	Engine speed sensor pulse abnormal	Less than correct gear tooth number
CAN Communication Abnormal	523774	2	CAN bus	CAN bus off
Emergency stop	-	-	Emergency stop switch	Emergency stop CAN signal into ECU
+B disconnection	523749	2	+B disconnection	+B disconnection before key off



1.11.5 Lubrication points indication

Lubrication point of the whole machine:

- 1) If work time is less than 50 h per week, then maintain it once a week.
- 2) If work continuously for a long time, the lubrication period is reduced to every 10 hours or every day.

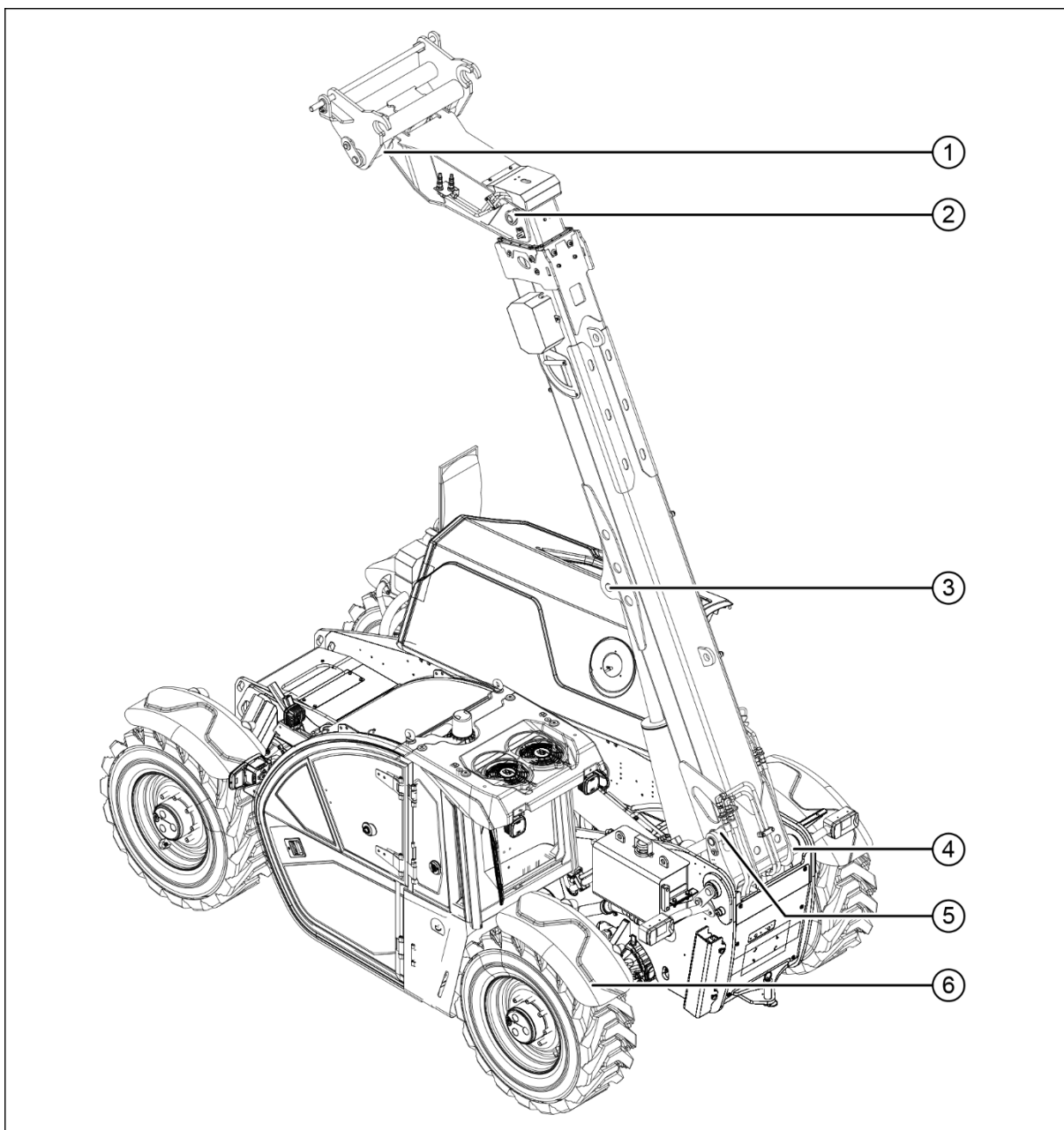



No.	Location	Clockwise rotation joystick
1	Rotating lubrication point of auxiliary rack	2
2	Elevated flat cylinder lubrication point	2
3	Luffing cylinder lubrication point	2
4	Boom hinge lubrication point	2
5	Lower leveling cylinder lubrication point	2
6	Tire steering lubrication point	4



1.11.6 Hydraulic schematic diagram

Hydraulic schematic diagram

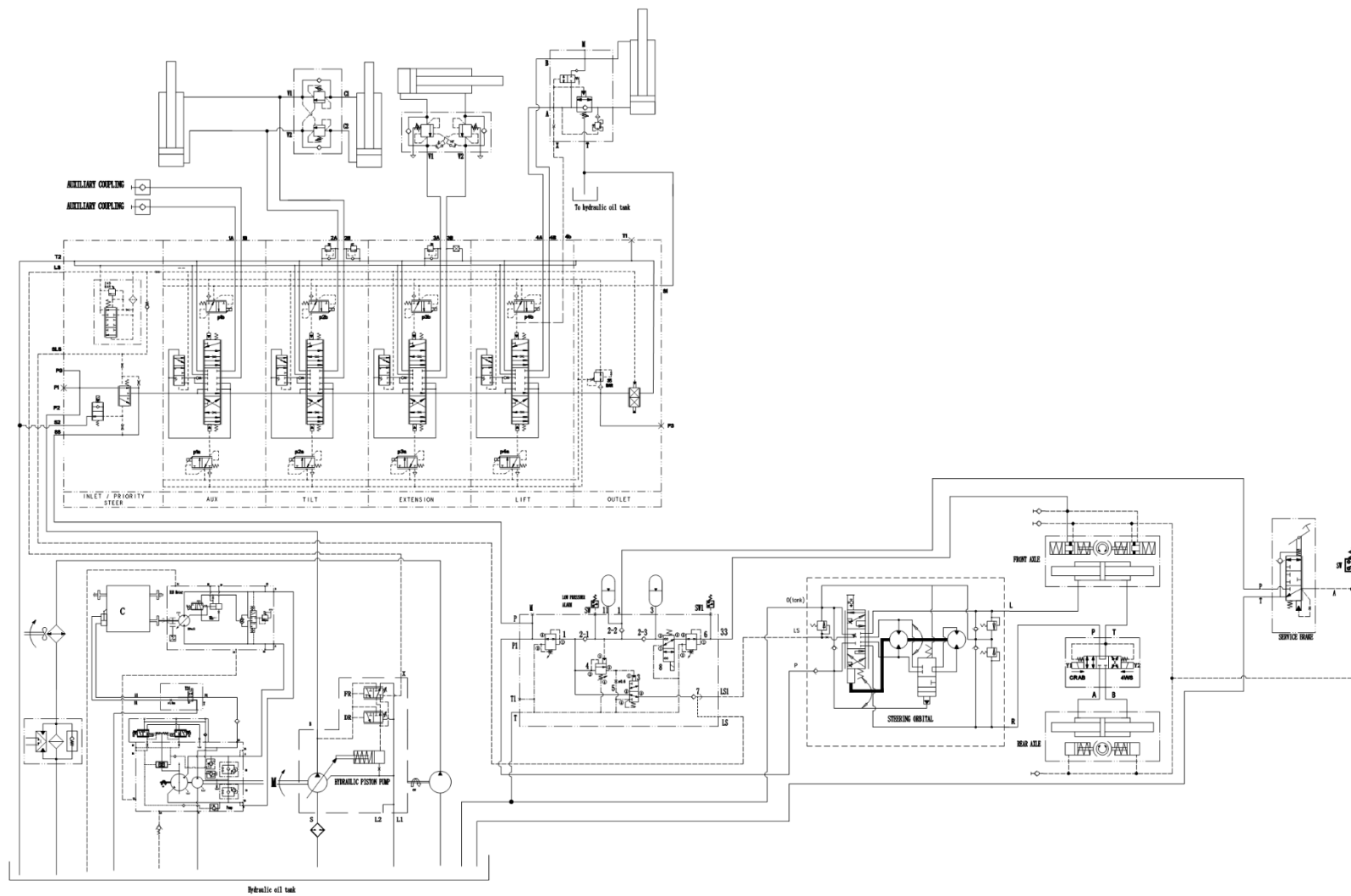



Hydraulic schematic diagram (H07030101K3N1000)

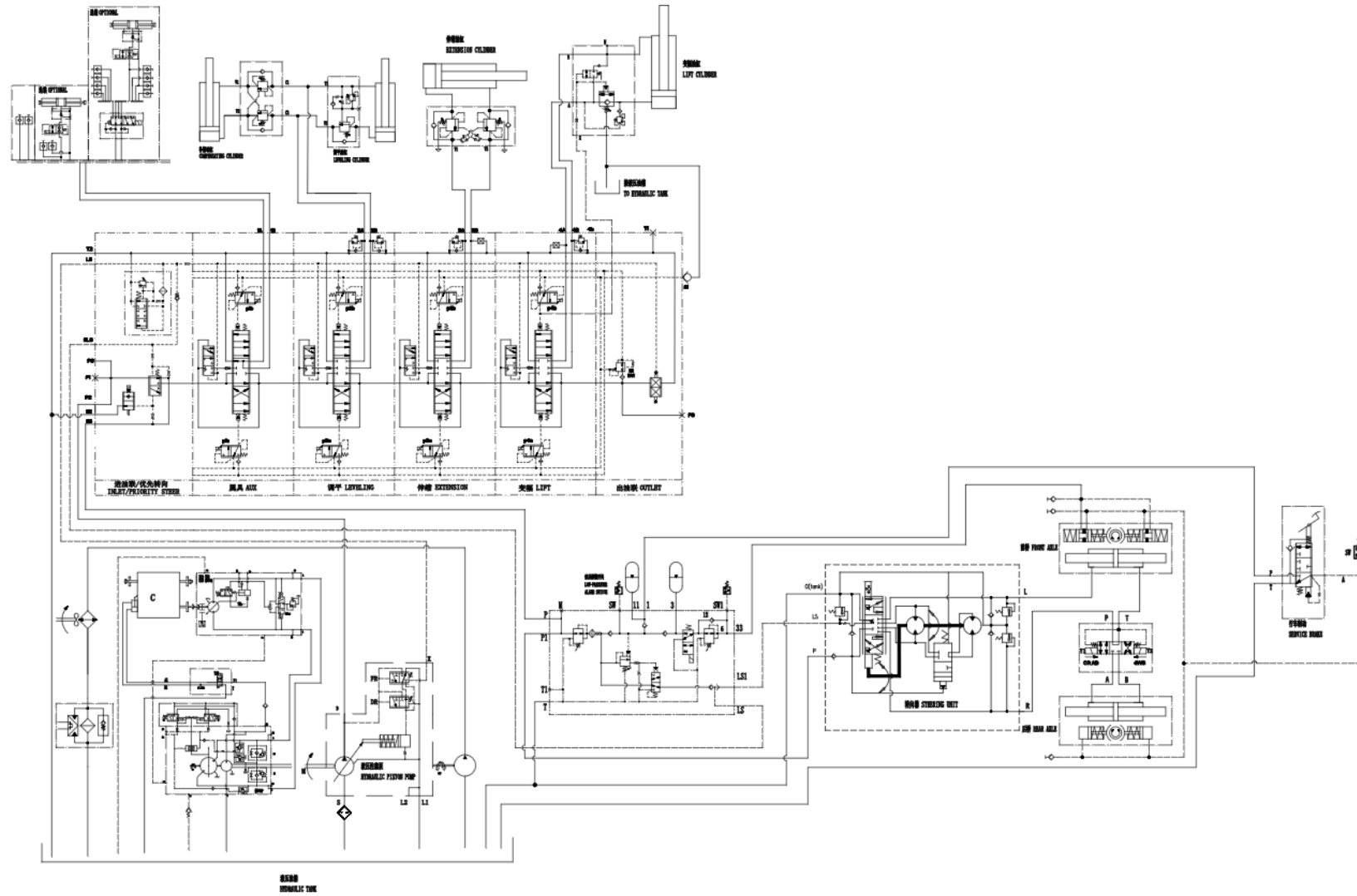



Engine electrical schematic diagram

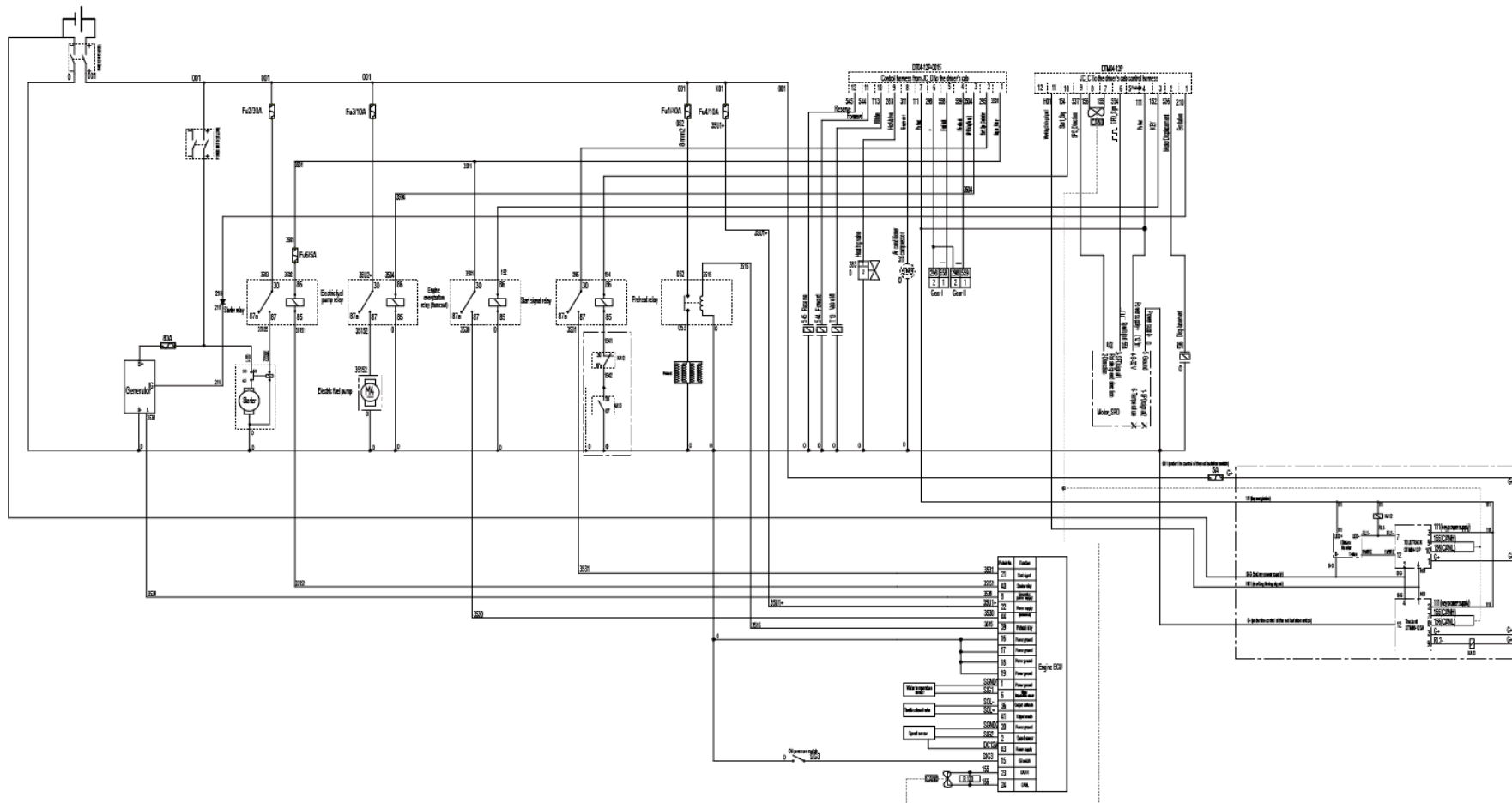



Left & Right combination switch

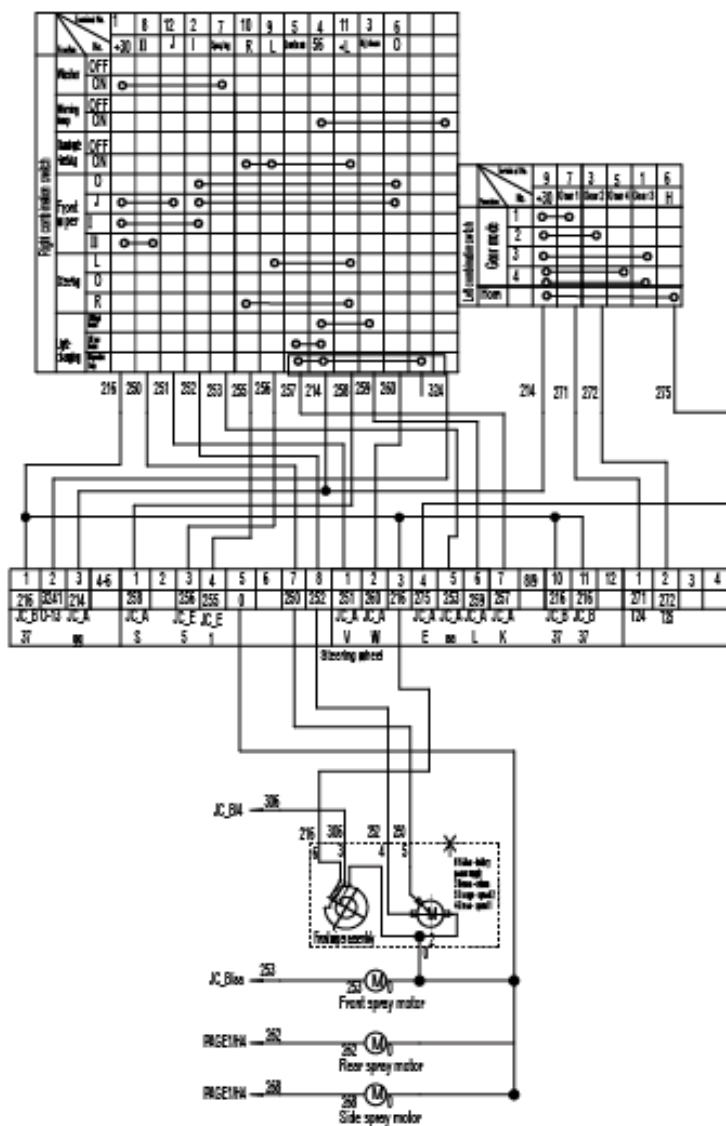



Maintenance Manual of Telescopic Handler

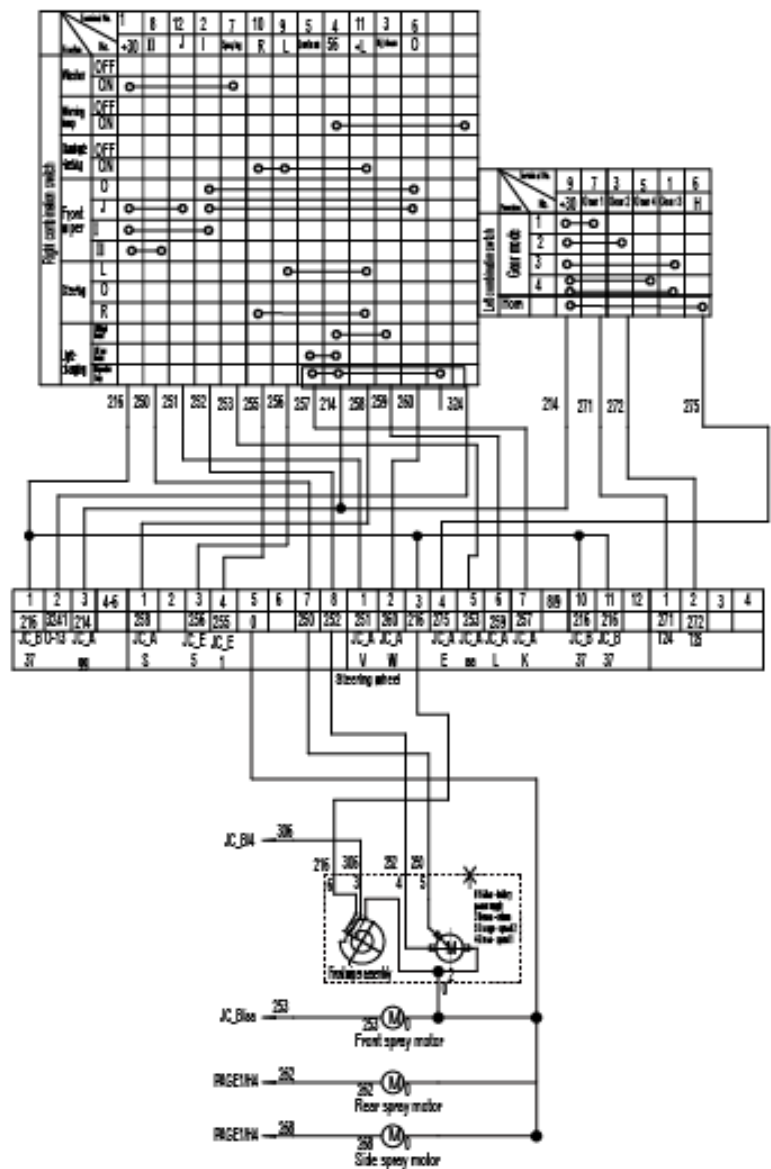



Air conditioner electrical principle

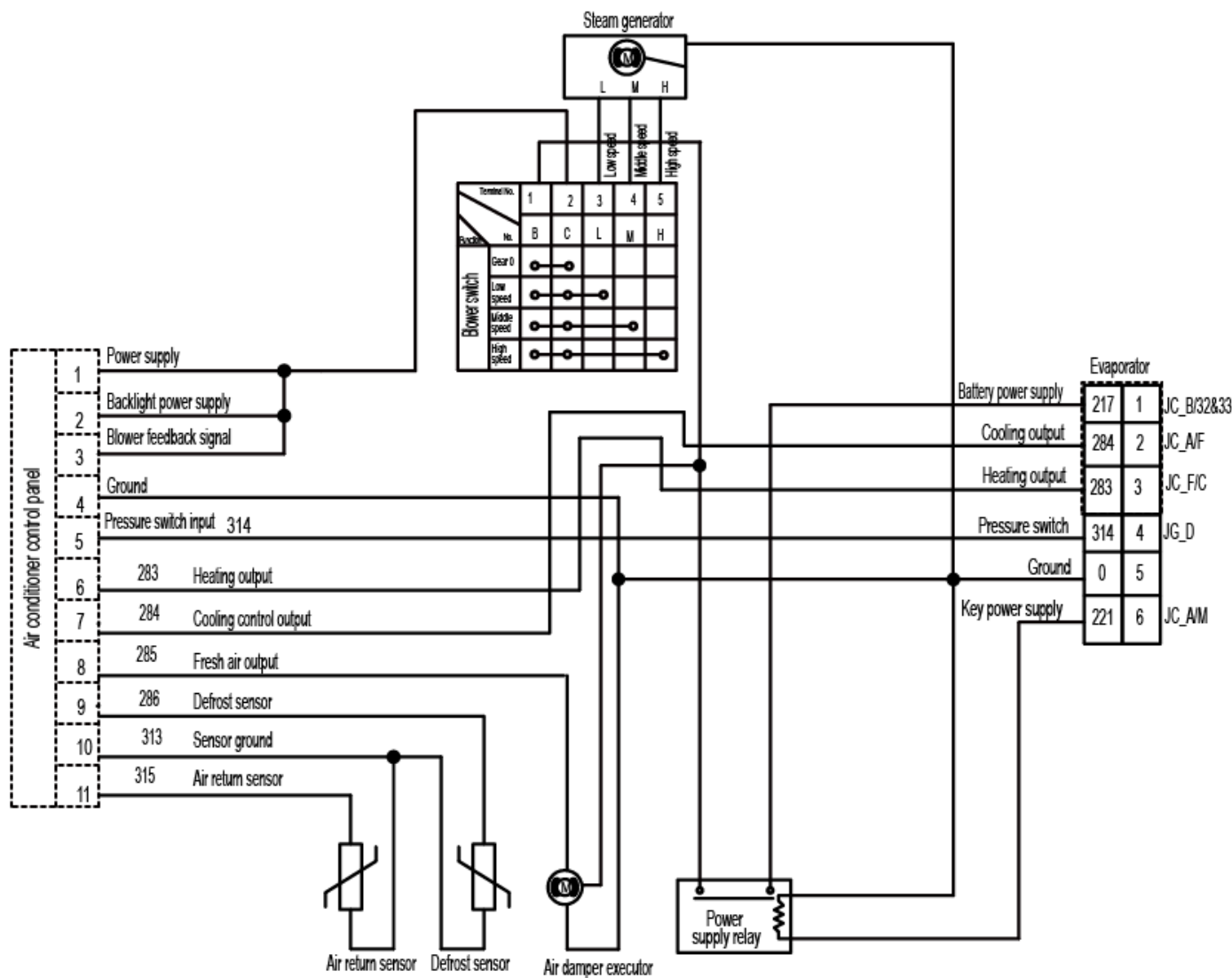



Maintenance Manual of Telescopic Handler

Chassis electrical schematic diagram

Boom electrical schematic diagram

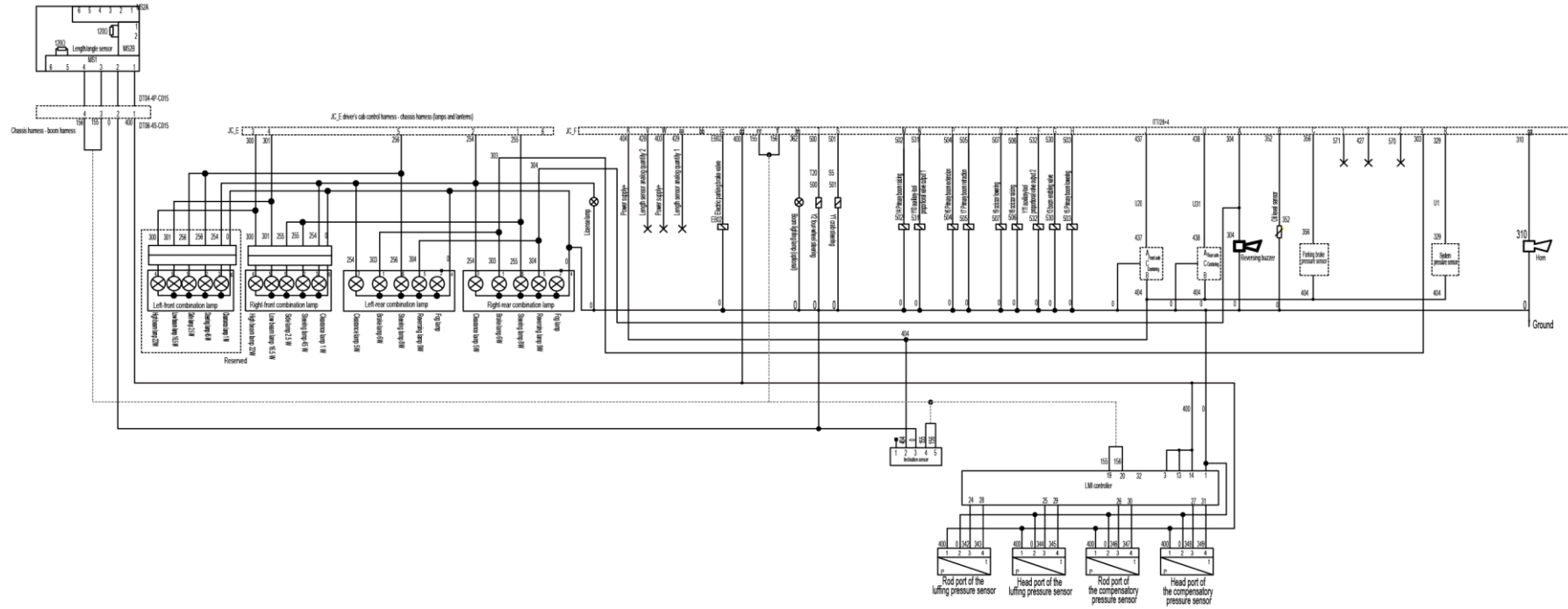



Electrical schematic (H07030101K3N1000)

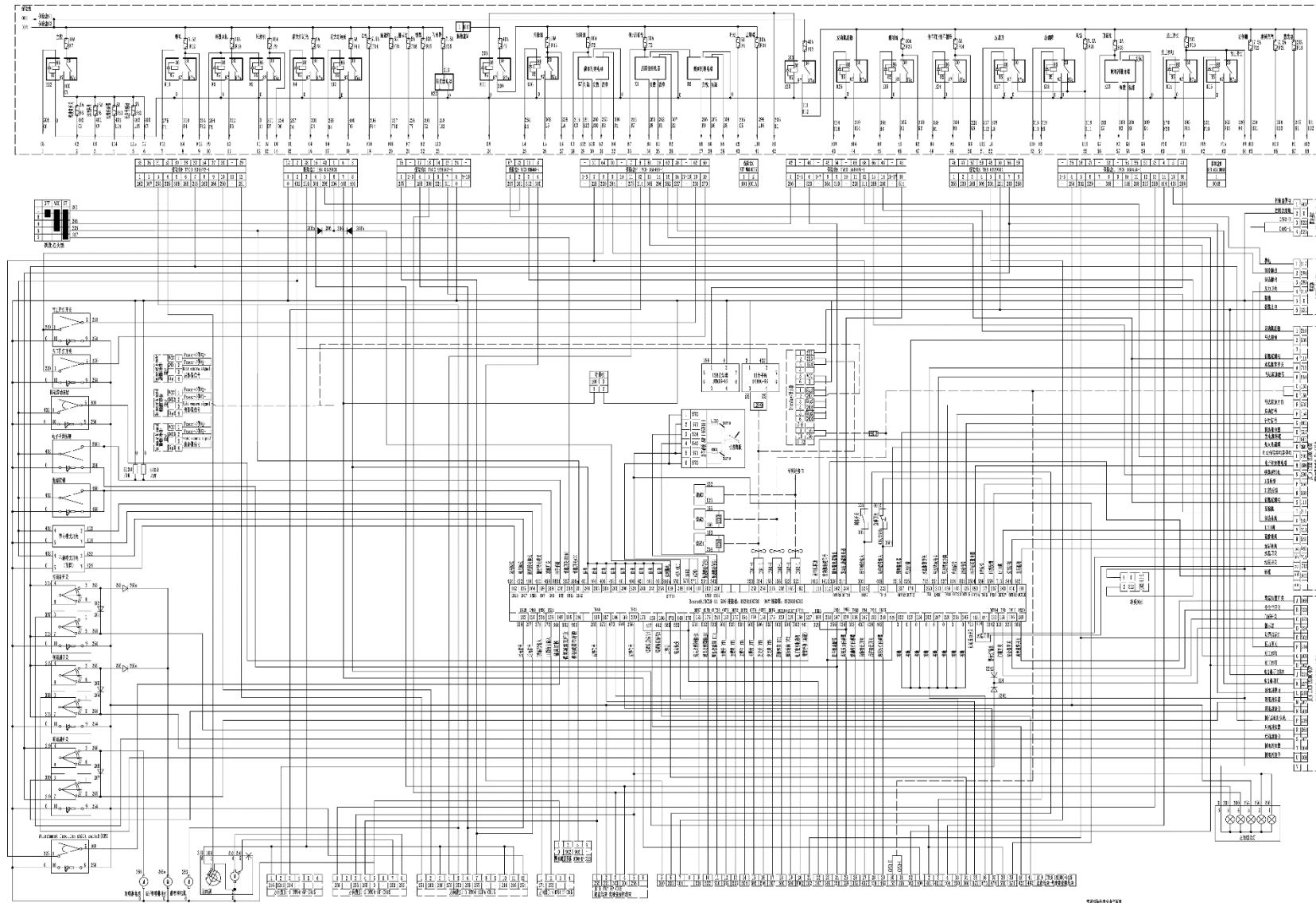



Maintenance Manual of Telescopic Handler

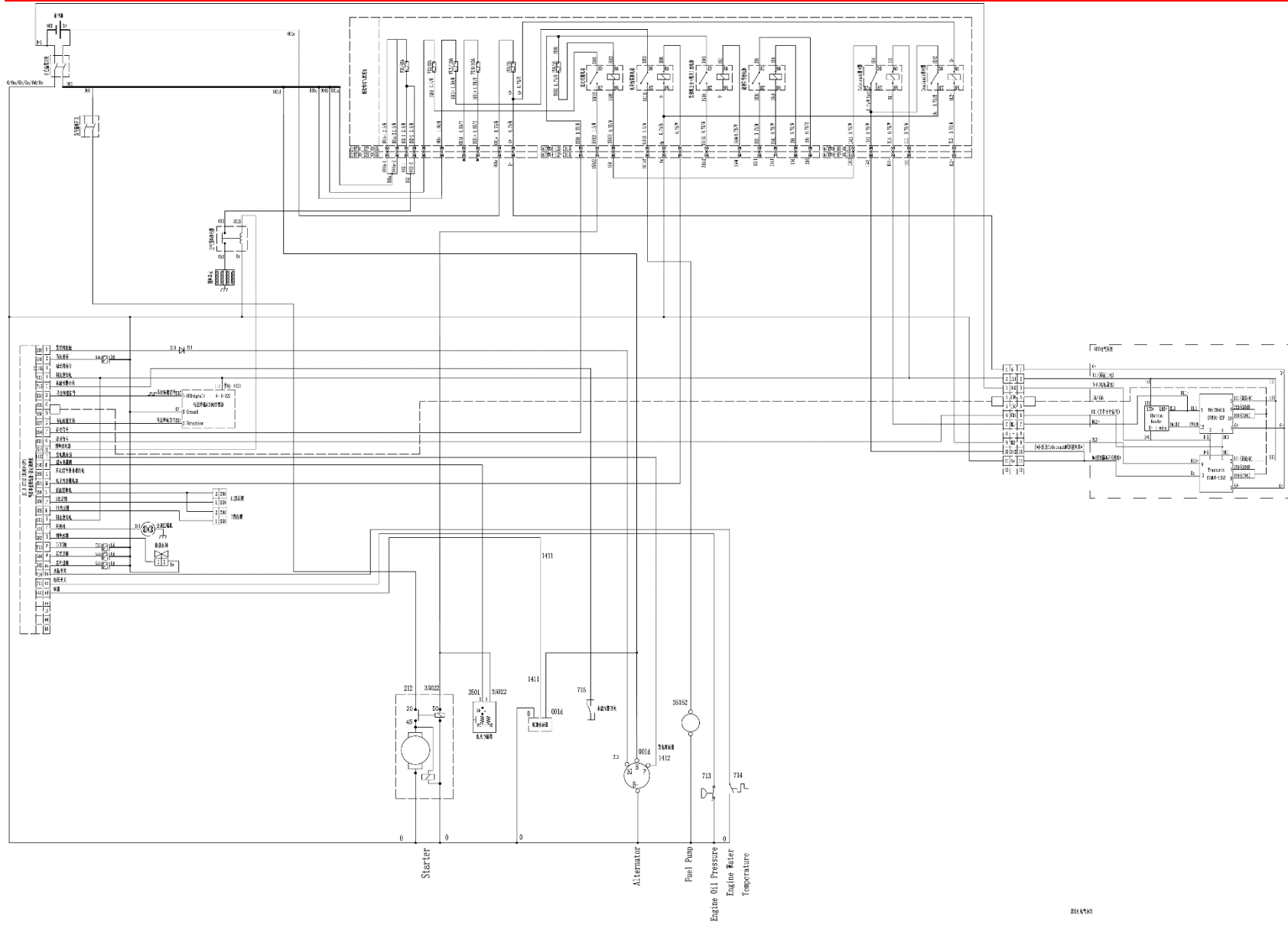



Maintenance Manual of Telescopic Handler

