



Maintenance Manual

EN 1459-1:2017

H1840
Telehandler

PART No. MM-2537060087

Original Instructions

Original Instructions

Thank you for choosing to use this Mobile Elevating Work Platform from LGMG.

This manual is a guide for safe and proper operation and maintenance of the machine, which introduces technical parameters and mechanism and operation herein.

We sincerely hope that you will read through this manual before attempting to operate the machine for the first time and before repairing and maintaining the machine, and that you will master the operation and maintenance described therein.

The information contained in this manual is correct at the time of publication. However, LGMG has endeavored to deliver the highest degree of accuracy possible. And continuous improvement of our product is a LGMG policy. Therefore, product specifications are subject to change without notice.

Due to the impossibility of foreseeing all possible hazards, therefore, it is not possible to include all safety precautions in this manual and the machine's safety precautions in this manual and the machine's safety instructions. If some operations that are not recommended in this manual, you must ensure that you and others are safe and will not damage the machine. If the security of certain operations cannot be determined, please call LGMG industries or dealer service center.

The precautions for operation and maintenance contained in this manual are only applicable when the machine is used for the specified use. If the machine is used within the scope not listed in this manual, our company will not assume any safety responsibility, which is borne by the user and operator in such operations.

Any prohibited operations in this manual shall not be performed.

This manual should always be placed in the designated location for read. This manual is part of the machine, when the ownership or use right of the machine is transferred, please hand over this manual together. If the manual is lost, damaged or illegible, please replace it promptly.

The copyright of this manual this manual is authorized to LGMG and it cannot be copied or reprinted without LGMG's written permission.

2026-4 Version 1 Printed 1

L I N G O N G H E A V Y M A C H I N E R Y C O . , L T D .

Add: 2676 Kejia Road, high tech Zone, Jinan City, Shandong Province, China

Tel: 86-0531-67601108

Fax: 86-0531-67601108

Service Tel: 86-0531-67605016

Web: www.lgmg.com.cn



Safety Rules



Danger

Failure to obey the instructions and safety rules in this manual and the appropriate Operator's Manual on your machine will result in death or serious injury.

Many of the hazards identified in the operator's manual are also safety hazards when maintenance and repair procedures are performed.

Do Not Perform Maintenance Unless:

- ✓ You are trained and qualified to perform maintenance on this machine.
- ✓ You read, understand and obey:
 - manufacturer's instructions and safety rules
 - employer's safety rules and worksite regulations
 - applicable governmental regulations
- ✓ You have the appropriate tools, lifting equipment and a suitable workshop.



Personal Safety

Any person working on or around a machine must be aware of all known safety hazards. Personal safety and the continued safe operation of the machine should be your top priority.



Read each procedure thoroughly. This manual and the decals on the machine, use signal words to identify the following:



Safety alert symbol—used to alert personnel to potential personal injury hazards. Obey all safety messages that follow this symbol to avoid possible injury or death.



Indicates a imminently hazardous situation which, if not avoided, will result in death or serious injury.



Indicates a potentially hazardous situation which, if not avoided, could result in death or serious injury.



Indicates a potentially hazardous situation which, if not avoided, may cause minor or moderate injury.



Indicates a potentially hazardous situation which, if not avoided, may result in property damage.



Be sure to wear protective eye wear and other protective clothing if the situation warrants it.



Be aware of potential crushing hazards such as moving parts, free swinging or unsecured components when lifting or placing loads. Always wear approved steel-toed shoes.

Workplace Safety

Any person working on or around a machine must be aware of all known safety hazards. Personal safety and the continued safe operation of the machine should be your top priority.



Be sure to keep sparks, flames and lighted tobacco away from flammable and combustible materials like battery gases and engine fuels. Always have an approved fire extinguisher within easy reach.



Be sure that all tools and working areas are properly maintained and ready for use. Keep work surfaces clean and free of debris that could get into machine components and cause damage.



Be sure any forklift, overhead crane or other lifting or supporting device is fully capable of supporting and stabilizing the weight to be lifted. Use only chains or straps that are in good condition and of ample capacity.



Be sure that fasteners intended for one time use (i.e., cotter pins and self-locking nuts) are not reused. These components may fail if they are used a second time.



Be sure to properly dispose of old oil or other fluids. Use an approved container. Please be environmentally safe.



Be sure that your workshop or work area is properly ventilated and well lit.



Contents

Revision History	III
Safety Rules	V
Contents	VII
Chapter 1 Maintenance	1
1.1 Checking the safety manual	3
1.2 Checking the labels and signs	3
1.3 Checking for damaged, loose or missing parts	3
1.4 Daily or every 8 hours.....	4
1.5 Every 50 hours or weekly	7
1.6 Every 250 hours	10
1.7 Every 500 hours	15
1.8 Every 1000 hours	21
1.9 Every 1500 hours	24
1.10 Every 2000 hours	25
1.11 Appendix	30



Chapter 1 Maintenance





1.1 Checking the safety manual

It is essential to keep the operation and maintenance manuals in good condition to achieve safe operation of the equipment. If the manual is illegible or missing, the safety and operation information necessary for safe running cannot be provided.

- 1) Confirm that the Operation Manual and the Maintenance Manual are kept intact in the cab.
- 2) Check that every page of the manual is legible and intact.
- 3) Put the manual in the cab after use.

 **To replace any manual, please**

contact the service personnel of LGMG.

1.2 Checking the labels and signs

It is essential to keep all safety and description labels and signs in good condition to achieve safe operation of the equipment. Labels are used to remind the operation and maintenance personnel of potential hazards during operation of the equipment and provide operation and maintenance information for users. Illegible labels cannot remind the maintenance personnel of procedures or hazards and may also lead to unsafe operation.

Check whether all labels are in proper positions with reference to the label section in this manual

and based on the label menu and description.

Check the legibility and condition of all labels, and replace the damaged or illegible labels promptly if any.

 **To replace the labels, please**

contact the service personnel of LGMG.

1.3 Checking for damaged, loose or missing parts

This procedure shall be implemented once every 8h or every day.

It is essential to check the equipment condition regularly to achieve safe operation and superior performance of the equipment. Incorrect positioning or maintenance and part damage, looseness or loss may lead to unsafe operation.

- 1) Check the equipment for damage, incorrect installation or part loss, including:
 - Electrical component, wire and cable
 - Hydraulic hose, connector, valve block and hydraulic cylinder
 - Fuel tank and hydraulic tank
 - Boom chains and sliders
 - Tires and hubs
 - Engine and its relevant parts
 - Limit switch and horn
 - Nuts, bolts and other fasteners
 - Outrigger mechanism
 - Brake pedal and parking brake
 - Indicator light and alarm
 - Drive shaft



Inspect the entire machine to check:

- the welds or structural parts for cracks
- the chassis for deformation or open weld
- the machine for dent or damage
- that all structural parts and other key components are intact and all relevant fasteners and pins are installed in correct positions and tightened

Regular maintenance

In a working environment where is extremely cold, dusty or humid, more frequent lubrication and maintenance than that is specified in "Regular Maintenance" is required. During maintenance, the maintenance items listed in the original requirements shall be carried out repeatedly. For example, when carrying out maintenance items for 250 working hours, the maintenance items for 50 working hours or weekly and every 8 working hours or daily shall be carried out at the same time.

During maintenance, the engine shall be stopped, the machine shall be parked on a solid level ground, the gear selector shall be set to N gear, the parking brake handle shall be pulled up, and the padding block shall be placed under the tires to prevent the machine from moving.

1.4 Daily or every 8 hours

1.4.1 Checking the engine oil level

Insufficient or excessive oil will cause engine damage. The oil level can be checked only when

the engine is placed horizontally and shut down. If the engine is hot, shut it down and check the oil level after 10 minutes so that the engine oil can be discharged into the oil pan. If the engine is cold, check the oil level immediately.

Perkins 1104D:

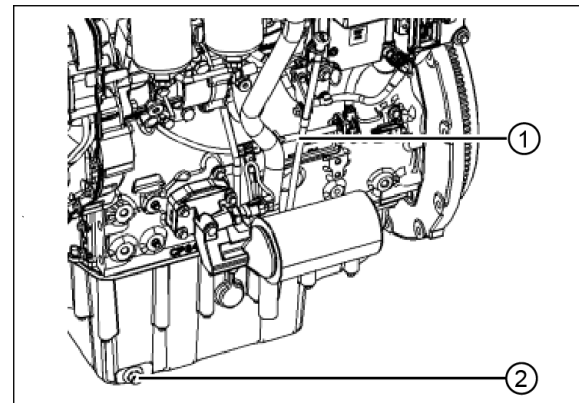

1. Oil dipstick

2. Oil drain plug

- 1) Pull out the oil dipstick and wipe it with a clean cloth, re-insert it into the engine oil level port to the end, and then pull it out for inspection. The oil level should be between the "L" mark and the "H" mark of the oil dipstick.



- 2) If the oil level is below the "L" scale, please add oil through the filler port; If the oil level is above the "H" mark, unscrew the drain plug at the bottom of the oil pan to discharge some oil.

 **CAUTION: Too much or too little**



engine oil will cause engine damage.

1.4.2 Checking the coolant level

Check the coolant level every 8 hours or every day, whichever comes first.

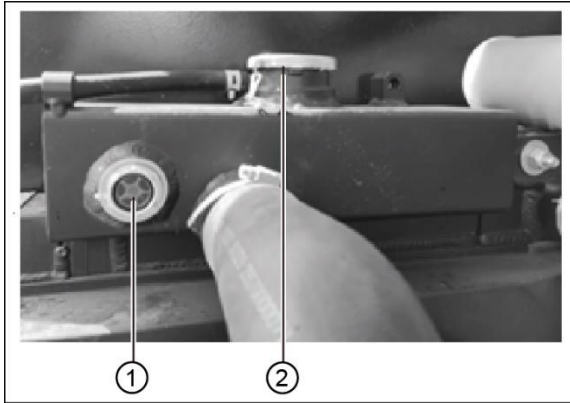

1. Sight hole

2. Filler

- 1) Place the telescopic handler on the horizontal ground, stop the engine and wait till it is cool.
- 2) The coolant level shall not be lower than the middle position of the sight hole (1).
- 3) If necessary, add coolant through the filler (2).



In order to avoid the risk of scalding, wait until the engine is cool enough before removing the cooling circuit filler cap 2.

1.4.3 Checking the fuel level

Check every 8 hours or every day, whichever comes first.

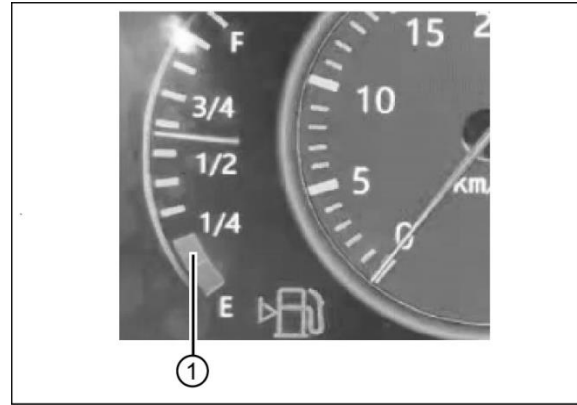

1. Fuel level gauge

- 1) Check the fuel level via the fuel level gauge on the instrument panel.
- 2) Keep the fuel tank full to minimize any condensation due to atmospheric conditions.



CAUTION: Adding should be

always carried out before the diesel in the diesel tank is used up, or, the engine will stall and the diesel at the bottom of the diesel tank will contain more water and impurities, which will affect the normal operation of the engine.



CAUTION: The fuel shall be

selected according to the lowest local temperature when the machine is in use.

1.4.4 Checking the DEF level (If equipped)

Check every 8 hours or every day, whichever comes first.

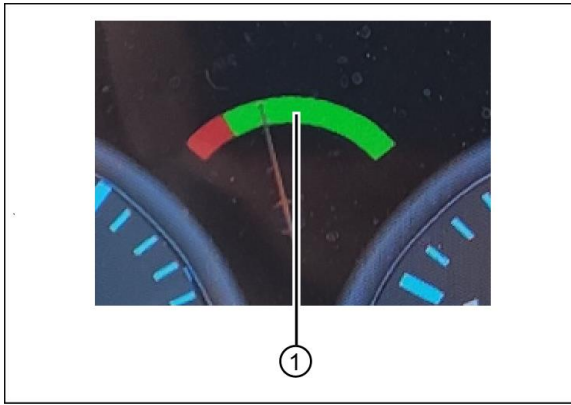

1. DEF level gauge

- 1) Check the DEF level via the DEF level gauge on the instrument panel.

1.4.5 Draining water from the fuel filter

Drain it every 8 hours or every day, whichever comes first.



Explosion and fire hazard. Engine fuel is combustible. Check the location of the equipment. This step shall be performed in open and well-ventilated areas away from heaters, sparks, flames, and burning tobacco. A conforming fire extinguisher should be placed in an easily accessible place.



This step shall be performed when the engine is shut down.

Perkins 1104D:

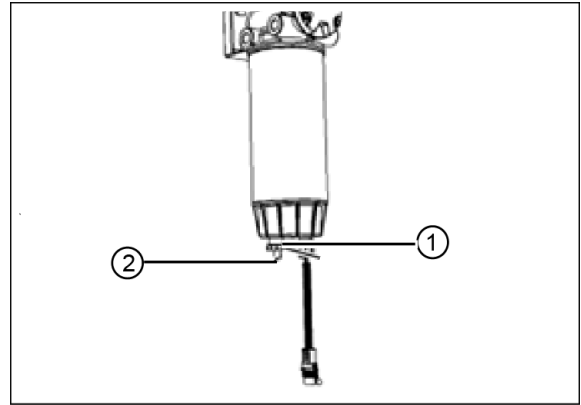

1. Drain valve

2. Connector

- 1) Place the container under the drain valve.
- 2) Install a suitable tube on the connector (2), then open the drain valve (1) to drain the liquid from the filter and close the drain valve immediately when the clean fuel is drained.
- 3) Wipe away the spilled fuel oil.

1.4.6 Checking the tire pressure and wheel nut torque

Drain it every 8 hours or every day, whichever comes first.

- 1) Check treads and sides of tires for scratches, cracks, punctures, and other abnormal wear.
- 2) Check if the hubs are damaged, bent or cracked.
- 3) Check and adjust the tire pressure if necessary:

Model	Speed (km/h)	Single tire load (Kg)	Tire pressure (kpa)
H1840	40	5600	500



Tightening torque of wheel nut:

Model	Front axle	Rear axle
H1840	780-880N.m	780-880N.m



CAUTION: Check whether the air

hose is properly connected to the tire valve before inflation and keep a certain distance from everyone during inflation.

1.4.7 Checking the hydraulic oil level

Check every 8 hours or every day, whichever comes first.

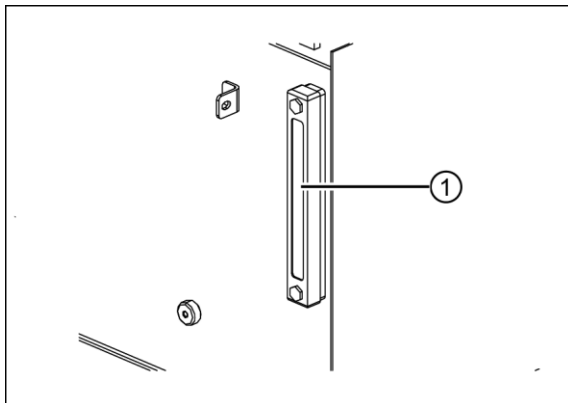

- 1) When checking the hydraulic oil level, park the handler on a flat ground. The hydraulic oil level for storage shall be not less than 1/2 of the level meter.

1.5 Every 50 hours or weekly

1.5.1 Cleaning radiator

This item is performed every 50 hours or weekly, whichever comes first.

Clean and flush the cooling system before the recommended maintenance interval if the

following conditions occur:

- The engine overheats frequently.
- Coolant foaming was observed.
- The oil has entered the cooling system and the coolant is contaminated.
- The diesel fuel has entered the cooling system and the coolant is contaminated.



CAUTION:

Cleaning radiator should always be carried out when the engine is shut down.



CAUTION:

If the operation isn't performed carefully, the radiator core will be prone to damage.

- 1) Clean the radiator through blowing from the air outlet side of the radiator with compressed air.
- 2) Clean the inside of the radiator with a soft cloth.

1.5.2 Checking washer fluid level

This item is performed every 50 hours or weekly, whichever comes first.

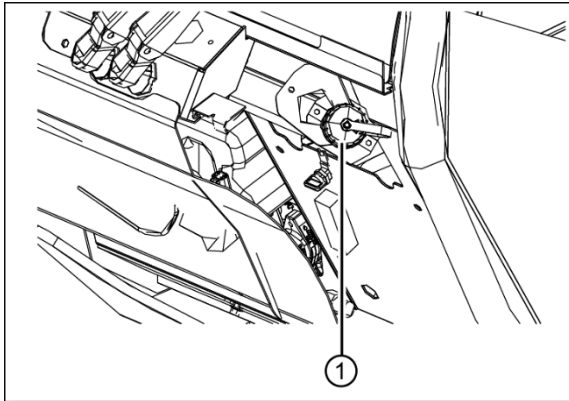
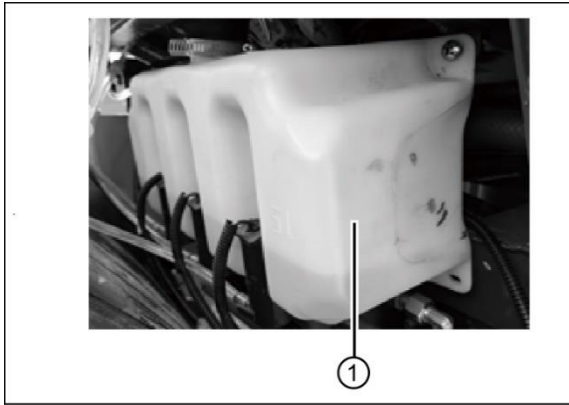

- 1) Remove protective cover.
- 2) Check the level in the water tank (1).
- 3) If necessary, add washer fluid by filler (2).

1.5.3 Cleaning the cab A/C filter

This item is performed every 50 hours or weekly, whichever comes first.

A. Cab outer filter element

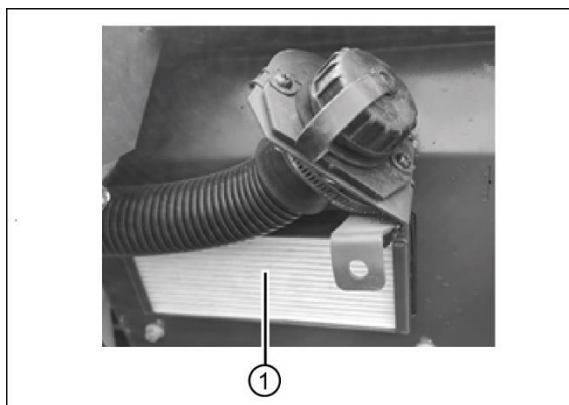

- 1) Remove the protective cover.
- 2) Take out the A/C filter element (1) and clean it with compressed air. If the filter element is

damaged, replace it.

- 3) Install the filter element (1) and housing.

B. Cab inner filter element

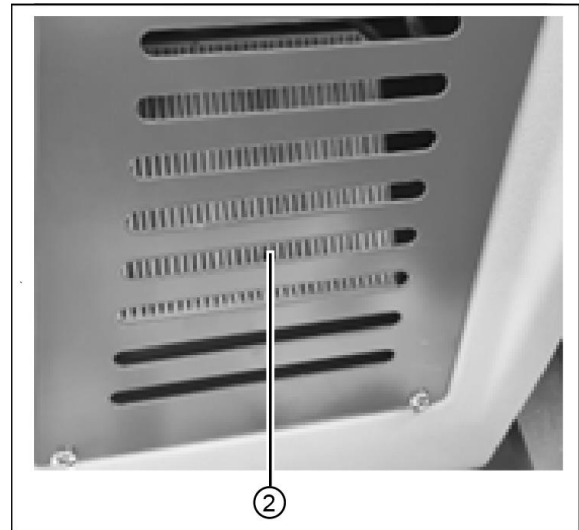

- 1) Remove the shield.
- 2) Take out the A/C filter element (2) and clean it with compressed air. If the filter element is damaged, please replace it.
- 3) Install the filter element and the shield.

1.5.4 Checking the transmission

fluid level (If equipped)

This item is performed every 50 hours or weekly, whichever comes first.

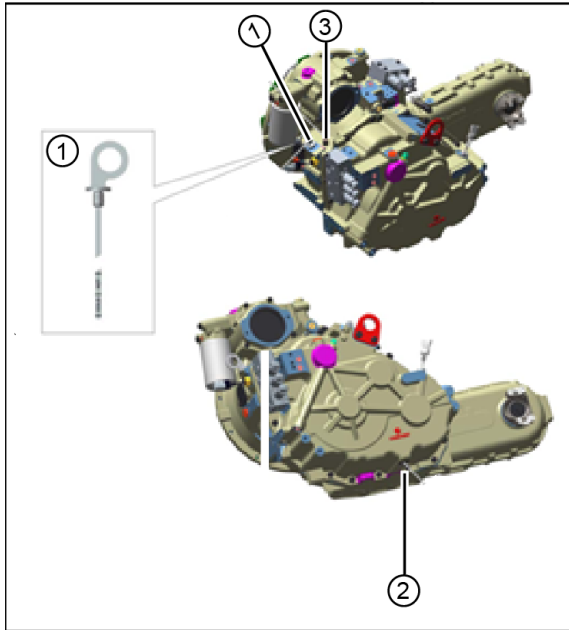

No.	Description
1	Oil filler/oil dipstick
2	Oil outlet
3	Breather

1. Stop the engine, park the machine on a level ground, set the gear selector to N gear, pull up the parking brake handle, and chock the tire to prevent the machine from moving.

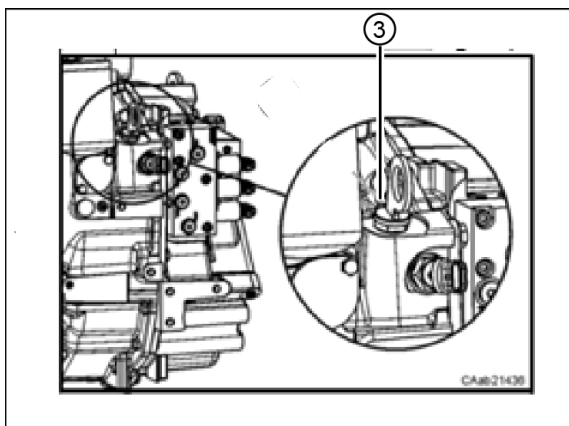

2. Carefully clean the breather (3) and surrounding area.

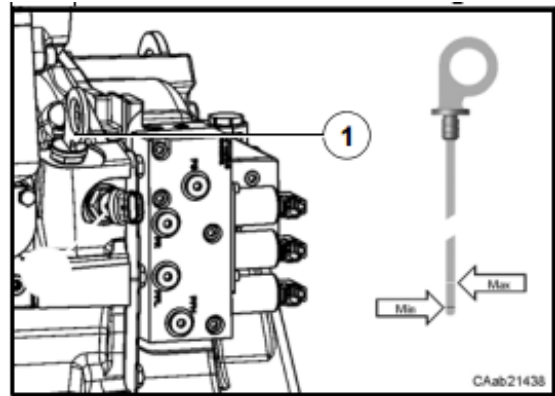

3. Unscrew the oil dipstick (1), wipe it with a cloth, insert it back to the original place, and pull it out again to check the oil stain. The oil level shall be between the maximum and minimum limits on the oil dipstick (hot range or cold range). If the oil level is above the maximum of the hot/cold range, drain the oil and if the level is below the minimum, add the oil according to the standard.

! CAUTION: High/low transmission fluid level will cause damage to the transmission. Please keep the transmission fluid level in the correct position.

! CAUTION: During the process of checking the transmission fluid level and replacing the transmission fluid, pay attention to cleanliness to avoid entering of dirt into the transmission system and damaging the transmission.



1.6 Every 250 hours

1.6.1 Replacing cab A/C filter

This item is performed every 250 hours or quarterly, whichever comes first.

A. Replace the cab outer filter element

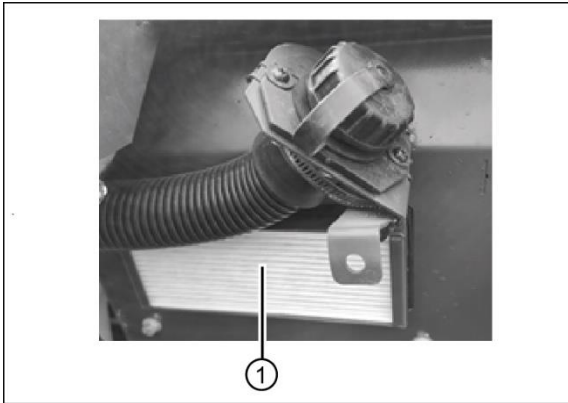

- 1) Remove the protective cover.
- 2) Take out the A/C filter element and replace with a new filter element (1).
- 3) Install the protective cover.

B. Replace the cab inner filter element

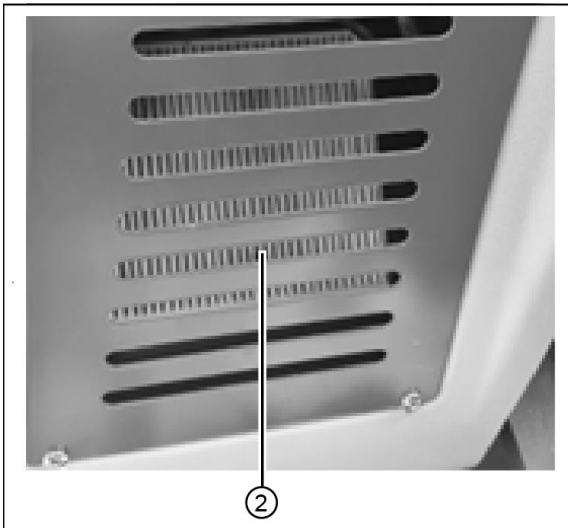

- 1) Remove the shield.
- 2) Take out the A/C filter element and replace it with a new one.
- 3) Install the protective cover.

1.6.2 Check the drive axle final drive and wheel reducer oil level

This item is performed every 250 hours or quarterly, whichever comes first.

! CAUTION: Before the operation, the engine shall be stopped, the vehicle shall be parked on a level surface, the parking brake handle shall be pulled up, and the tire shall be blocked to prevent the machine from moving.

! CAUTION: To discharge, fill and check the oil level, the drive axle must be horizontal and mounted on the vehicle.

Check the reducer oil level every 250 hours or quarterly. Improper reducer oil level will lead to equipment performance degradation, and continuous use will lead to component damage.

Check the oil level of the final drive

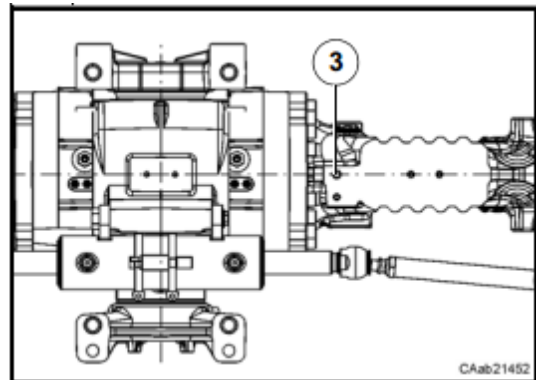

- 1) Carefully clean the breather (3) and surrounding area.

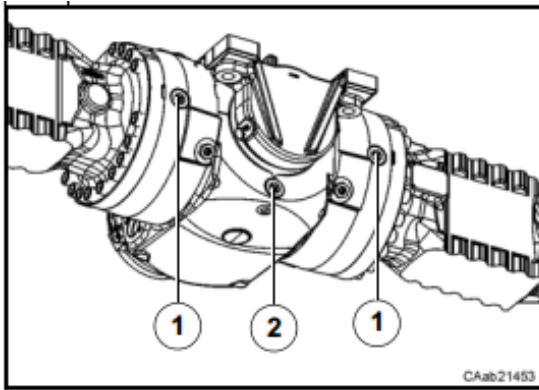

- 2) Check the oil level: remove the oil filler plug (1) and check whether the oil level is at the lower edge of the filler. Otherwise, add oil and tighten the plug.

Check drive axle wheel reducer oil

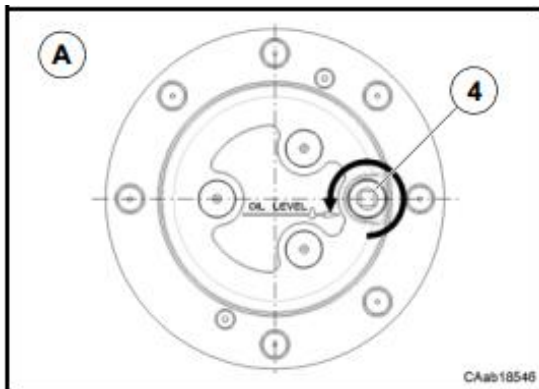

1. Turn the wheel so that the plug (4) is in the highest position and unscrew it to some extent to release the possible pressure.
2. Turn the wheel so that the plug (4) is in the horizontal position, remove the plug to check whether the oil level is at the lower edge of the oil filler , otherwise add oil and tighten the plug.

1.6.3 Checking transfer box oil level (If equipped)

This item is performed every 250 hours or quarterly, whichever comes first.

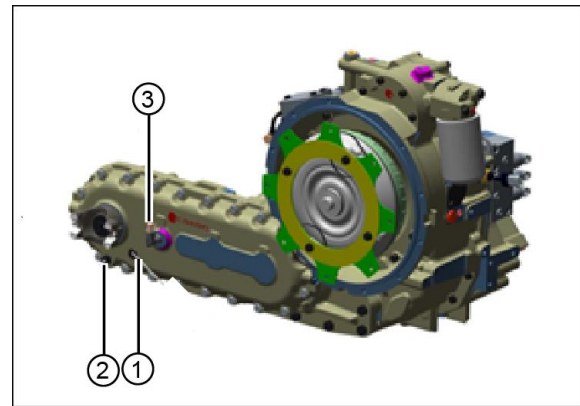

No.	Description
1	Oil filler
2	Oil outlet
3	Breather

Check the transfer box oil level

- 1) Stop the engine, park the machine on a level ground, set the gear selector to N gear, turn off the engine, pull up the parking brake handle, and chock the tire to prevent the vehicle from moving.
- 2) Carefully clean the breather (3) and surrounding area.
- 3) Remove the oil filler plug (1), and check whether the level is at the lower edge of the oil filler. Otherwise, fill the oil to the specified position and install the plug (1).

1.6.4 Checking transfer box oil level (If equipped)

This item is performed every 250 hours or quarterly, whichever comes first.

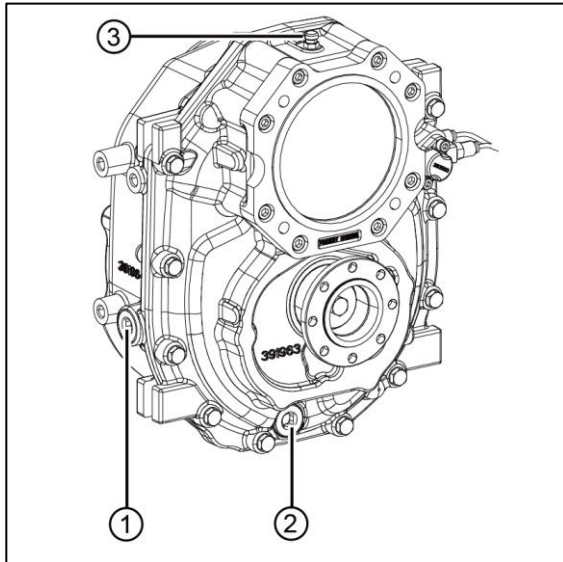

1. Oil filler \ Oil level sight glass

2. Oil outlet

3. Breather

- 1) Stop the engine, park the machine on a level ground, set the gear selector to N gear, pull up the parking brake handle, and chock the tire to prevent the machine from moving.
- 2) Carefully clean the breather (3) and surrounding area.
- 3) Oil level inspection: remove the oil filler plug (1) and check whether the oil level is on the lower edge of the filler, otherwise add oil.
- 4) Tighten the plug.

1.6.5 Checking boom chain

This item is performed every 250 hours or quarterly, whichever comes first.

Cleaning and lubricating boom chain

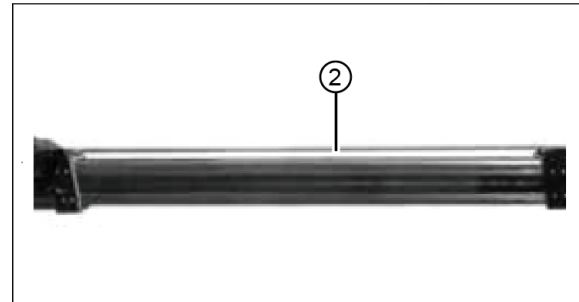
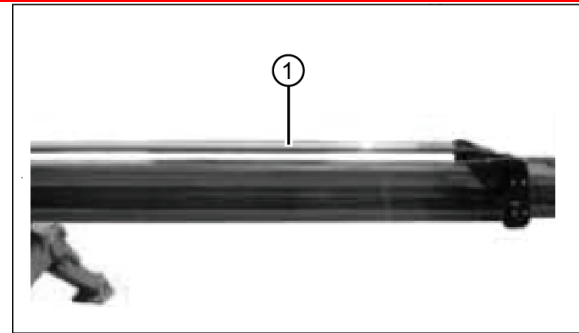

- 1) Raise the outrigger and keep the boom level.
- 2) Fully extend the boom.
- 3) Wipe the chain outside the boom with a clean lint-free cloth, and then check carefully of any wear.
- 4) Brush the chain with a hard nylon brush and clean diesel fuel to remove any foreign matter.
- 5) Brush the chain with a paint brush soaked in cleaning diesel fuel and blow dry it with compressed air.
- 6) Lubricate the chain with lubricant, extend and retract the boom several times to check the performance of the chain.

Check chain tension

- 1) Fully extend the boom and retract the boom by 200 mm.

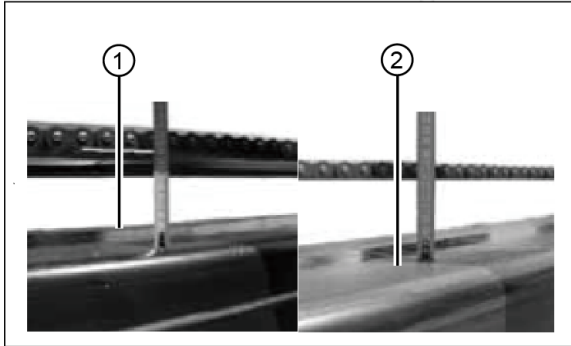

- 2) Measure the distance between the bottom of the chain and the top of the boom with a ruler. The distance of the two same chain must be consistent.

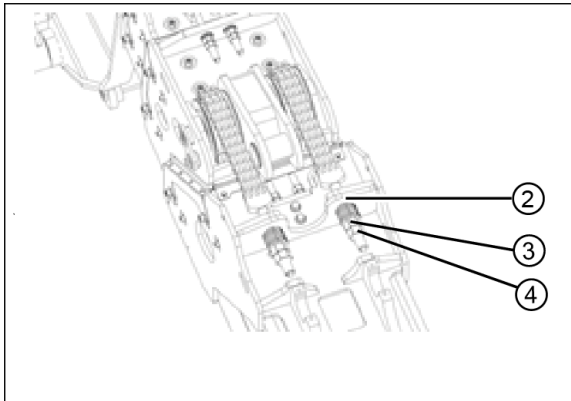

- 3) Boom 1: The distance shall be between 97 mm and 117 mm, and if necessary, adjust it with tensioner "2". Loosen lock nut "3" and tighten nut 4 until the desired distance is reached. Retighten the lock nut "3" while limiting the nut "4".

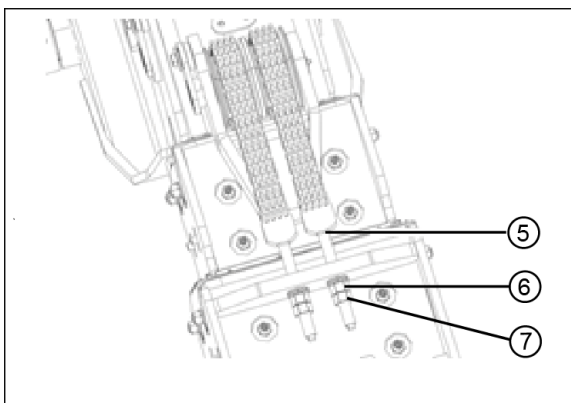

- 4) Boom 2: The distance shall be between 65

mm and 85 mm. If necessary, adjust with tensioner "5". Loosen lock nut "6" and tighten nut "7" until the desired distance is reached. Retighten the lock nut "6" while limiting the nut "7".

! CAUTION: If the Chain is too long to adjust the tension, replace it in pairs. If one of the chain is damaged, the two chains shall also be replaced together.

1.6.6 Lubricating boom slider

Carry it out every 10 hours for the first 50 hours and every 250 hours thereafter.

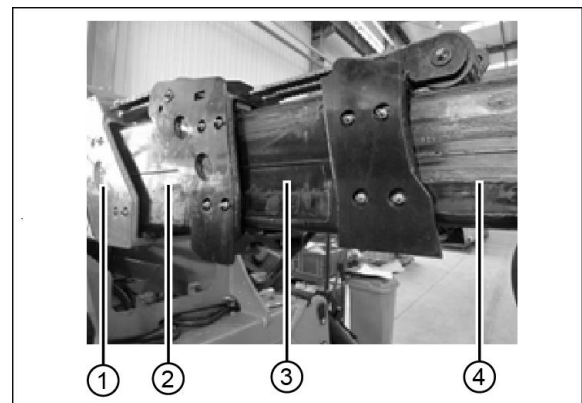

1. 1st boom
 2. 2nd boom
 3. 3rd boom
 4. 4th boom
- 1) Raise the outrigger (If equipped with outrigger).
 - 2) Extend the boom as much as possible.
 - 3) Apply grease evenly around the boom with a brush (KunLun HP-R high temperature grease is recommended).
 - 4) Remove excess grease and retract the



boom.

1.6.7 Checking hydraulic oil

This item is performed every 250 hours or quarterly, whichever comes first.

Collect a hydraulic oil sample, place it in a transparent container, and visually inspect the hydraulic oil as follows:

- Color: the oil shall be transparent and appear in light honey color.
- Appearance: the oil shall be clear, not cloudy, and free of particles, foreign matters or other contaminants.
- Check the hydraulic oil through the smell (the heat can be smelled, but there is no "burnt" smell) or the friction between the fingers (there shall be a sticky feeling, no rough feeling of any particles). If all hydraulic oil pass the above inspection, continue to service at predetermined intervals. If the hydraulic oil does not comply with any of the above inspections, the hydraulic oil must be tested or replaced.

- 1) Replacement or testing of hydraulic oil is critical to the performance and service life of the equipment. Contaminated hydraulic oil may affect equipment performance, and continuous use will cause equipment damage. For harsh working environment, the inspection should be carried out more

frequently.

- 2) Before replacing the hydraulic oil, the oil stain separator can be used to test whether it is necessary.
- 3) If the hydraulic oil has not been replaced for two years, it shall be tested quarterly. If it fails to pass the test, replace the hydraulic oil.

Note: when replacing the hydraulic oil, it is recommended to replace all hydraulic filters at the same time.

1.6.8 Check for Batteries

This check item is performed every 250 hours or quarterly, whichever comes first.

Keep away from fireworks and remove all rings, watches and other accessories. Wear goggles, protective gloves and protective clothing if necessary. Avoid touching the spilled electrolyte with hands or other parts of the body. Neutralize with baking soda and the spilled electrolyte.

Good battery condition is essential for machine performance and safe operation. Improper voltage or damaged cables and wiring may cause component damage and dangerous situations.

Maintenance-free lead-acid battery inspection:

- Check that the battery locking lever is secure



- Check the wiring of the battery cable. The wiring is firm and free from corrosion.
- Check whether the battery fluid leaks and whether the battery is dry and clean.
- Check the color of the battery hydrometer as shown in the figure:

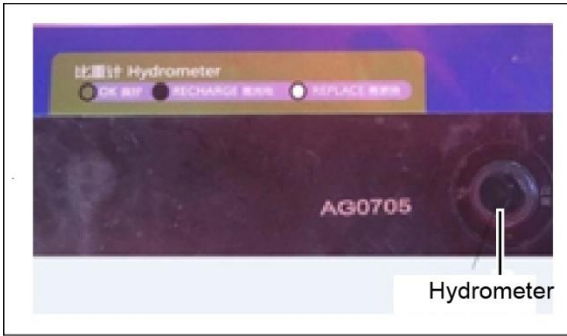

Battery

Hydrometer color	Meaning and treatment
White	Lack of battery fluid. Please shut down the machine and stop using it
Black	Power loss or damage
Green	Measure the voltage of each battery. If the voltage is lower than 11V, it indicates that the battery is damaged; The voltage is between 12.4v-12.7, indicating that the battery is in good condition

- If the color of the battery hydrometer is green and the voltage is above 12V, but the starter cannot be driven, please ask the personnel trained and qualified for the maintenance of the machine to further test the battery.

⚠ Note: If an external power supply is required to charge the

battery, only the charger approved by the LGMG can be used.

- Do not replenish the battery with white eyes. Replace the battery.
- When wiring after charging, connect the positive wire first and then the negative wire.

⚠ Notice: Adding a terminal protector and an anti-corrosion sealant will help remove corrosion caused to battery terminals and cables.

1.6.9 Cleaning air filter element

Clean the main filter element every 250 hours or when the air cleaner blocking alarm sounds or the maintenance indicator turns red.

It is forbidden to clean the safety filter element.

For detailed steps, please refer to **1.8.1**

Replacing air filter element.

1.7 Every 500 hours

1.7.1 Replacing engine oil and oil filter

First 50 hours, and then change it every 500 hours or every half a year, whichever comes first.

⚠ Do not work on the running engine!

No smoking and open fire!

Be careful when handling high



temperature engine oil. Risk of burning!

 When working on the oil system, pay attention to the cleanliness of the outer surface. Carefully clean all areas involved. Dry the wet parts with compressed air.

 Please abide by the oil safety provisions and local regulations. Dispose of spilled oil and filter elements as specified. Ensure that waste oil doesn't drip to the ground.

Draining engine oil

Perkins 1104D:

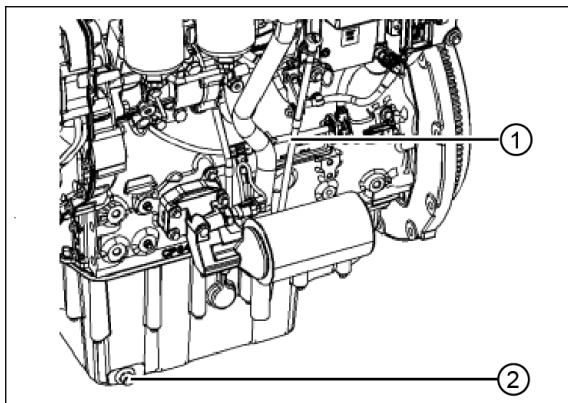

1. Oil dipstick
2. Oil drain plug
 - 1) Warm up the engine.
 - 2) Place the engine horizontally.
 - 3) Shut down the engine.
 - 4) Place a container under the oil drain plug.
 - 5) Unscrew the oil drain plug, and drain the old oil.
 - 6) Install a new seal ring on the oil drain plug,

screw the oil drain plug in and tighten it.

Replacing the oil filter

 CAUTION: Each time the oil is changed, the oil filter element should also be replaced.

Perkins 1104D:

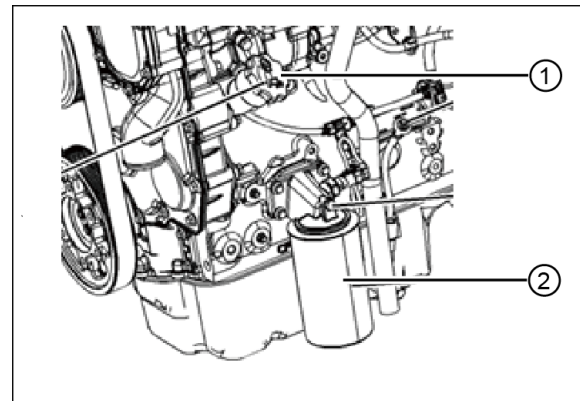

1. Oil filler plug
2. Oil filter
 - 1) Clean the area near the oil filter mounting seat.
 - 2) Remove the oil filter with the belt wrench.
 - 3) Clean the gasket contact surface of the mounting with a clean cloth.
 - 4) Apply a clean coat of oil to the new oil filter O-ring.
 - 5) Screw in the new oil filter until the O-ring contacts the oil filter base and rotate the oil filter for 3/4 full turns.

 CAUTION: Excessive mechanical tightening may damage the thread or damage the seal of the oil filter element.

Adding oil.



Perkins 1104D:

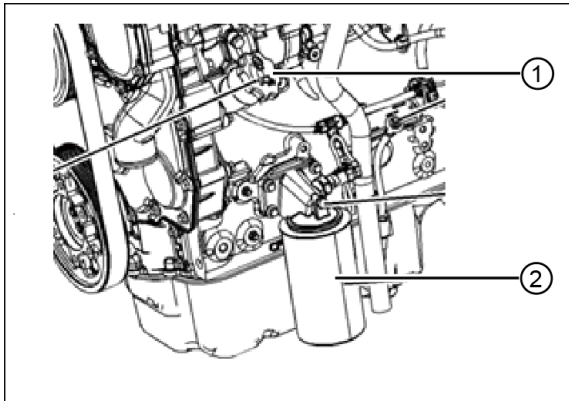

1. Oil filler plug
2. Oil filter
 - 1) Add oil through the oil filter.
 - 2) Wait a few minutes for oil to flow into the oil pan.
 - 3) Warm up the engine and run it at low speed for 3 minutes to check the drain plug and the filter for leakage.
 - 4) Turn off the engine, wait a few minutes, check the oil level and refill if necessary.

1.7.2 Replacing primary fuel filter element

Replace every 500 hours or every six months, whichever comes first.

⚠ Engine must be turned off!

No smoking and open fire!

Be careful when handling hot fuel!

⚠ Do not loosen the fuel injection pipeline or high pressure fuel pipeline while the engine is running.

⚠ Carefully clean all areas involved.

Dry the wet parts with compressed air.

⚠ Please observe safety regulations on fuel and relevant local laws and regulations. Dispose of spilled fuel and filter elements according to regulations. Fuel must not leak to the ground.

⚠ After the operation on the fuel system is completed, bleed the system, conduct a trial run and check the tightness.

⚠ Explosion and fire hazard. Engine fuel is combustible. Check the location of the machine. This step shall be performed in open areas away from heaters, sparks, flames, and burning tobacco. A conforming fire extinguisher should be placed in an easily accessible place.

Perkins 1104D:

⚠ The secondary fuel filter element must be replaced at the same time as the primary fuel filter element.

- 1) Turn the fuel supply valve (if equipped) to the OFF position.
- 2) Clean the mounting and the area around the



filter.

- 3) Place the container under the drain valve.

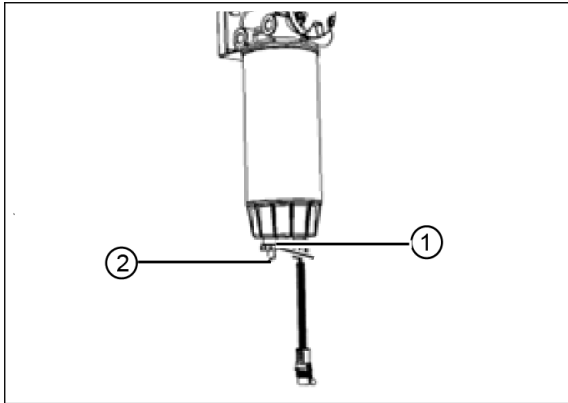

- 4) Connect a suitable tube to the connector (2), then open the drain valve (1) to drain the filter. Allow the liquid to flow into the container.

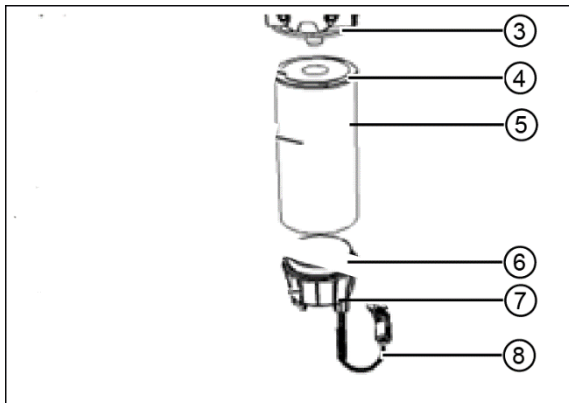

- 5) Disconnect the electrical connector (8), then manually remove the connecting oil cup (7) and remove the old O-ring (6). Clean the oil cup (7).
- 6) Remove the fuel filter (5) with the belt wrench.
- 7) Apply a thin layer of diesel fuel to the new filter seal ring.
- 8) Reinstall the fuel filter and rotate it 3/4 of a full turn after the O-ring touches the filter base (3).
- 9) Install the electrical connector (8). Take out

the container and dispose the fuel in accordance with local regulations, and if necessary, switch on the fuel supply valve.

- 10) Bleed the fuel system.

1.7.3 Replacing secondary fuel filter

Perkins 1104D:

Note: The two fuel filter elements must be replaced.

- 1) Ensure that the fuel supply valve (if equipped) is in the OFF position.
- 2) Place a suitable container under the fuel filter to collect all spilled fuel.

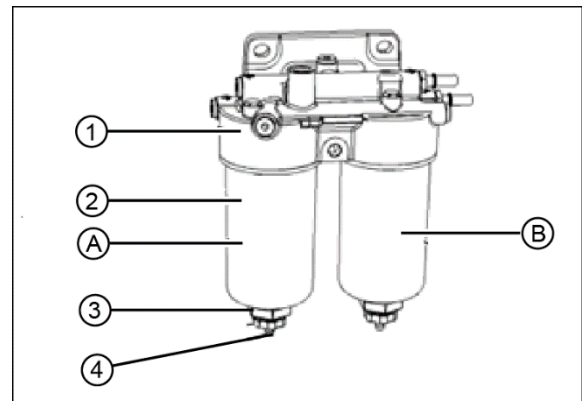

- 3) Install a suitable tube on the connector (4). Rotate the drain valve (3) counterclockwise to discharge the fuel and remove the hose.
- 4) Rotate the filter fuel cup (2) counterclockwise to remove it from the filter housing (1).

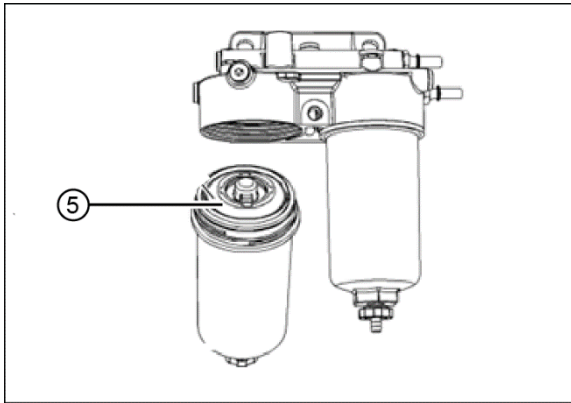

- 5) Rotate the filter element (5) counterclockwise and remove the filter element. Clean the filter fuel cup.

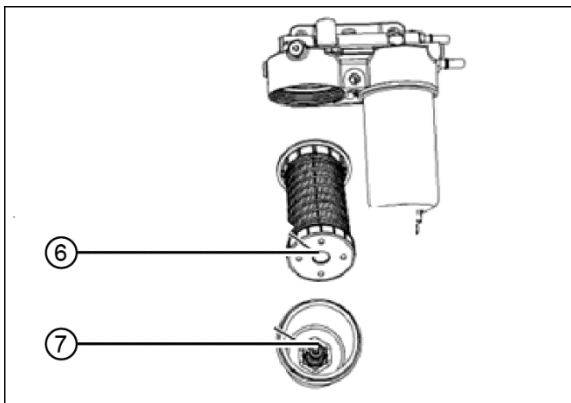

- 6) Replace with a new filter element and position the thread (7) on the thread (6). Rotate the new filter element and manually tighten the drain valve (3).
- 7) Apply a thin layer of fuel to the new filter seal ring. Do not add fuel to the filter fuel cup (2).
- 8) Do not use tools to install the filter assembly. Install the filter fuel cup (2): Turn the filter fuel cup clockwise until the oil cup is locked in place against the stop block.
- 9) Bleed the fuel system.

1.7.4 Bleeding the fuel system

To avoid personal injury:

Do not bleed a hot engine, as this can cause fuel to spill on the hot exhaust manifold and cause fire hazard.

The fuel system needs to be bled under the following conditions:

- The fuel tank is empty or some fuel is discharged from the fuel tank.
- Disconnect the low-pressure fuel pipe.
- The low-pressure fuel system is leaking.
- Replace the fuel filter.
- Engine not used for a long time.

Perkins 1104D:

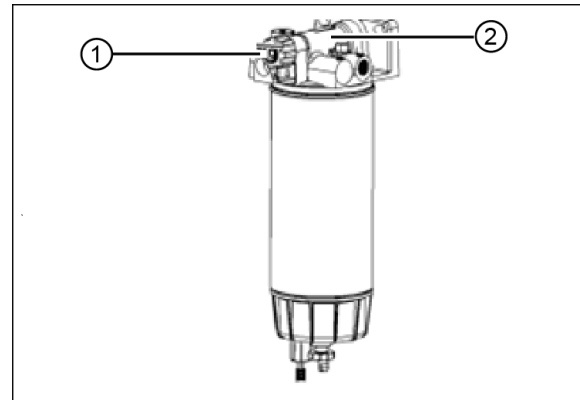

1. Check the fuel supply valve in the ON position (if equipped).

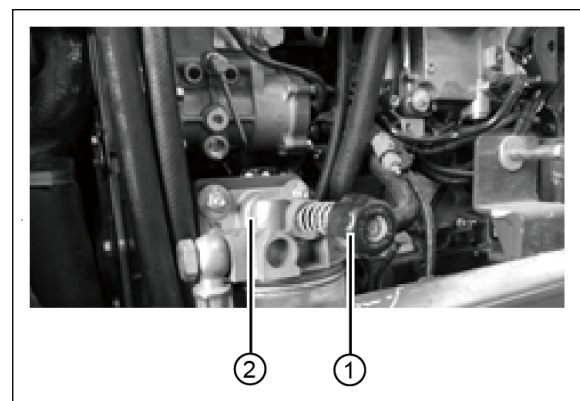



2. Press in and rotate the charge pump handle (1) counterclockwise to unlock it.



CAUTION: Press the handle (1)

repeatedly for filling. During filling, the manual pressure required for filling fuel system will increase.

3. Locking handle (1): Press in the handle and turn it clockwise to lock it.



CAUTION: Ensure that the filling

handle (1) is correctly locked in place. If the filling handle is not locked in place, the fuel to the fuel system will be blocked.

4. Start the engine and run it at idle speed for 5 minutes, and exhaust the air in the fuel system.
5. If the engine fails to start, repeat steps 2 to step 5.

1.7.5 Checking belt

In order to obtain the highest performance of the engine, check the belt for wear and crack. If the belt is worn or damaged, replace the belt.

Check the belt for cracks, splits, wear, grease, misalignment of the wire core and signs of liquid contamination.

Perkins 1104D:

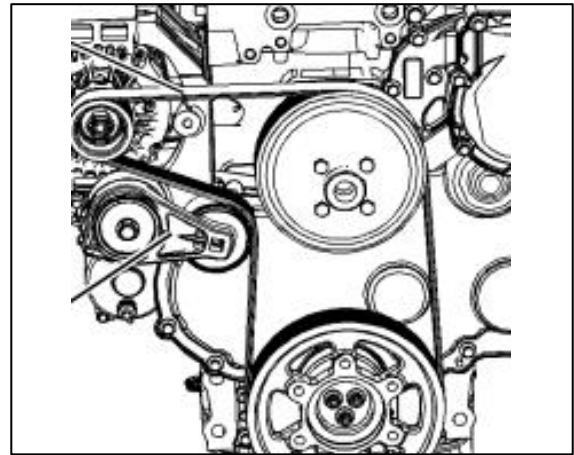

The belt must be replaced if the following conditions occur.

- There are cracks in at least two belt ribs.
- There is at least one segment of belt misalignment with a maximum length of 50.8 mm on one rib. Replace the belt,

Check the belt tensioner for looseness, damage, replace the belt tensioner if necessary.

1.7.6 Replacing filter element of hydraulic system

Replace every 500 hours or six months, whichever comes first.

It is necessary to change the hydraulic return filter element and hydraulic high-pressure filter element every 500 hours. Regular changing of filters is necessary for good machine performance and long service life. Dirty or blocked filter may cause the hydraulic component performance degradation, and continuous use may cause component damage. Extreme operating conditions require increased filter



replacement.

Retract the boom and park the machine on a level ground, shut down the engine.

Replace the hydraulic oil tank return filter element

- 1) Shut down the engine and release the pressure in the hydraulic system.

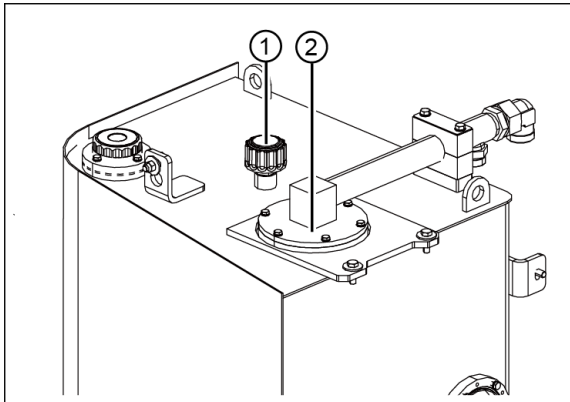

1. Breather
2. Oil return filter assembly

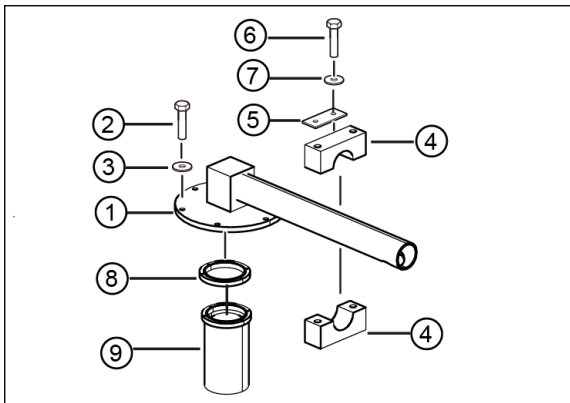

1. Oil return cover plate
2. Bolt
3. Washer
4. Pipe clamp
5. Press plate
6. Bolt
7. Washer
8. O-ring
9. Filter element

9. Return filter element
- 2) Remove the pipe clamp first, and then remove the oil return cover plate assembly.
- 3) Replace the filter element.
- 4) Reset to the original state.

1.8 Every 1000 hours

1.8.1 Replacing air filter element

Check the dust discharge valve every day, replace the cracked and deformed dust discharge valve, and clean the dust in it.

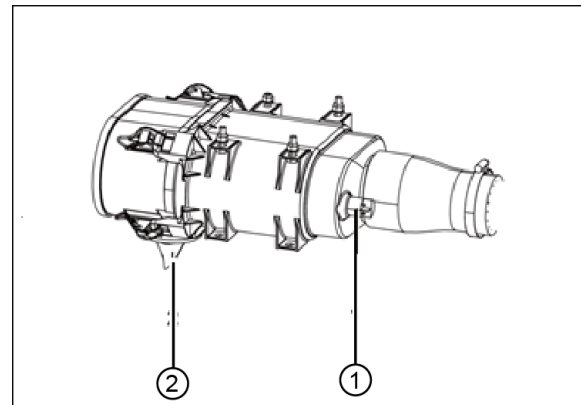

1. Electronic differential pressure sensor
2. Dust discharge valve

When the intake resistance reaches the maximum intake resistance of the engine, the main filter element shall be cleaned.

⚠ Perform this step when the engine is turned off.

Clean the air cleaner primary element

Clean the main filter element every 250 hours or when the air cleaner blocking alarm sounds or the maintenance indicator turns red.

The main filter element needs to be replaced only



when the air cleaner primary element is cleaned 5-6 times or the regular maintenance time is reached.

When replacing the main filter element, replace the safety filter element together.

It is forbidden to clean the safety filter element.

- 1) Turn off the engine and open the hood.
- 2) Remove the A/C filter element cover.
- 3) The radial sealed main filter element is tightly installed on the air outlet pipe. The removal of the filter element has a little resistance, so it is recommended to rotate the filter element while pulling it out to avoid knocking the housing and the filter element.

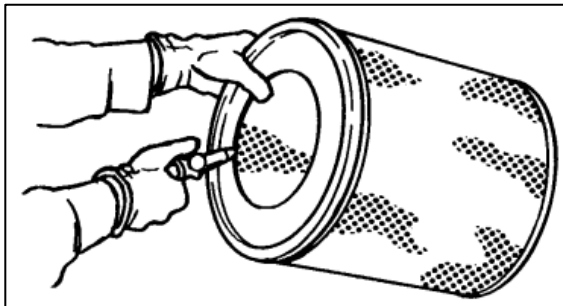

- 4) Clean the filter element from the inside out with a low pressure compressed air (up to 207Kpa) at least 30mm from the filter element.
- 5) When replacing the safety filter element, clean the inside of the air outlet pipe with a clean damp cloth and check the sealing surface for damage. Avoid the air inlet of the engine (i.e. the air cleaner outlet) exposed as much as possible. If there is no proper safety filter element, you can replace one

immediately.

- 6) Check whether new filter elements are in good condition, especially on the sealing surface and clean sides, and avoid installing damaged filter element. Do not wipe the sealing surface because the surface of the filter element is coated with a layer of lubricant to facilitate easier installation of the filter element.
- 7) If the safety filter element has just been replaced, it is necessary to confirm whether the safety filter element is installed correctly before the installation of the main filter element, then push the edge of the filter element by hand, carefully install the main filter element, and confirm that the main filter element is fully installed in the housing. The main filter element cannot be pushed in by the pressure of the end cap, which will damage the housing and the buckle. If the end cap cannot be installed in place due to the filter element, remove the end cap and continue to push in the main filter element to install the main filter element in place.
- 8) Check all fasteners including hoops, clamps, nuts and connections for tightening, check the pipeline for leaks, and repair them. Any leakage will cause dust to bypass the air cleaner and enter the engine directly, and finally reset the alarm indicator.



1.8.2 Replacing hydraulic oil tank breather

Park the machine on level ground and turn off the engine.

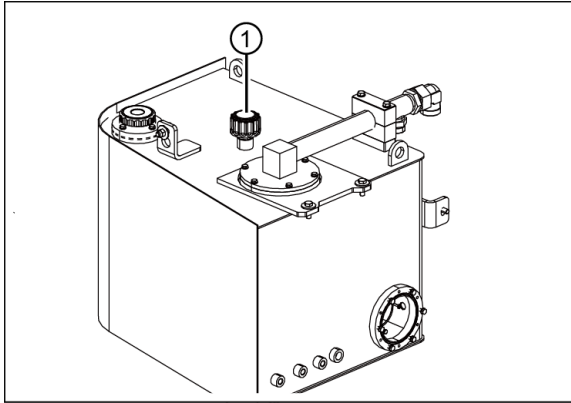

- 1) Remove the old breather and replace it with a new one.

1.8.3 Replacing the transmission fluid, transfer box oil and filter (If equipped)

First maintenance after 250 h, then maintain the vehicle every 1000 h.

Drain the transmission fluid

- 1) Stop the engine, park the machine on a level ground, set the gear selector to N gear, shut down the engine, pull up the parking brake handle, and chock the tire to prevent the machine from moving.

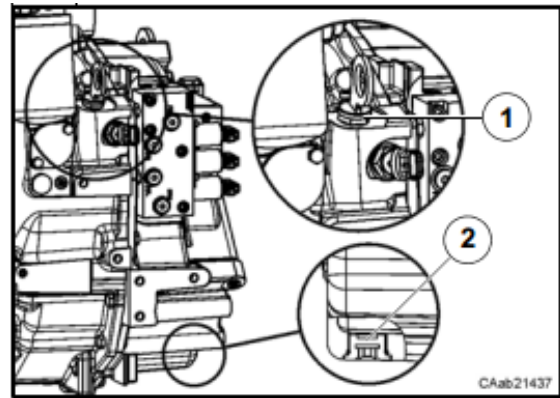

- 2) Place a suitable container under the drain plug (2), pull off the oil dipstick (1), unscrew the drain plug (2), drain all oil, clean carefully and assemble the plug (2).

! Danger of scalding at high

temperature: wear protective equipment and operate carefully to avoid personal damage.

Discharging transfer box oil

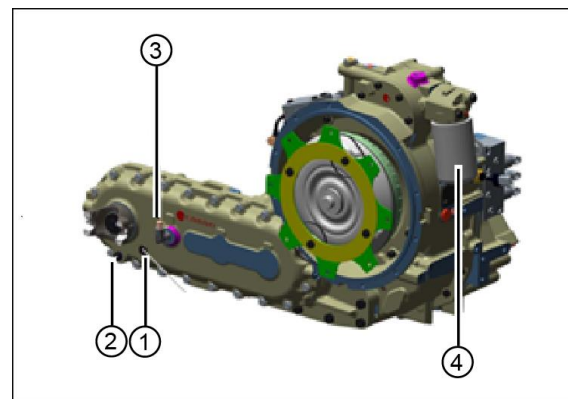

- 1) Place a suitable container under the drain plug (2), remove the oil filler plug (1) and drain plug (2), drain all oil, clean and install the plug (2).

No.	Description
1	Oil filler
2	Oil outlet
3	Breather



Replacing filter

- 1) Remove the filter and seal.
- 2) Clean the gasket contact surface of the mounting with a clean cloth.
- 3) Apply a clean layer of lubricating oil to the O-ring of the new filter.
- 4) Reinstall the new filter on the mounting.

Adding transmission fluid

- 1) Add the specified oil to the level between the max, and min. of the oil dipstick (1) (following the rules of reference range based on the transmission oil temperature), and check the oil level again after 5 minutes or add to the specified level if necessary.
- 2) Install the oil dipstick (1).

Adding the transfer box oil

- 1) Add the lubricating oil through the oil filler (1) to the lower edge of the oil filler, wait for 5 minutes, check the oil level again, and add it if necessary.
- 2) Install the upper oil filler plug.

1.8.4 Replacing transfer box oil (If equipped)

First maintenance after 250 h, then maintain the vehicle every 1000 h.

Stop the engine, park the machine on a level ground, set the gear selector to N gear, shut down the engine, pull up the parking brake handle, and

chock the tire to prevent the machine from moving.

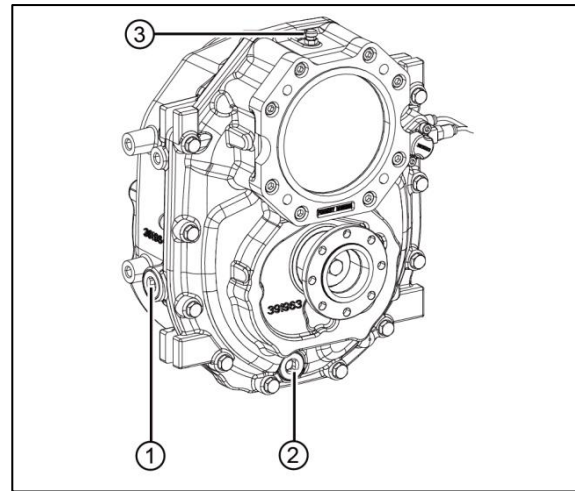

1. Oil filler \ Oil level sight glass

2. Oil outlet

3. Breather

- 1) Place a suitable container under the drain plug (2), remove the oil filler plug (1) and drain plug (2), drain all oil, clean and install the plug (2).
- 2) Add the lubricating oil through the oil filler (1) to the lower edge of the oil filler, wait for 5 minutes, check the oil level again, and add it if necessary.
- 3) Install the oil filler plug.

1.9 Every 1500 hours

1.9.1 Replacing the drive axle reducer oil

The first maintenance is 150h, and then the maintenance is carried out every 1500h.



Stop the engine, park the machine on a level ground, set the gear selector to N gear, pull up the parking brake handle, and chock the tire to prevent the machine from moving.

Replacing the drive axle final drive oil

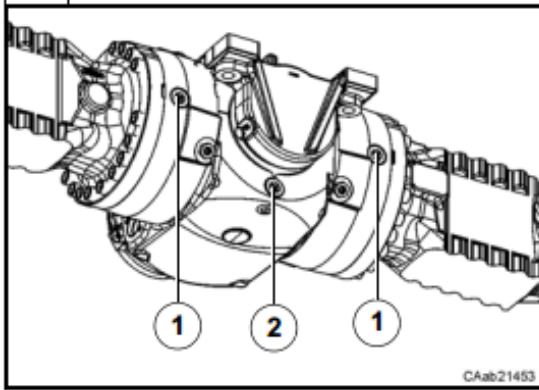

- 1. Filler plug
- 2. Drain plug

- 1) Place a suitable container under the drain plug (2), first remove the oil filler plug (1) and then remove the drain plug (2). Drain all oil. Install and tighten the drain plug (2).
- 2) Add the specified drive axle oil to the lower edge of the oil filler plug hole (1). Wait for 5 minutes, then check the oil level and add it to the specified level if necessary. Install and tighten the oil filler plug (1).

Replacing the drive axle wheel reducer oil

1. Turn the wheel so that the plug (4) is in the highest position and unscrew it to some extent to release the possible pressure.

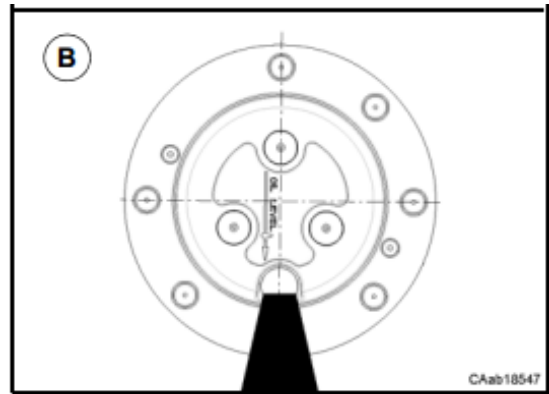

2. Rotate the wheel so that the drain plug is in the lowest position and place a suitable container underneath. Remove the screw plug and drain oil.

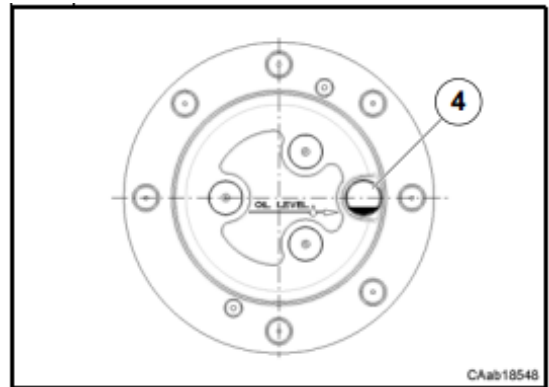

3. Turn the wheel so that the plug (4) is in a horizontal position. Add the specified oil to the lower edge of the filling hole.
4. Tighten the plug.

1.10 Every 2000 hours

1.10.1 Replacing coolant

The coolant in the cooling system shall be completely replaced every 2000 working hours or two years (whichever comes first). Before that, if the coolant is contaminated, the engine is overheated or the radiator is foamed, it should be replaced in advance.

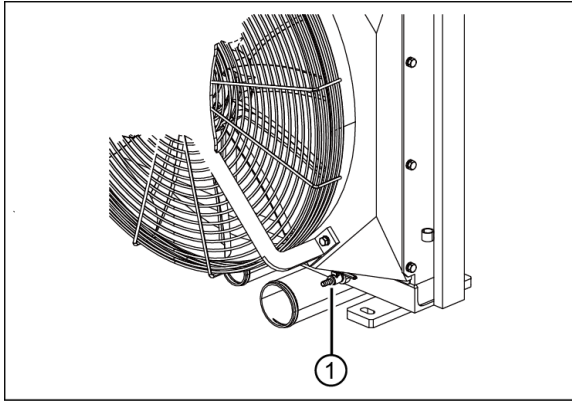

2. Outlet of radiator coolant

- 1) Close the engine and allow it to cool.
- 2) Remove the coolant filler cap from radiator.
- 3) Open the water drain valve of the radiator and the drain valve of the engine coolant (if equipped) as well as the coolant drain valve of the transmission (if equipped), discharge the coolant and hold it with a container.
- 4) After the engine and transmission coolant is drained thoroughly, close the drain valve (if equipped) for radiator, engine and transmission.
- 5) Check all water pipes and clamps of cooling system for damage and replace them if necessary. Check the water radiator for leakage, damage and dirt accumulation, and clean and repair it as required.
- 6) Fill slowly by the filler until the maximum allowable level of the Radiator.
- 7) Install the coolant filler cap.
- 8) Run the engine at idle speed, check for level and leakage, and refill if necessary.

1.10.2 Checking boom chain for wear

Chain wear can occur in the following locations

- On the joint, resulting in chain elongation.
- By contact with the pulley, on the edge of the connecting plate.
- By contact with the belt pulley flange, on the surface of the plate and extension pin.
- On the plane where the extension pins are aligned.

Check Chain elongation



It is recommended to do this with a Chain check gauge.

- 1) Raise the Outrigger (If equipped with outrigger) to keep the Boom level.
- 2) Fully extend the Boom and continue for a few minutes to properly tension the Chain.
- 3) Since the chain may wear unevenly over its length, split the chain into 4 aliquots and check with a gauge at the center of each section.
- 4) Chain specification varies with model. Below are some models' chain specifications.

Model	Spec	Pitch	Width	Thickness
H1840	BL588	15.875	42.2	15
	BL866	25.4	52.2	24.1

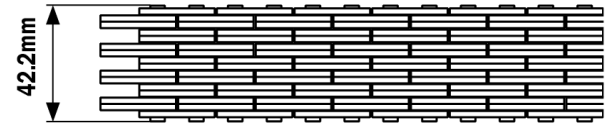
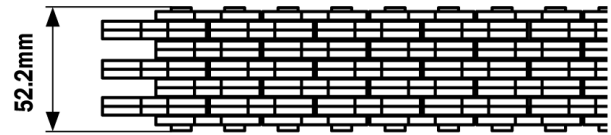
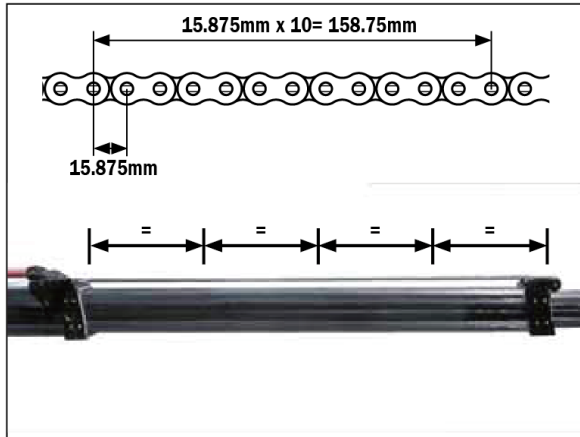
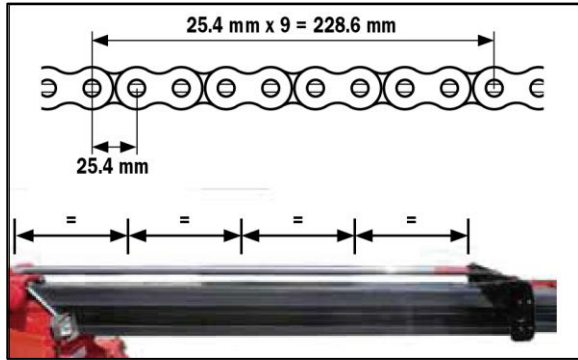

! CAUTION: If the size is less than the minimum size ($52.2 \text{ mm} - 52.2 \times 2\% = 51.156 \text{ mm}$; $42.2 \text{ mm} - 42.2 \times 2\% = 41.356 \text{ mm}$), replace the chain.

In addition to wear, the high pressure between the side plate and the pulley may cause joint jamming.

In this case, a pair of chains should also be replaced.

Extension pin plane alignment

Check the entire chain.

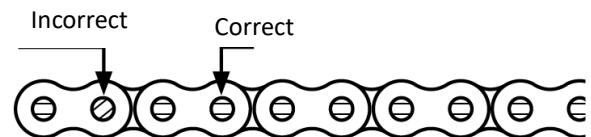

The friction between the plate and the extension pin may cause the pin to rotate in the outer plate, thus resulting the pin falling off the housing.

! CAUTION: If the plane is not aligned longitudinally with the chain, replace it with a pair of chain.

! CAUTION: If the maximum size is exceeded ($228.6 \text{ mm} + 228.6 \times 2\% = 233.2 \text{ mm}$; $158.75 + 158.75 \times 2\% = 161.925$), replace a pair of chain.

Check the side steel plate for wear

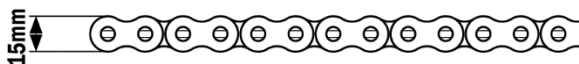
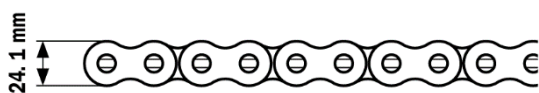

! CAUTION: If the size is less than the minimum size ($24.1 \text{ mm} - 24.1 \times 2\% = 23.618 \text{ mm}$; $15.5 \text{ mm} - 15.5 \times 2\% = 15.19 \text{ mm}$), replace the chain.

Extension pin wear

1.10.3 Replacing hydraulic oil

It is required to be replaced every 2000 h or every two years, whichever comes first.

Before replacing the hydraulic oil, a hydraulic oil



test can be performed to confirm whether it is necessary to replace it. If the hydraulic oil is not replaced during the 2000 h test, the hydraulic oil is tested quarterly. Replace the hydraulic oil until the test fails.



CAUTION: The hydraulic suction filter should be replaced when the hydraulic oil is replaced.

Park the vehicle on the level ground so that the vehicle is in the storage position.

- 1) Close the ball valve located on the hydraulic oil tank (if equipped with ball valve).



Danger of component damage. Do not start the engine when the hydraulic oil tank ball valve is closed, otherwise the components will be damaged. If the ball valve is turned off, take the key from the key switch and hang a warning sign on the device.



Danger of physical injury. The splashed hot oil can penetrate and burn the skin.

- 2) Remove the drain plug from the hydraulic oil tank.
- 3) Drain the hydraulic oil from the hydraulic oil tank completely into a suitable container. To speed up the oil drain, open the oil tank filler cap.

- 4) Remove the suction filter from the hydraulic oil tank.
- 5) Flush the inside of the hydraulic oil tank with a mild solvent. (Clean one side with chemical cleaning agent first. After drying, rinse with clean hydraulic oil to release cleaning oil.)
- 6) Clean the foreign matter absorbed by the ring magnet.
- 7) Install a new suction filter.
- 8) Install the upper drain plug.
- 9) Add the hydraulic oil to the hydraulic oil box until it reaches 1/2 level of the observation meter. No overflow is allowed. Wipe and wash off Hydraulic oil that may splash out.
- 10) Open the Ball valve on the Hydraulic oil tank (if equipped with Ball valve).



CAUTION: When installing drain plug and filter, please be sure to use pipe thread sealant.

- 11) Check all functions of the machine and check for oil leakage through one full cycle.
- 12) After a working cycle, recheck the level of the fuel tank and add oil to the 1/2 of the tank. It is strictly prohibited for the oil to overflow.

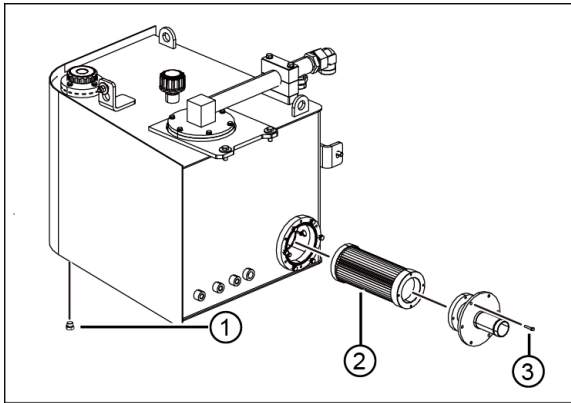

No.	Name
1	Drain plug
2	Suction filter
3	Connecting bolt of suction oil flange and tank



1.11 Appendix

1.11.1 Maintenance instructions

1. General instructions

Before starting the Telescopic handler, ensure that the area is well ventilated.

Wear suitable clothes and avoid jewelry and loose and comfortable clothes. If necessary, tie and protect your hair.

If necessary, stop the engine and remove the ignition key.

Read the operation manual carefully.

Carry out all repairs immediately, even if the relevant repairs are minor.

Repair all leaks immediately, even if the relevant leaks are small.

Ensure that old materials and spare parts are handled in a completely safe and ecological manner.

Be careful of the danger of burning and splashing (exhaust, radiator, internal combustion engine, etc.).

2. Lubricating oil and fuel

Use the recommended lubricating oil (never use contaminated lubricating oil).

Never fill the primary fuel filter element while the engine is running.

Fill the primary fuel filter element only in the area specified for this purpose.

Never fill the fuel tank to the upper limit.

When the fuel tank is open or being filled, do not smoke or use flames around the telescopic handler.

3. Hydraulic system

Do not attempt to loosen joints, hose or any hydraulic component while the circuit is under pressure.

 **Balance valve: It is dangerous to change and remove balance valve or safety valves that may be installed on telescopic handler cylinder. These operations can only be performed by approved technicians.**

 **Hydraulic accumulator: These hydraulic accumulator that may be installed on the telescopic handler are pressurized devices. Disassembling these accumulators and their piping systems is a dangerous operation and must be performed by an approved technician.**

Release the accumulator pressure of the brake system before service: park the



machine on solid level ground, retract the boom to the stowed position, stop the engine, and place pads under the wheels. Repeatedly press and release the travel brake pedal (foot brake); repeatedly pull and release the parking brake handle (hand brake).

4. Electrical system

Never Short circuit the starter to start the Engine. If the forward / N gear / reverse selector is not in the position of N gear and the parking brake is not engaged, the Telescopic handler may move abruptly.

Do not touch the battery with metal objects.

Disconnect the battery before operating the circuit

5. Welding operation

Disconnect the battery before performing any welding operations on the telescopic handler.

Do not perform welding work on the assembled tire, which will increase the pressure and cause the tire to explode.

Disconnect the electronic control unit to avoid irreparable damage to electronic components.

6. Cleaning vehicle

Close and lock all doors, windows, etc.

Avoid contacting with joints, electrical components and connectors during cleaning.

If necessary, prevent water, steam or detergent from entering vulnerable parts, especially electrical components.

7. Use of safety support

Safety support instructions

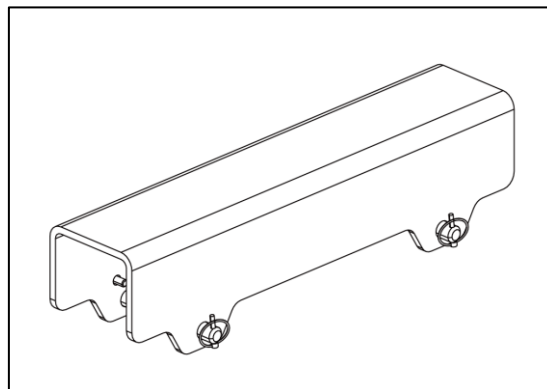

Boom safety support

The telescopic handler is equipped with safety support, which must be installed on the lift cylinder



connecting rod when working in the area below the boom.

The installation of safety support

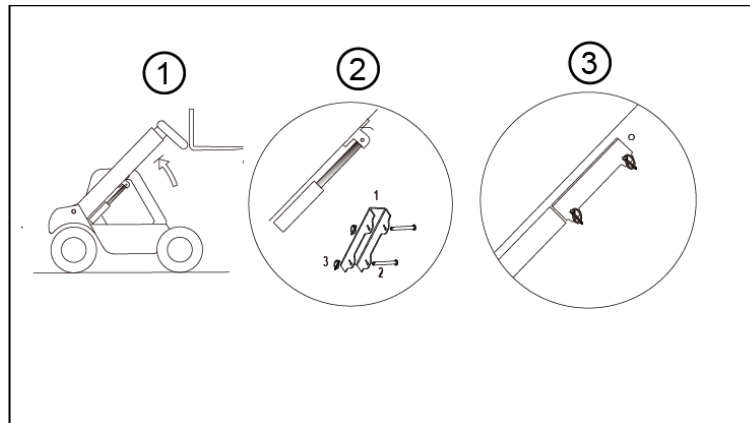

- 1) Fully raise the boom.
- 2) Fit the safety support on the lift cylinder connecting rod and secure it with axis pin.
- 3) Slowly lower the boom and stop before coming into contact with the safety support.

Remove the safety support

- 1) Fully raise the boom.
- 2) Remove the axis pin.
- 3) Put the safety support back in place.



1.11.2 Maintenance List

H1840

H1840 (H18040000P3N1000) (EU stageIII-Perkins 1104D engine) Maintenance List							
Maintenance Period	Material code	Name		Specification	Unit	Q'TY	Remark
50h	5301000045	Engine oil	Engine oil	CH-4 15W/40	Liter (L)	8.5	Engine (The oil filling amount is subject to the oil level gauge)
	4110703313001	Oil filter element	FILTER	2654407	SET	1	
150h	5301000361	Gear oil	Gear oil	SAE J306: 75W-80	Liter (L)	21.2	Final drive: 8L; Single-side wheel reducer: 1.3L
250h	5301000361	Gear oil	Gear oil	SAE J306: 75W-80	Liter (L)	21.75	1. Transmission: Power shift part: 20L; Drive part: 1.75 L
	4110703302001	Transmission fluid filter	Oil filter	40701	SET	1	
500h	5301000045	Engine oil	Engine oil	CH-4 15W/40	Liter (L)	8.5	Engine (The oil filling amount is subject to the oil level gauge)
	4110703313001	Oil filter element	FILTER	2654407	SET	1	
	4110703313002	Primary fuel filter element	FILTER	4395038	SET	1	
	4110703313003	Secondary fuel filter element	FILTER	3611274	SET	2	
	4120706735	Return filter	FILTER	TL368E/5	SET	1	Hydraulic system
1000h	4110703313001	Oil filter element	FILTER	2654407	SET	1	Engine (The oil filling amount is subject to the oil level gauge)
	5301000045	Engine oil	Engine oil	CH-4 15W/40	Liter (L)	8.5	
	4110703313002	Primary fuel filter element	FILTER	4395038	SET	1	
	4110703313003	Secondary fuel filter element	FILTER	3611274	SET	2	
	4120706735	Return filter	FILTER	TL368E/5	SET	1	Hydraulic system
	4120002915	Air breather	FILTER	D-G3/4	SET	1	
	4190001459	A/C filter element Safety filter element	FILTER	P780523	SET	1	
	4190001460	Air cleaner primary element	FILTER	P780522	SET	1	
1250h	5301000361	Gear oil	Gear oil	SAE J306: 75W-80	Liter (L)	21.75	1. Transmission: Power shift part: 20L; Drive part: 1.75 L



Maintenance Manual

	4110703302001	Transmission fluid filter	Oil filter	40701	SET	1	Transmission
1500h	4110703313001	Oil filter element	FILTER	2654407	SET	1	Engine (The oil filling amount is subject to the oil level gauge)
	5301000045	Engine oil	Engine oil	CH-4 15W/40	Liter (L)	8.5	
	4110703313002	Primary fuel filter element	FILTER	4395038	SET	1	
	4110703313003	Secondary fuel filter element	FILTER	3611274	SET	2	
	4120706735	Return filter	FILTER	TL368E/5	SET	1	Hydraulic system
1650h	5301000361	Gear oil	Gear oil	SAE J306: 75W-80	Liter (L)	21.2	1. Final drive: 8 L; Single-side wheel reducer: 1.3 L;
2000h	4110703313001	Oil filter element	FILTER	2654407	SET	1	Engine (The oil filling amount is subject to the oil level gauge)
	5301000045	Engine oil	Engine oil	CH-4 15W/40	Liter (L)	8.5	
	4110703313002	Primary fuel filter element	FILTER	4395038	SET	1	
	4110703313003	Secondary fuel filter element	FILTER	3611274	SET	2	
	4190001459	A/C filter element Safety filter element	FILTER	P780523	SET	1	Air cleaner, clean every 250h; Clean 4-5 times
	4190001460	Air cleaner primary element	FILTER	P780522	SET	1	Replace.
	4120001706	Suction filter	FILTER	WU-630*100F -J	SET	1	When replacing the hydraulic oil, replace
	4120706735	Return filter	FILTER	TL368E/5	SET	1	Hydraulic system
	4120002915	Air breather	FILTER	D-G3/4	SET	1	



1.11.3 Selection of oils

Type	Recommended types and standards	Oil parts
Engine oil API CH-4	Lowest ambient temperature $\geq -10^{\circ}\text{C}$,SAE 15W-40	Engine (EU StageIII engines)
	Lowest ambient temperature $< -10^{\circ}\text{C}$, SAE 10W-30	
Engine oil API CJ-4	Lowest ambient temperature $\geq -10^{\circ}\text{C}$, SAE 15W-40	Engine (EU Stage V engines)
	Lowest ambient temperature $< -10^{\circ}\text{C}$, SAE 10W-30	
Gear oil	API GL-4, SAE 75W or API GL-4, SAE 80W-90	Axle
	Mobil fluid 424	
Gear oil	API GL-4, SAE 75W	Transmission. Transfer box
	Mobil fluid 424	
Gear oil	L-CKD 220	Slewing reducer (If equipped)
Hydraulic oil	Minimum temperature $> -25^{\circ}\text{C}$, L-HV46 low temperature hydraulic oil	Hydraulic oil tank
	$-40^{\circ}\text{C} < \text{minimum temperature} \leq -25^{\circ}\text{C}$, L-HS32 ultra-low temperature hydraulic oil	
	Minimum air temperature $\leq -40^{\circ}\text{C}$, 10 aviation hydraulic fluid	
Fuel	Ambient temperature $\geq 4^{\circ}\text{C}$, No. 0 Light diesel fuel	Fuel tank EN590 and ASTM D975 ULSD
	Ambient temperature $\geq -5^{\circ}\text{C}$, -No. 10 Light diesel fuel	
	Ambient temperature $\geq -14^{\circ}\text{C}$, -No. 20 Light diesel fuel	
	Ambient temperature $\geq -29^{\circ}\text{C}$, -No. 35 Light diesel fuel	
Grease	No. 2 or No. 3 lithium-based grease Molybdenum disulfide	Working device hinge point axis pin
	KunLun HP-R high temperature grease	Boom slider
Antifreeze	Antifreeze -25°C ethylene glycol content 40%	Cooling system
	Antifreeze -35°C ethylene glycol content 50%	
	Antifreeze -45°C ethylene glycol content 60%	
Diesel exhaust fluid (DEF)	ISO22241-1, urea content 32.5%	DEF tank (If equipped)
Air conditioner	R134a	



1.11.4 Maintenance items

Maintenance item	Operation content	Maintenance level						
		Every day	Weekly	Quarterly	Every six months	Every year		
		8h	50h	250h	500h	1000h	2000h	
Engine	Check engine oil level	•						
	Check the coolant level	•						
	Check the fuel level	•						
	Check the DEF level (If equipped)		•					
	Check the primary fuel filter	•						
	Clean radiator core		•					
	Replace engine oil and filter				•			
	Discharge the water and impurities from the primary fuel filter	Perkins engines(Every day or every 8h);Kubota engines(Every week or every 50h)						
	Replace the secondary fuel filter element				•			
	Replace the primary fuel filter element				•			
	Replace crankcase breather filter element (if equipped)				•			
	Clean the fuel tank					•		
	Replace air cleaner primary element					•		
	Replace air cleaner safety filter element					•		
	Replace the coolant						•	
	Tighten cooling pipe clamp			•				
	Tighten intake pipe hose			•				
	Check air cleaner maintenance indicator		•					
	Clean air cleaner dust cup	•						
	Check generator and fan belt tension			•				
Check engine fan clearance and drive Belt			•					
Check electrical components and electronic control system wiring harness		•						
Clean the DEF filler filter. (If equipped)						•		



Maintenance Manual

Maintenance item	Operation content	Maintenance level						
		Every day	Weekly	Quarterly	Every six months	Every year		
		8h	50h	250h	500h	1000h	2000h	4000h
	Replace the DEF manifold filter. (If equipped)						•	
	Replace the DEF pump filter. (If equipped)							•
Transmission	Check transmission fluid level			•				
	Replace the transmission lubricating oil (at least once a year)					•		
	Replace the transmission filter					•		
Front axle	Check the final drive and the wheel reducer oil level			•				
	Replace the final drive lubricating oil (at least once a year)	The first maintenance is 150h, and then the maintenance is carried out every 1500h.						
	Replace wheel reducer lubricating oil (at least once a year)	The first maintenance is 150h, and then the maintenance is carried out every 1500h.						
	Check tire pressure	•						
	Check the fixing of wheel nut	•						
	Clean oil breather			•				
Rear axle	Check the final drive and the wheel reducer oil level			•				
	Replace the final drive lubricating oil (at least once a year)	The first maintenance is 150h, and then the maintenance is carried out every 1500h.						
	Replace wheel reducer lubricating oil (at least once a year)	The first maintenance is 150h, and then the maintenance is carried out every 1500h.						
	Check tire pressure	•						
	Check the fixing of wheel nut	•						
	Clean oil breather			•				
Slewing mechanism	Check slewing reducer oil level (If equipped)			•				
	Slewing bearing lubrication (If equipped)		•					
Drive shaft	Retighten the propeller shaft bolt		•					
	Check the connection and wear of propeller shaft		•					
	Universal joint lubrication		•					
	Propeller shaft lubrication		•					
Cab	Check the action of the wiper	•						



Maintenance Manual

Maintenance item	Operation content	Maintenance level						
		Every day	Weekly	Quarterly	Every six months	Every year		
		8h	50h	250h	500h	1000h	2000h	4000h
	Clean the cab A/C filter		•					
	Replace the cab A/C filter			•				
	Check the washer fluid level		•					
	Check whether the throttle adjustment, brake joystick, the travel and operation of the variable-speed joystick are flexible	•						
	Check the seat belt	•						
	Check the coolant level and the fuel level of the water heater in the cab (if equipped)	•						
Boom	Check boom chain wear			•				
	Check boom padding block wear				•			
	Boom and padding block lubrication			•				
Electrical system	Check the operation of electrical system (signal lamps, headlamps, warning lamps, wiper, heating and ventilation devices)			•				
	Check the fixing of the battery terminal, and apply grease to the electrodes					•		
	Check the working condition of the instrument	•						
	Check the condition of wiring harnesses and cables					•		
	Check the starter and alternator							
Steering system	Check the function of the steering system	•						
Hydraulic system	Check hydraulic oil level	•						
	Replace return filter element				•			
	Replace the high-pressure filter element (if equipped)				•			
	Replace the hydraulic oil tank breather					•		
	Check the working conditions of the hose and cylinder					•		
	Replace the brake accumulator	Replace once every 5 years						



Maintenance Manual

Maintenance item	Operation content	Maintenance level						
		Every day	Weekly	Quarterly	Every six months	Every year		
		8h	50h	250h	500h	1000h	2000h	4000h
	filter (if equipped)							
	Clean hydraulic oil tank						•	
	Replace hydraulic oil						•	
	Replace suction filter						•	
	Check hydraulic circuit pressure						•	
	Check hydraulic circuit output						•	
Brake system	Check brake system pressure						•	
	Adjust brake						•	
	Check brake pads and brake discs for wear							•
	Check the clearance of the front and rear axle reducers							•
Complete vehicle	Check the fork wear				•			
	Fill each propeller shaft with grease		•					



1.11.5 Engine DTC

Perkins 904J:

S/N	DTC	Description	Impact on the machine			
			Engine does not start	Low power	Engine speed decreases	Engine shutdown
1	111	No. 1 Fuel injector fault	√	√		
2	112	No. 2 Fuel injector fault	√	√		
3	113	No. 3 fuel injector fault	√	√		
4	114	No. 4 fuel injector fault	√	√		
5	133	Intake manifold air temperature sensor fault	√			
6	141	Main engine speed/timing sensor fault			√	
7	142	Auxiliary engine speed/timing sensor fault				
8	143	Engine timing calibration fault	√			
9	144	Engine operation mode selector switch fault		√		
10	151	Intake pressure sensor		√		
11	154	Throttle position sensor fault			√	
12	155	Auxiliary throttle position sensor fault			√	
13	157	Engine oil pressure sensor fault		√		
14	159	Fuel rail pressure sensor failure		√		
15	162	Fuel rail pressure solenoid valve failure		√	√	
16	168	Engine coolant temperature sensor fault				
17	169	Low engine coolant				√
18	177	Turbine exhaust bypass valve actuator fault			√	
19	185	High exhaust temperature		√		
20	197	Intake manifold supercharging fault		√		
21	199	Glow plug starter relay fault				
22	233	Ether injection control solenoid valve				
23	245	Idle effective switch 1				
24	246	Idle effective switch 2				
25	253	Engine oil supply pump relay				
26	415	Software mismatch			√	√



Maintenance Manual

27	426	Machine security module					
28	429	Ignition key switch fault					
29	511	ECM supply voltage fault	√	√			
30	514	SAE J1939 data link failure			√		
31	516	5V sensor DC power supply fault		√		√	
32	517	8-volt sensor DC power supply failure		√			
33	527	Customer/system parameter failure		√	√		
34	551	No fault detected by the system					



1.11.6 Lubrication points indication

Lubrication point of the whole machine:

1. If work time is less than 50 h per week, then maintain it once a week.
2. If work continuously for a long time, the lubrication period is reduced to every 10 hours or every day.

No.	Location	Clockwise rotation joystick
1	Boom hinge lubrication point	2
2	Lower leveling cylinder lubrication point	2
3	Luffing cylinder lubrication point	2
4	Large roller axis pin lubrication point	2
5	Small roller axis pin lubrication point	1
6	Elevated flat cylinder lubrication point	2
7	Rotating lubrication point of auxiliary rack	2
8	Double axis pin lubrication point	1
9	Nylon axis pin shaft lubrication point	1
10	Body leveling cylinder lubrication point	2
11	Front outrigger cylinder lubrication point	4
12	Front outrigger swing lubrication point	2
13	Tire steering lubrication point	8
14	Swing lubrication points of front and rear axles	4
15	Propeller shaft lubrication point	6





1.11.7 Hydraulic schematic diagram

H1840 Hydraulic schematic diagram

