

AS0812E AERIAL WORK PLATFORM PARTS CATALOG



LINGONG GROUP JINAN HEAVY MACHINERY CO., LTD.

Spare parts and services

For the owner of the machines of LGMG, only the spare parts and services of LGMG can make your machine to better maintain the original features.

Only LGMG is able to provide you with the perfect match of pure quality spare parts for your machine and knowledge of professional maintenance staff. Only in this way it can ensure sustainable high productivity and longer service life.

AS0812E AERIAL WORK PLATFORM PARTS CATALOG

2014-11 Version 1 Printed 1

LINGONG GROUP JINAN HEAVY MACHINERY CO., LTD.

Add: Zhongrun Century Square, No. 13777, Jingshi Road, Lixia, Jinan, Shandong, P.R. China

Tel: 86-0531-81663345

Fax: 86-0531-81666853

Web: WWW.LGMG.COM.CN

FOREWORD

This parts catalog of AS0812E aerial work platform is made for the convenience of users to use, repair and maintain the machine, which can be referred in the process of using. It can also help the users to be familiar with the structure and assembly relation of the machine. Parts of the engine are showed in details in its structure handbook, which are no longer contained in the catalog.

The catalog identifies drawings and assembly relations of different parts according to the system. Components which can not be taken apart, such as welding parts or riveted assemblies, are marked only by their code without the list of their consisting parts. The list in the catalog is arranged in Chinese and English.

This catalog is based on the AS0812E standard product, which can be a reference for the other nonstandard products, for more information, please consult LGMG, the local dealer or LinGong website. With the advancement of technology, we will keep on improving the product, so some content in the catalog may be inconsistent with the future products, which will not notice the users. When ordering the spare parts, please be kindly inform us the manufacturing date and serial number of the machine.

THE COMPILER
2013.6

CONTENTS

B. Axle system	BoM Reference	Page
Front axle assembly	B0400-2504000002.S1B	8
Rear axle assembly	B0500-2505000235.S1B-1	10

D. Chassis system	BoM Reference	Page
Battery/tank side	D0800-2518000026.B	14
Tank side	D0802-2518000027.B	16
Battery side	D0801-2518000017.B1B	18
Chassis	D0700-2516002001.S1C	20
Right door assembly	D0702-2516000137.B1B	24
Left door assembly	D0701-2516000136.B1B	26
Pothole protection	D0900-2519000001.B	28
Right hollow protect	D0901-2519000026.S1B1	30
Left hollow protect	D0902-2519000027.S1B1	34
Pressing shaft assembly	D0900-2519000316.S	38

F. Steering system	BoM Reference	Page
Steering mechanism	F1200-2517000199.S	42

G. Scissor assy installation assembly	BoM Reference	Page
Scissor assy installation	G1300-2520003362.S1A	46
First inner arm assembly	G1300-2520003328.S3B	52

Inner arm	G1300-2520003277.S	54
Outer arm	G1300-2520003289.S	56
Inner arm	G1300-2520003294.S	58
Protective arm	G1300-2520000044.B2D	60
Wiring plate assembly	G1300-2520000130.B1A	62
Wiring plate assembly	G1300-2520000063.B1B	64

H. Swing system

	BoM Reference	Page
Counter weight assembly	H1600-2528000318.S1B	68

I. Cover accessory

	BoM Reference	Page
Covering accessory assembly	I1700-2529000586.S4C	72

K. Platform assembly

	BoM Reference	Page
Platform	K2100-2521006044.S1A	76
Platform assembly	K2100-2521003555.S1B	78
Extension platform assembly	K2100-2521004685.S1B	80
Roller assembly	K2100-2521003593.S2A	82
Rail assembly	K2100-2521003597.S	84
Semi-swing gate assembly	K2100-2521003556.S1A	86
Bracket	K2106-2521002803.S	88

L. Hydraulic system	BoM Reference	Page
Travel hydraulic assembly	L2300-2507000310.S1B1	92
Main valve st5158-ae00	L2300-4120704774	96
Filter	L2300-4120001128	98
Gear pump a101098620	L2300-4120001488	100
Steering hydraulic assembly	L2302-2507000337.S1A	102
Lifting hydraulic assembly	L2400-2508000217.S1H	104
Cable assembly	L2400-2508000157.S2A	108
Lifting cylinder	L2400-4120703496	110

M. Electric system	BoM Reference	Page
Electricity assembly	M2900-2530000976.S	114
Platform controller	M2900-4130001286	116
Ground control unit assembly	M2900-4130001287	118
Electricity assembly	M3100-2532001651.S	120
Bracket assembly	M3102-2532000039.B1C	128
Gear box	M3100-4130702145072	130
Input carrier assembly	M3100-4130702145073	132
Hub disassembly	M3100-4130702145074	134
Spindle assembly	M3100-4130702145075	136
Electric assembly	M3200-2533000681.S1B	138

B
AXLE SYSTEM



LINGONG GROUP JINAN HEAVY MACHINERY CO., LTD.

Front axle assembly

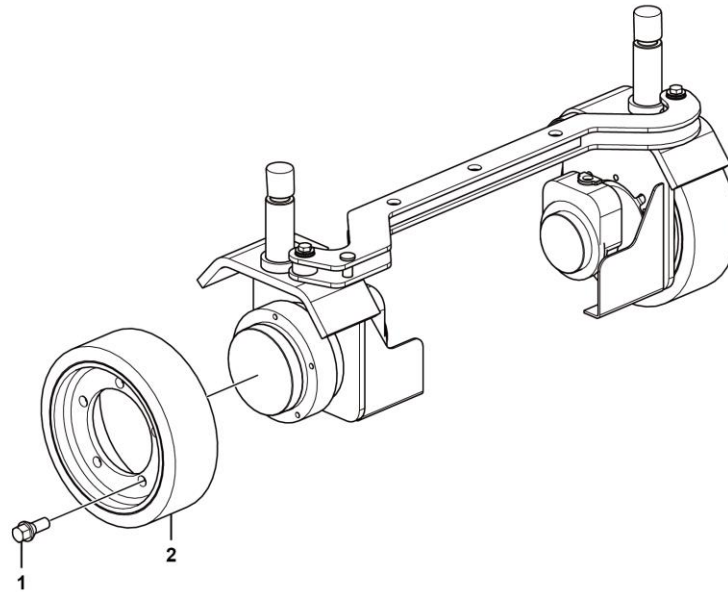

Rear axle assembly

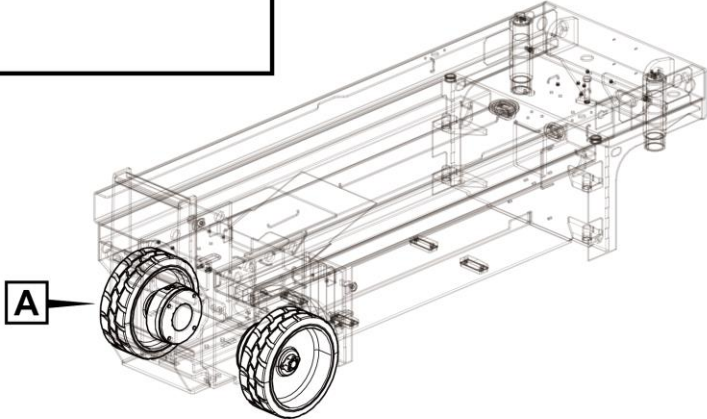
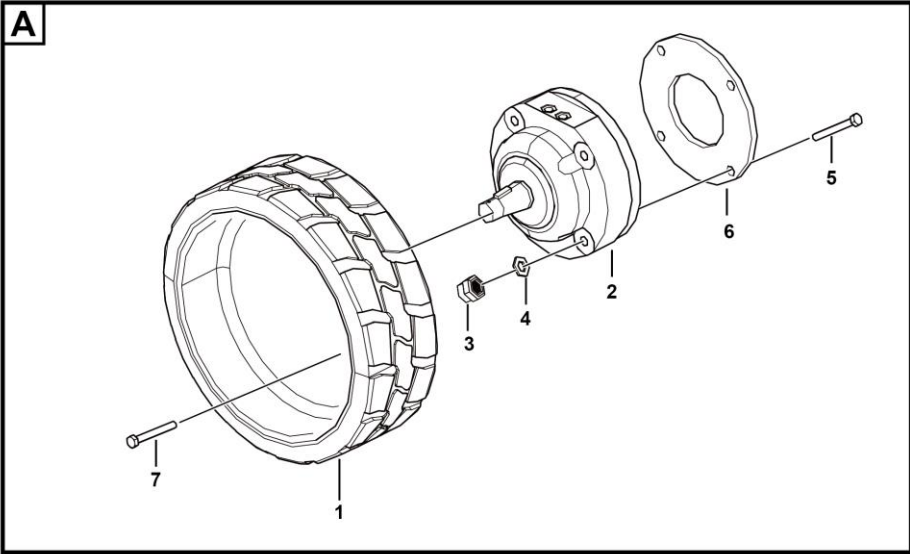

D
CHASSIS SYSTEM



LINGONG GROUP JINAN HEAVY MACHINERY CO., LTD.

Battery/tank side

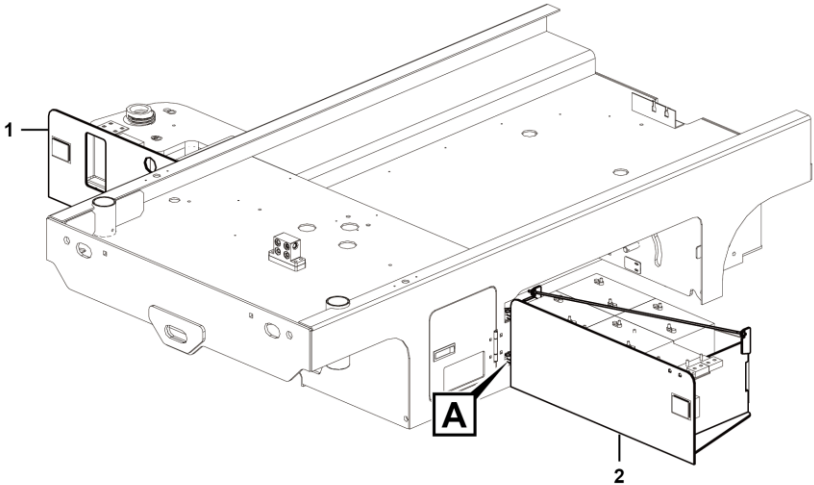
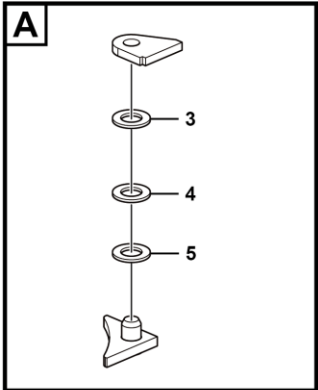

D0800-2518000026.B

Tank side

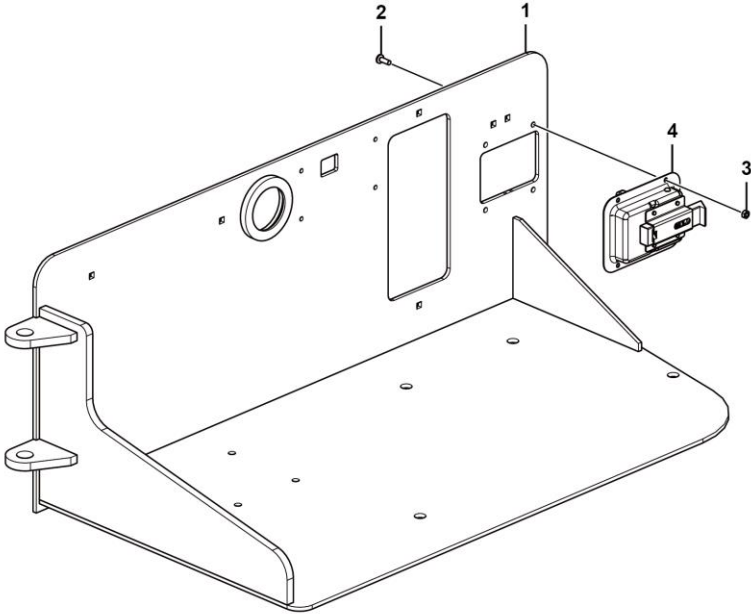

D0802-251800027.B

Battery side

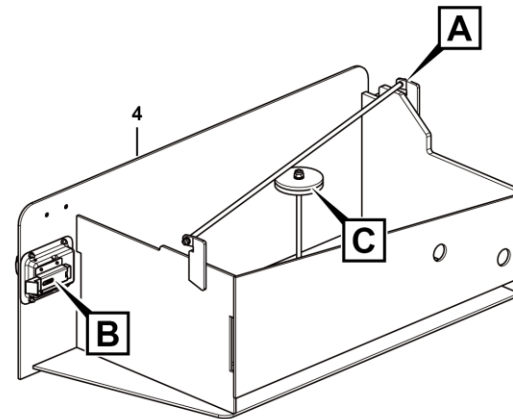
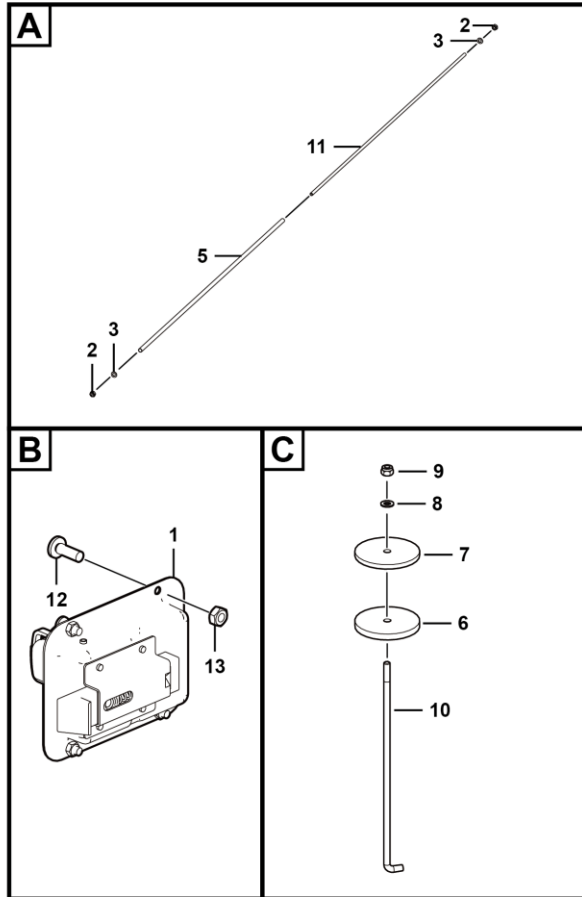

D0801-2518000017.B1b

Key	Part No.	Description	Spare parts Y/N	Qty	Remarks
1	4190001576	Latch ms866-27, left/right door	Y	1	
2	4013000028	Nut gb6170-m6epzn-8	Y	2	
3	4015000207	Washer gb97.1-6epzn-300hv	Y	2	
4	25180000025	Battery side	Y	1	
5	25180000212	Insulating sleeve, ϕ 7*700	Y	1	
6	25180004001	Rubber plate, fixing screw, battery side	Y	1	
7	25180004011	Pressure plate, fixing screw, battery side	Y	1	
8	4015000072	Washer gb97.1-8epzn-300hv	Y	1	
9	4013000210	Nut gb889.1-m8epzn-8	Y	1	
10	25180003392	Threaded rod, m8*25	Y	1	
11	25180000033	Threaded rod, m16*30	Y	1	
12	4014000114	Screw gb818-m5*14epzn-4.8	Y	4	
13	4013010029	Nut gb6170-m5epzn-8	Y	4	

Chassis

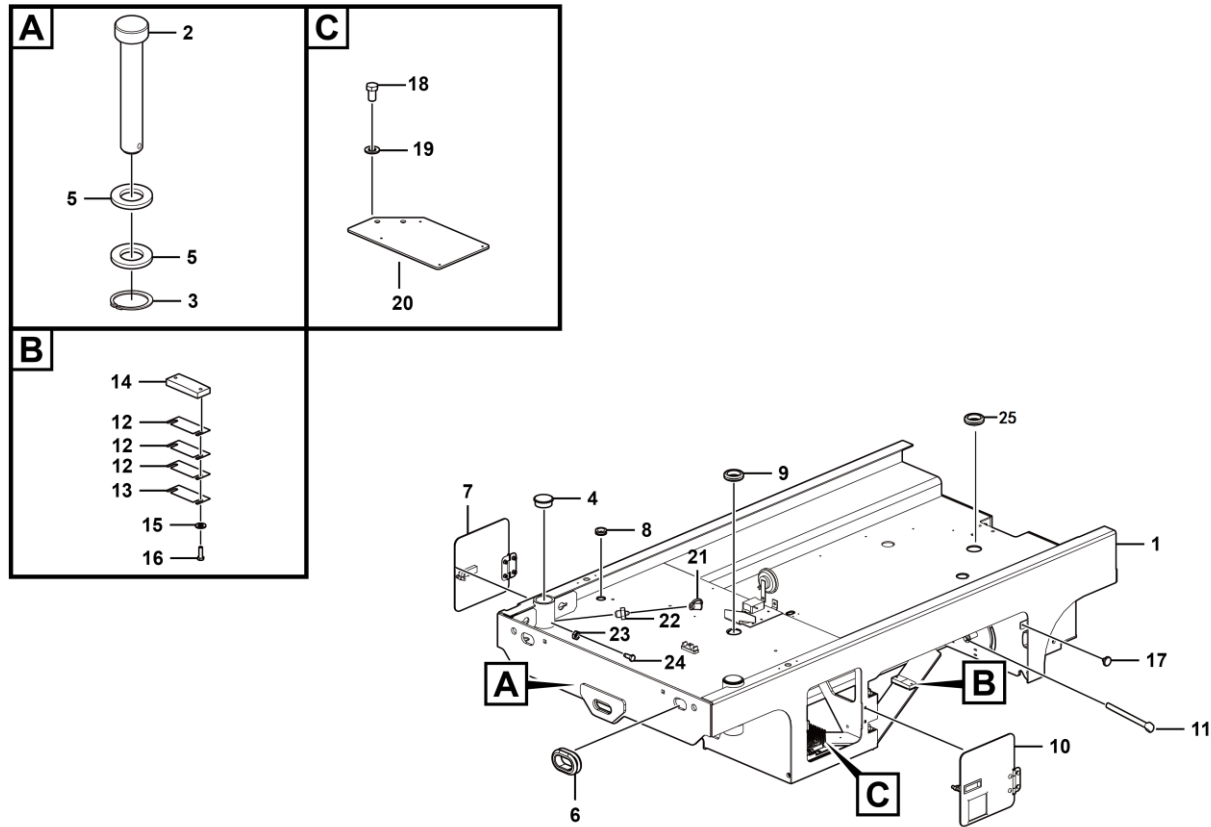

Key	Part No.	Description	Spare parts Y/N	Qty	Remarks
1	25160020022	Chassis assembly	Y	1	
2	25160001342	Cylinder pin, φ19.5*84	Y	1	
3	4015010295	Snap ring gb894.1-19flznyc-65mn-480	Y	1	
4	4190707077	Plug	Y	2	
5	4015010338	Washer gb97.1-20flznyc-300hv-480	Y	7	
6	25160000401	Rubber gromet, 30*36*12	Y	4	
7	25160001371	Weldment, right guard plate	N	1	
8	28219900091	Rubber gromet, 34*7	Y	2	
9	25160000621	Rubber gromet,88*5	Y	1	
10	25160001361	Weldment, right guard plate	N	1	
11	4016010136	Cotter pin gb91-4*45flznyc-480-q235a	Y	2	
12	25160000572	Shim,100*40*4.5*1	Y	6	
13	25160000611	Shim,100*40*4.5*2	Y	2	
14	25160000481	Cushion block, supporting battery and fuel tank side	Y	2	
15	4015010280	Washer gb97.1-8flznyc-480	Y	4	
16	4011010743	Bolt gb5783-m8*25flznyc-8.8-480	Y	4	
17	25200000402	Rubber plug,14*11	Y	2	
18	4011010978	Bolt gb5783-m12*30flznyc-8.8-480	Y	2	
19	4015010340	Washer gb97.1-12flznyc-300hv-480	Y	2	
20	25160001003	Forming (stamping, etc.)	Y	1	
21	4030000107	Oil bowl dust cap jxhf-00006	Y	2	
22	4030000065	Grease fitting jb7940.1-m10*1	Y	2	

Chassis

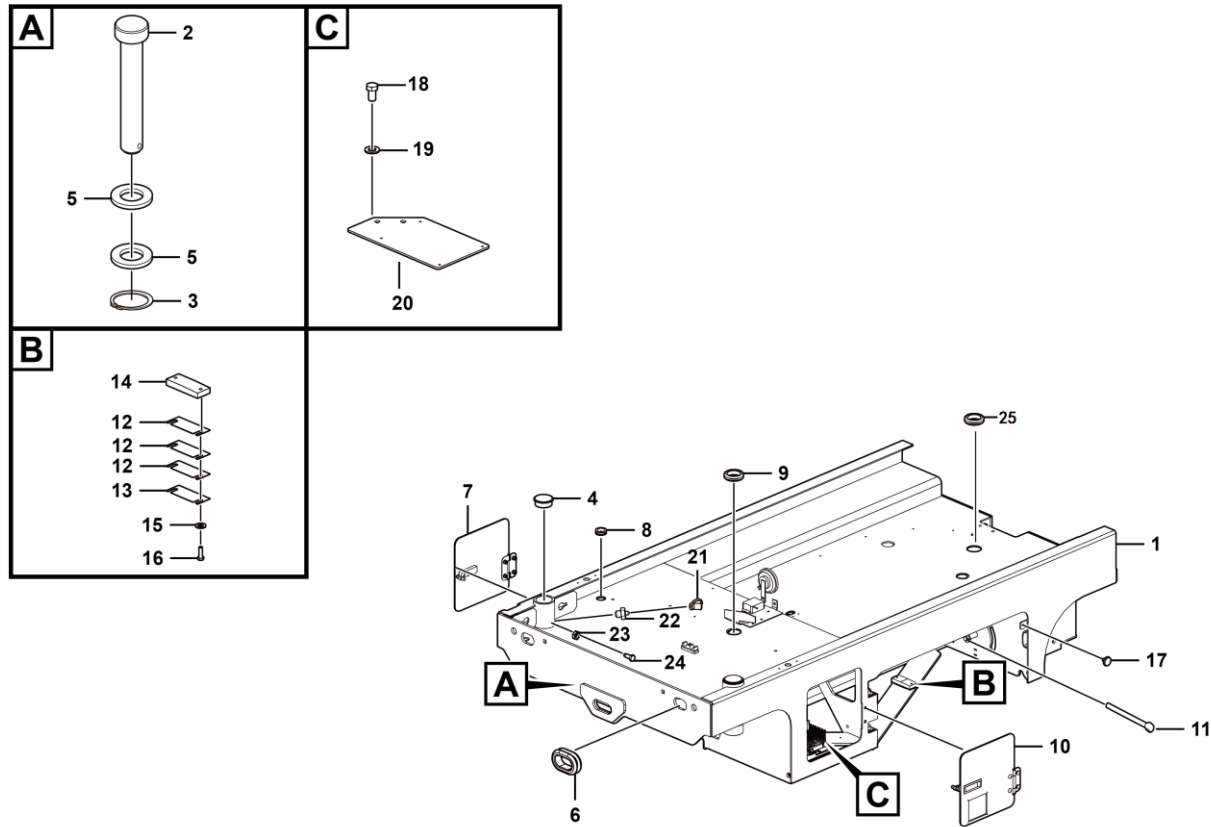

Right door assembly

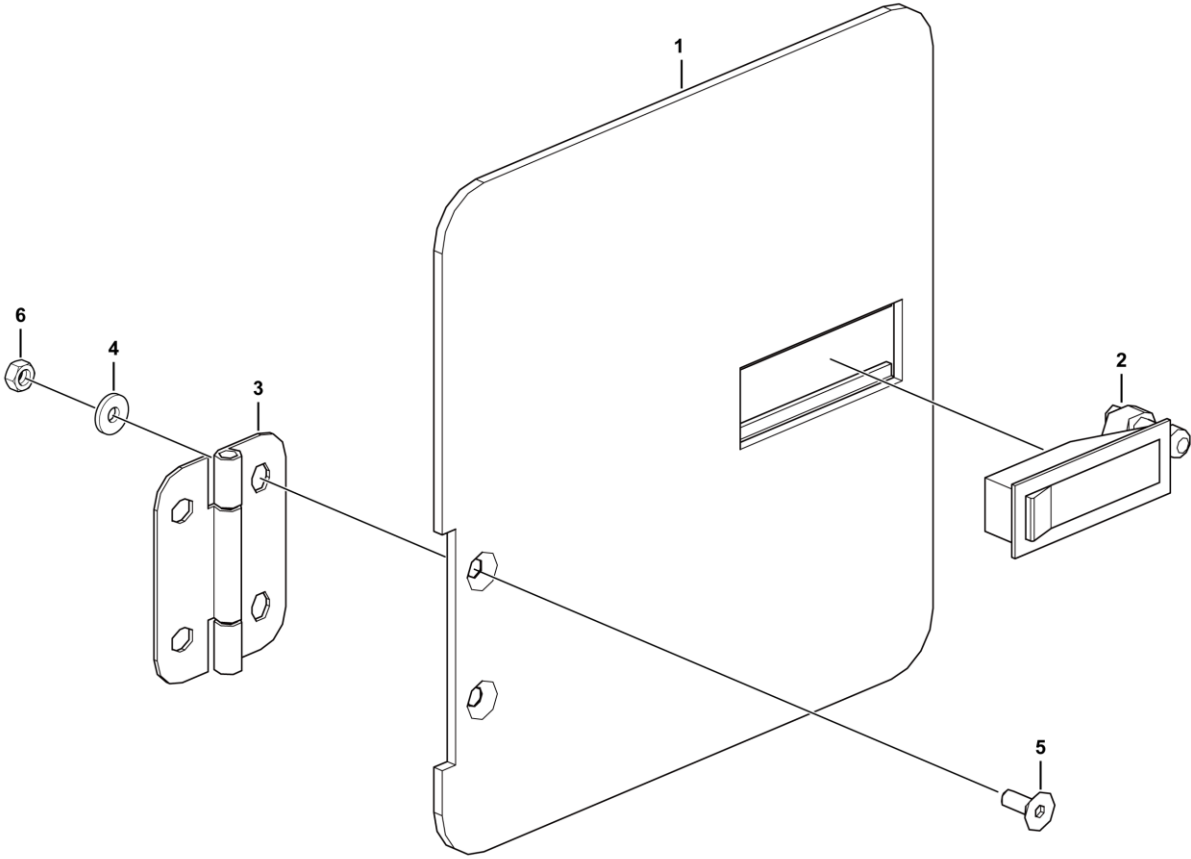

D0702-2516000137.B1b

Left door assembly

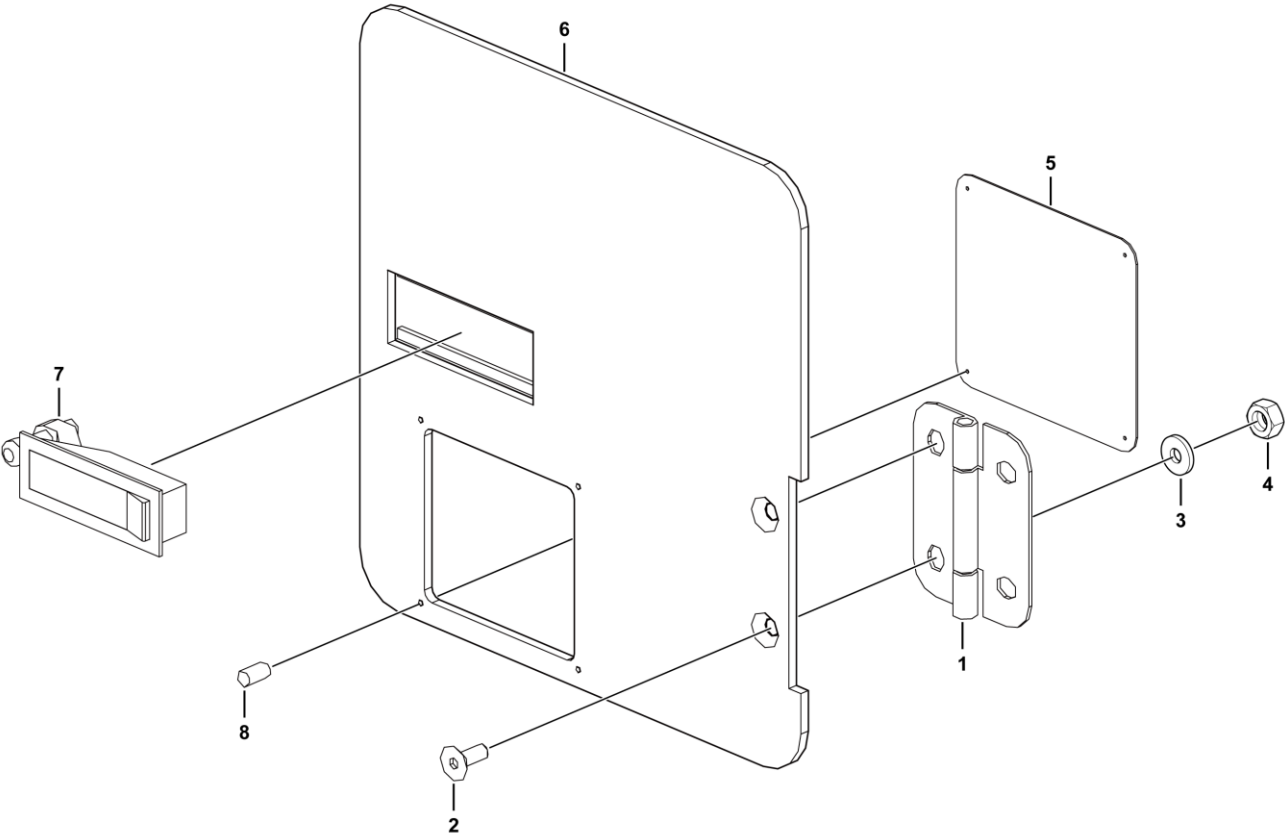

D0701-2516000136.B1b

Pothole protection

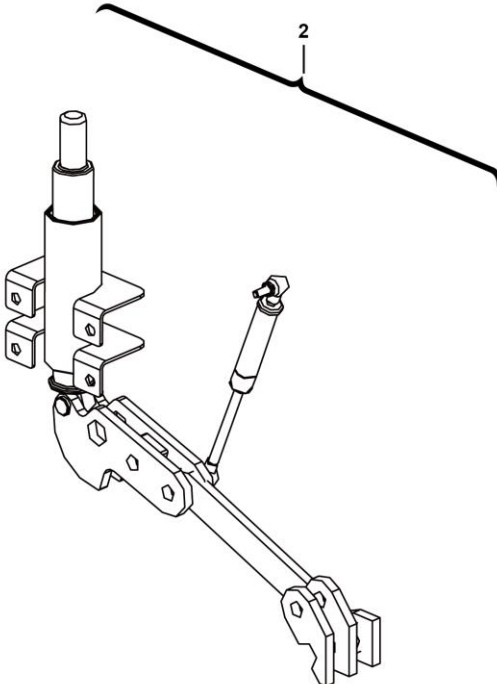
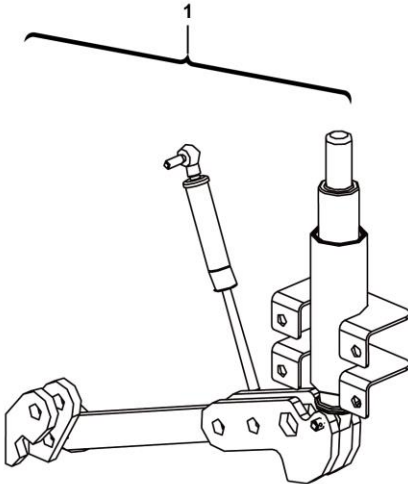

D0900-251900001.B

Right hollow protect

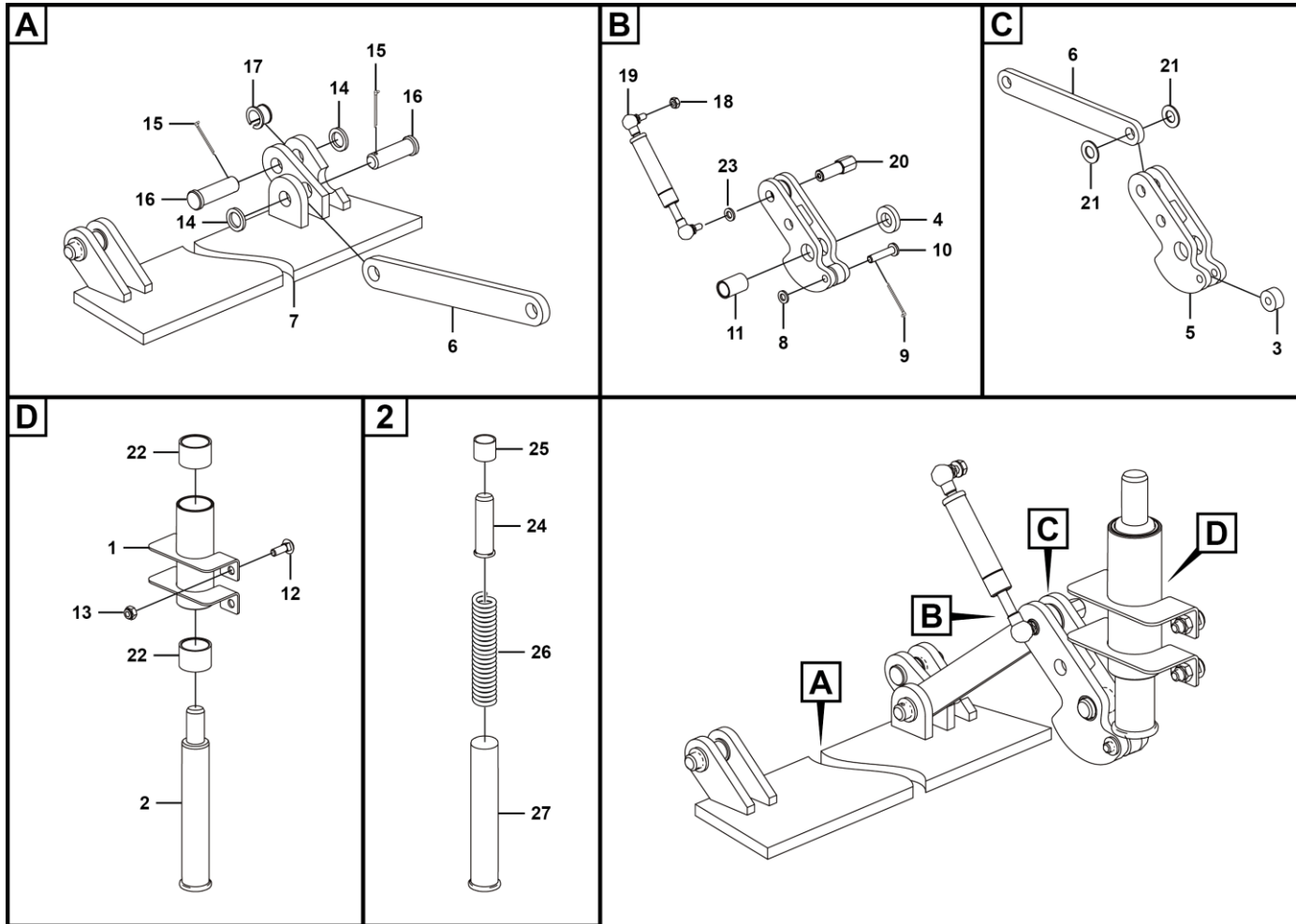

Key	Part No.	Description	Spare parts Y/N	Qty	Remarks
1	25190003401	Fastening assembly	Y	1	
2	25190003161	Pressing shaft assembly	N	1	
3	25190000221	Roller, 28*10*15	Y	1	
4	25190000201	Spacer, 38*20*8	Y	1	
5	25190000101	Weldment, linkage assembly	Y	1	
6	25190000091	Linkage, pithole protection mechanism	Y	1	
7	25190000021	Weldment, right guard plate	Y	1	
8	4015010339	Washer gb97.1-10flznyc-300hv-480	Y	1	
9	4016010138	Cotter pin gb91-3.2*26flznyc-480-q235a	Y	1	
10	25190000231	Pin10, 10*46	Y	1	
11	25190000181	Shaft sleeve20, 25*20*37	Y	1	
12	4011011165	Bolt gb14-m10*35flznyc-8.8-480	Y	4	
13	4013010296	Nut gb889.1-m10flznyc-8	Y	4	
14	4015010342	Washer gb97.1-16flznyc-300hv-480	Y	3	
15	4016010137	Cotter pin gb91-4*28flznyc-480-q235a	Y	3	
16	25190000242	Pin16, 16*54	Y	3	
17	25190000171	Shaft sleeve16, 19*11	Y	2	
18	4013010297	Nut gb889.1-m8flznyc-8-480	Y	1	
19	25190000212	Gas spring,10/22-80-245 (o-o) 400	Y	1	
20	25190000251	Air spring pin, m8*38	Y	1	
21	25190000192	Shim16, 30*16*2	Y	2	
22	25200000141	Shaft sleeve,45*38*32	Y	2	

Right hollow protect

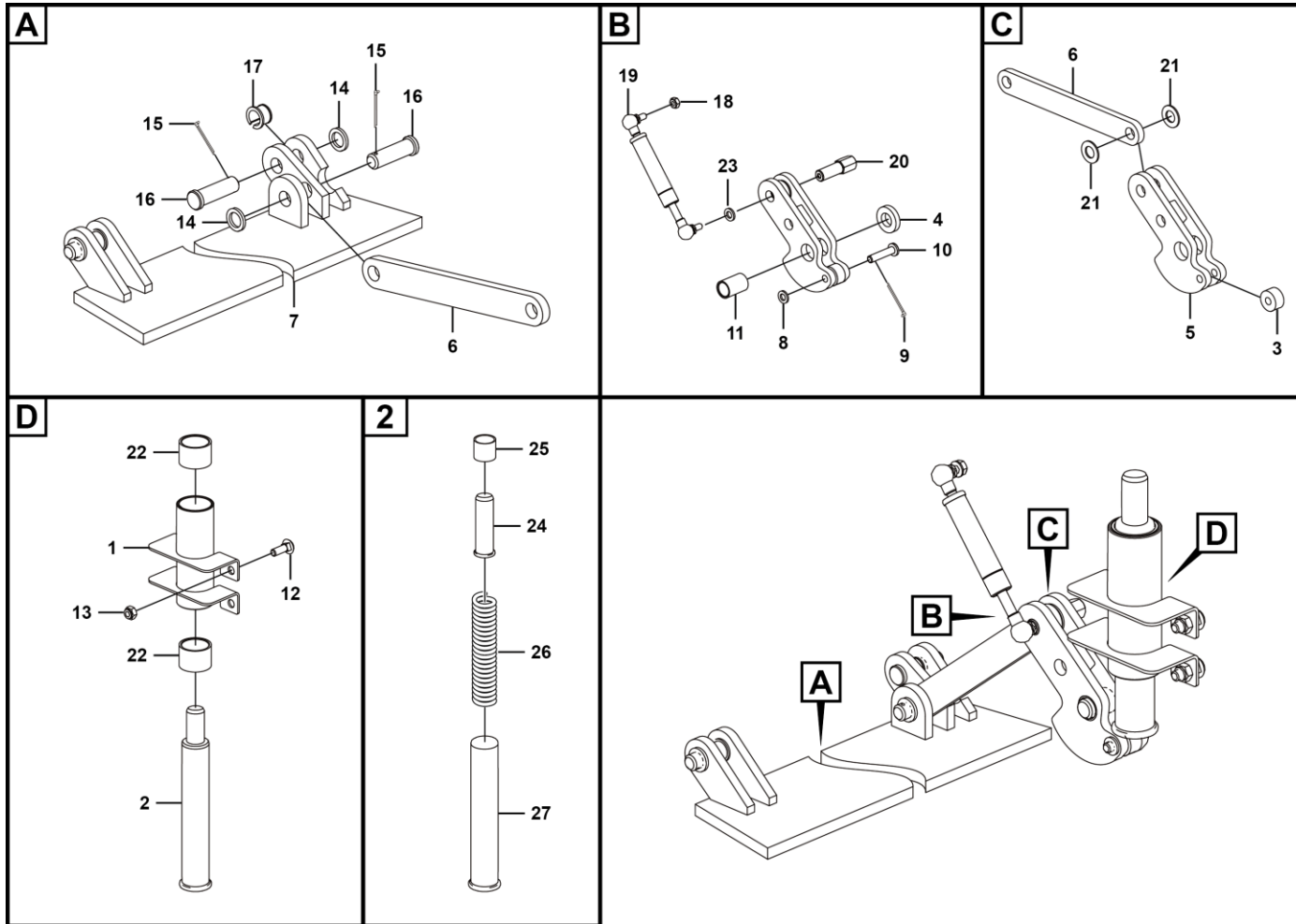

Left hollow protect

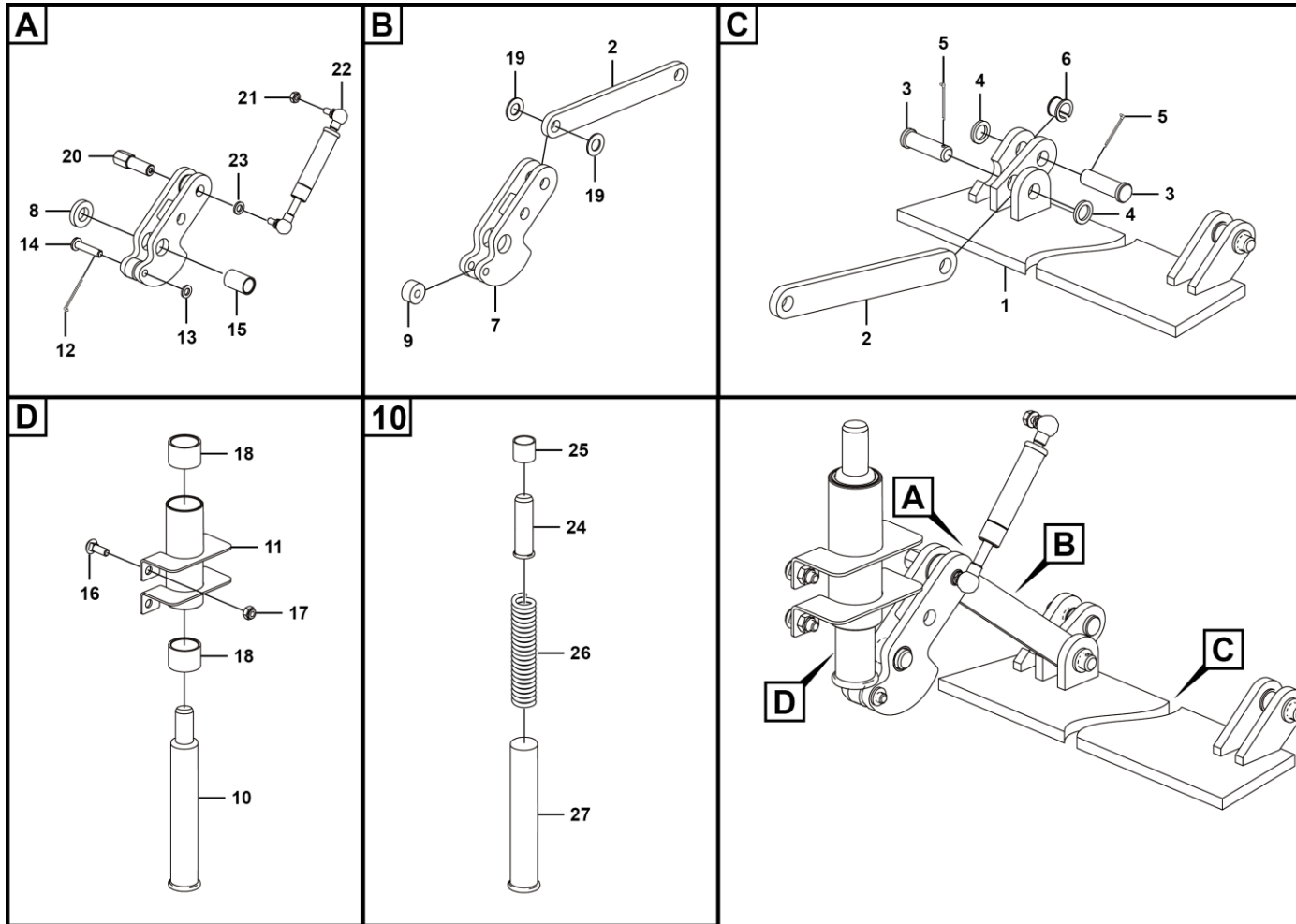

Key	Part No.	Description	Spare parts Y/N	Qty	Remarks
1	25190000031	Weldment, left guard plate	Y	1	
2	25190000091	Linkage, pithole protection mechanism	Y	1	
3	25190000242	Pin16, 16*54	Y	3	
4	4015010342	Washer gb97.1-16flznyc-300hv-480	Y	3	
5	4016010137	Cotter pin gb91-4*28flznyc-480-q235a	Y	3	
6	25190000171	Shaft sleeve16, 19*11	Y	2	
7	25190000101	Weldment, linkage assembly	Y	1	
8	25190000201	Spacer, 38*20*8	Y	1	
9	25190000221	Roller, 28*10*15	Y	1	
10	25190003161	Pressing shaft assembly	N	1	
11	25190003401	Fastening assembly	Y	1	
12	4016010138	Cotter pin gb91-3.2*26flznyc-480-q235a	Y	1	
13	4015010339	Washer gb97.1-10flznyc-300hv-480	Y	1	
14	25190000231	Pin10, 10*46	Y	1	
15	25190000181	Shaft sleeve20, 25*20*37	Y	1	
16	4011011165	Bolt gb14-m10*35flznyc-8.8-480	Y	4	
17	4013010296	Nut gb889.1-m10flznyc-8	Y	4	
18	25200000141	Shaft sleeve,45*38*32	Y	2	
19	25190000192	Shim16, 30*16*2	Y	2	
20	25190000251	Air spring pin, m8*38	Y	1	
21	4013010297	Nut gb889.1-m8flznyc-8-480	Y	1	
22	25190000212	Gas spring,10/22-80-245 (o-o) 400	Y	1	

Left hollow protect

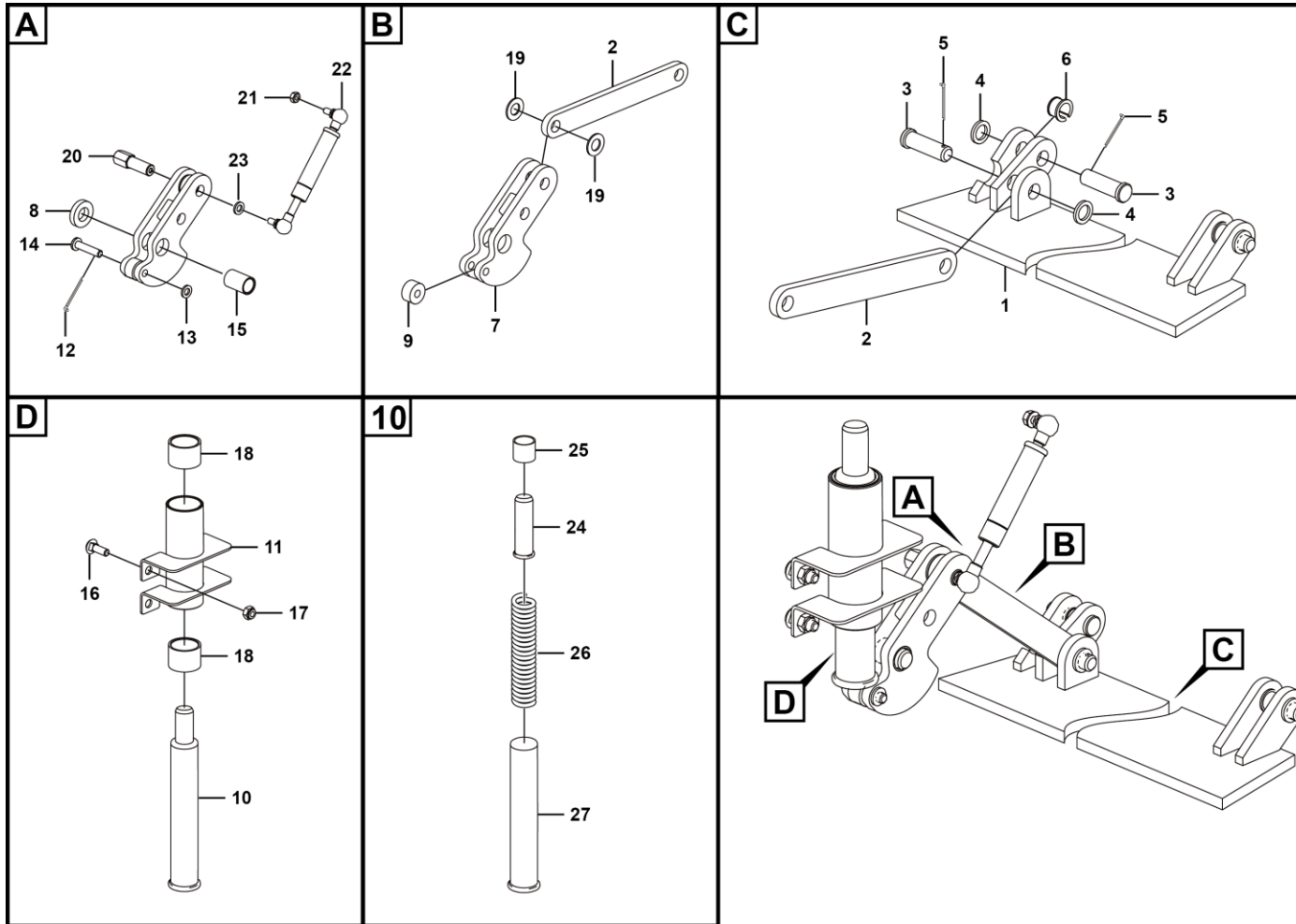

Pressing shaft assembly

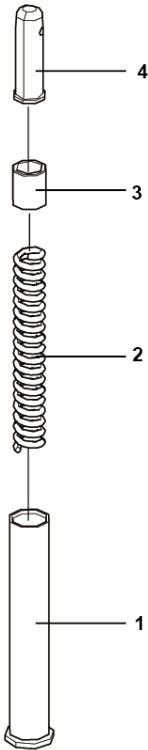

F
STEERING SYSTEM



LINGONG GROUP JINAN HEAVY MACHINERY CO., LTD.

Steering mechanism

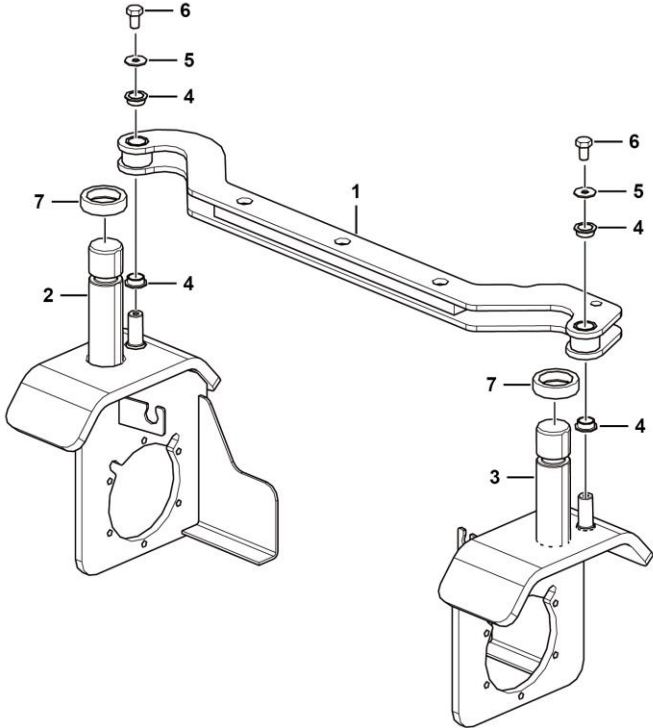

F1200-2517000199.S

G
SCISSOR ASSY INSTALLATION ASSEMBLY



LINGONG GROUP JINAN HEAVY MACHINERY CO., LTD.

Scissor assy installation

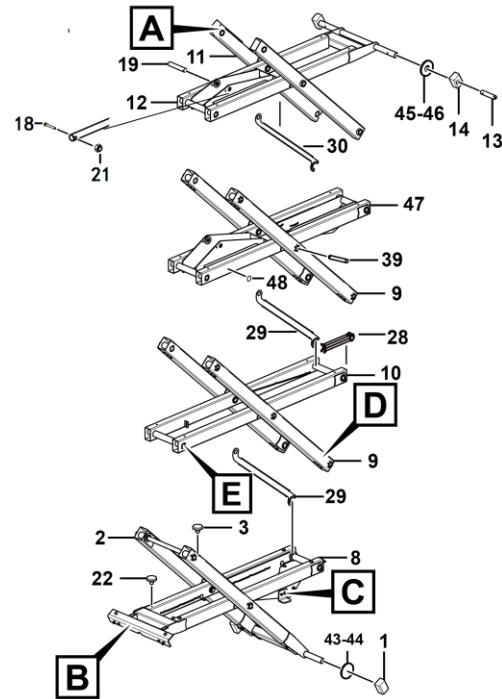
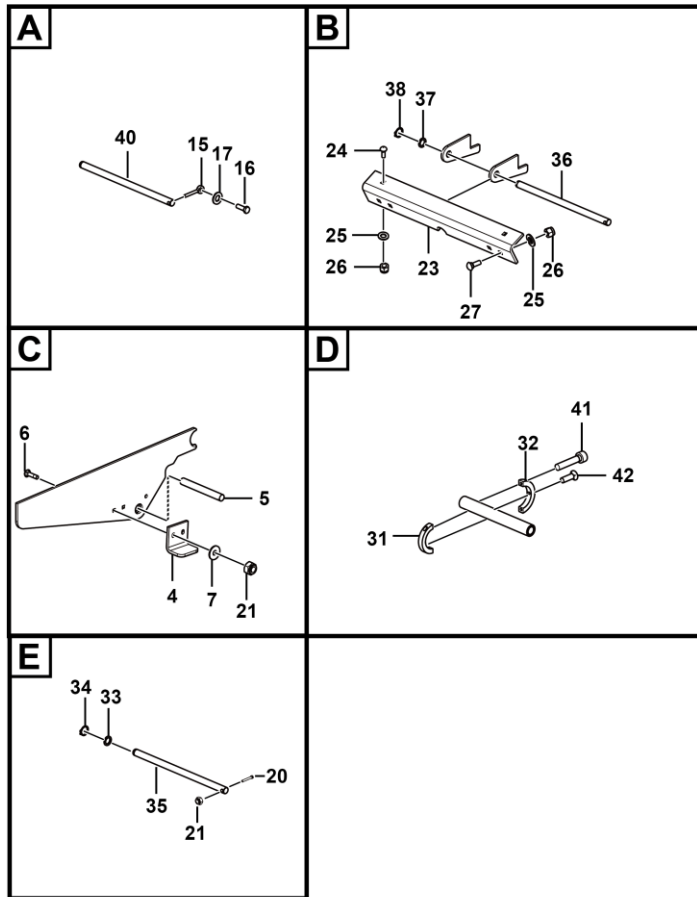

Key	Part No.	Description	Spare parts Y/N	Qty	Remarks
1	25200023041	Slider	Y	2	
2	25200032642	1st outer arm weldment	Y	1	
3	25200009382	Rubber plug, 11.5*11	Y	12	
4	25200000503	Forming (stamping, etc.)	Y	2	
5	4043010149	Pin lzb001 a38*311*11	Y	1	
6	4011011036	Bolt gb14-m10*40flznyc-8.8	Y	4	
7	4015010278	Washer gb96.1-10flznyc-480	Y	4	
8	25200033283	1st inner arm assembly	Y	1	
9	25200032692	Outer arm weldment	Y	4	
10	25200032772	4th inner arm assembly	Y	1	
11	25200032892	5th outer arm assembly	Y	1	
12	25200032942	6th inner arm assembly	Y	1	
13	25200000601	Axle shaft, 38*180	Y	2	
14	25200007141	Slider	Y	2	
15	25200000641	Pin, 10*70	Y	4	
16	4011010707	Bolt gb5783-m10*30flznyc-8.8-480	Y	2	
17	4015010339	Washer gb97.1-10flznyc-300hv-480	Y	6	
18	4011010706	Bolt gb5783-m10*40flznyc-8.8-480	Y	2	
19	4043010148	Pin lzb001 a38*207*11	Y	1	
20	4011010724	Bolt gb5782-m10*75flznyc-8.8	Y	15	
21	4013010296	Nut gb889.1-m10flznyc-8	Y	21	
22	25200000402	Rubber plug,14*11	Y	12	

Scissor assy installation

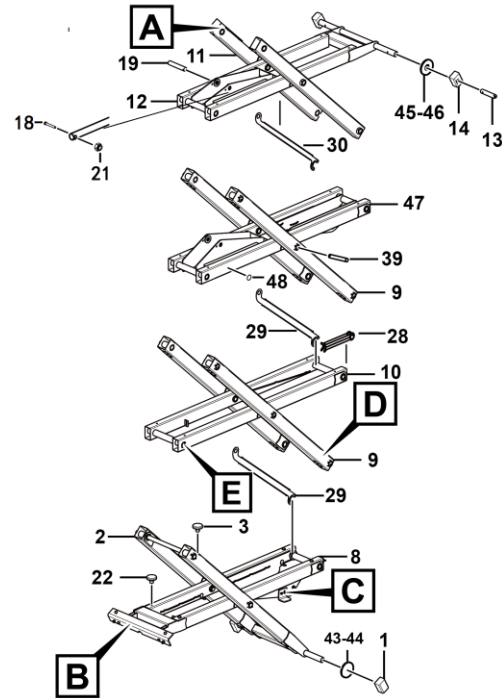
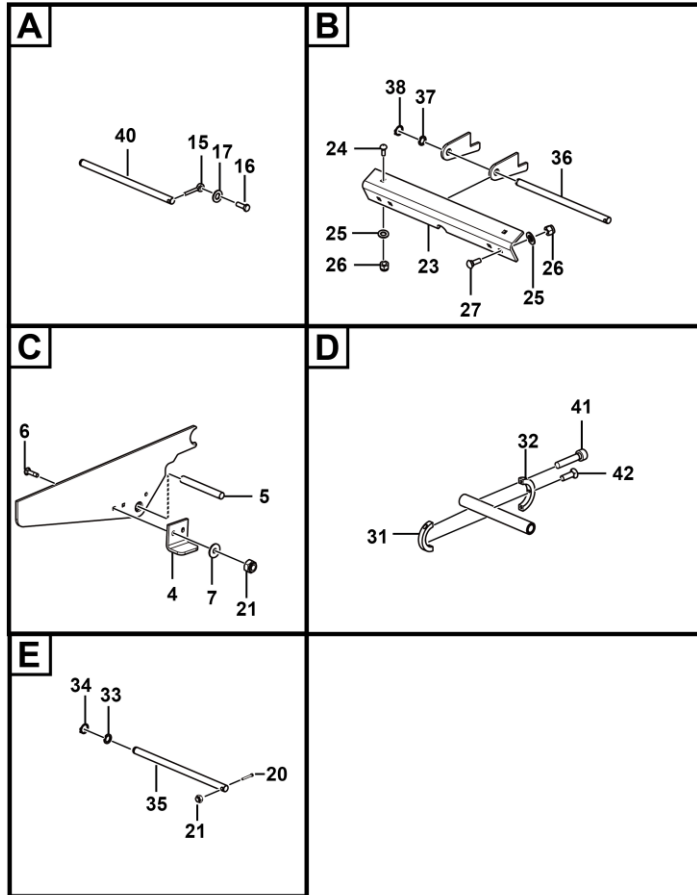

Key	Part No.	Description	Spare parts Y/N	Qty	Remarks
23	25200001062	Fixed plate assembly	Y	1	
24	4011011037	Bolt gb14-m12*35flznyc-8.8	Y	2	
25	4015010286	Washer gb96.1-12flznyc-480	Y	6	
26	4013010301	Nut gb889.1-m12flznyc-8-480	Y	6	
27	4011011010	Bolt gb14-m12*40flznyc-8.8	Y	4	
28	25200000442	Protective arm	N	1	
29	25200001302	Wiring board, fixing harness	Y	1	
30	25200000631	Wiring board, fixing harness	Y	2	
31	25200001531	Retaining ring, fixing inner arm	Y	3	
32	25200001541	Retaining ring, fixing inner arm	Y	3	
33	25200000491	Washer 51*38*3	Y	18	
34	4015010249	Snap ring jb4342-38-65mn	Y	14	
35	4043010221	Pin lzb001 b38*733*11	Y	7	
36	4043010128	Pin lzb001 b25*471*11	Y	1	
37	25200000861	Washer, 51*38*1	Y	1	
38	4015010275	Snap ring jb4342-25-65mn	Y	1	
39	4043010122	Pin lzb001 b38*231*11	Y	6	
40	4043010123	Pin lzb001 b38*746*11	Y	1	
41	4014010112	Screw gb819.1-m6*20flznyc-4.8	Y	3	
42	4014010356	Screw gb70.1-m5*25flznyc-8.8	Y	6	
43	25200009921	Plate, for adjusting the gap between slider and track	Y	2	
44	25200009931	Plate, for adjusting the gap between slider and track	Y	2	

Scissor assy installation

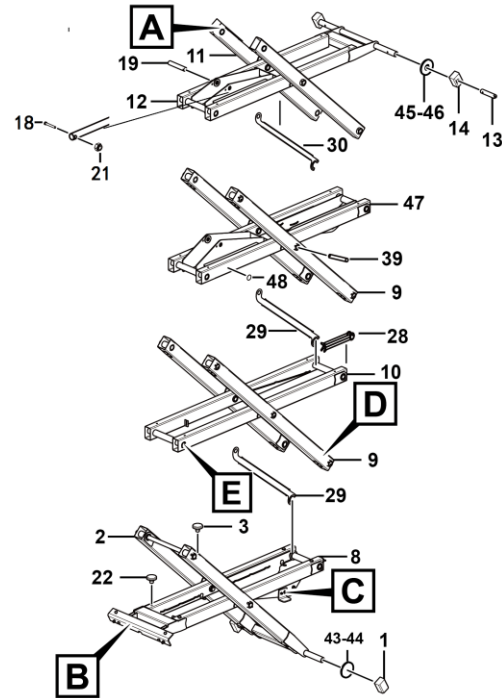
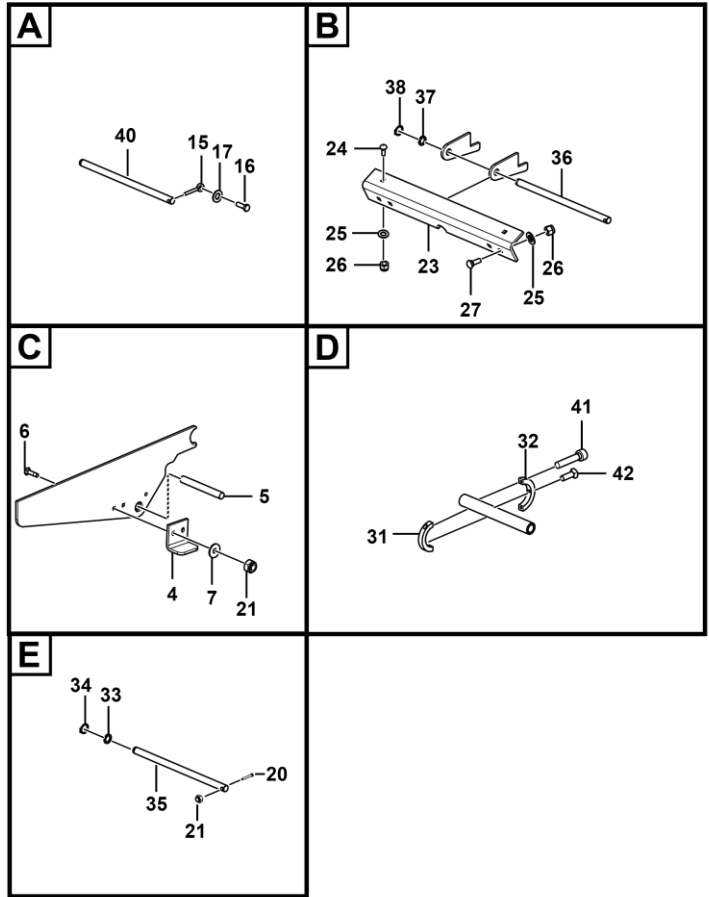

First inner arm assembly

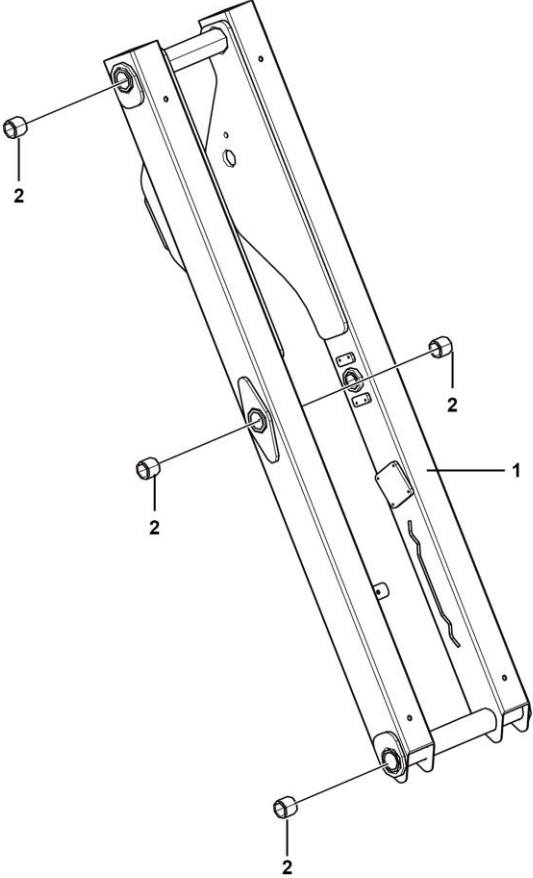

Key	Part No.	Description	Spare parts Y/N	Qty	Remarks
1	25200033273	Frist inner arm assembly	Y	1	
2	25200000141	Shaft sleeve,45*38*32	Y	6	





Inner arm

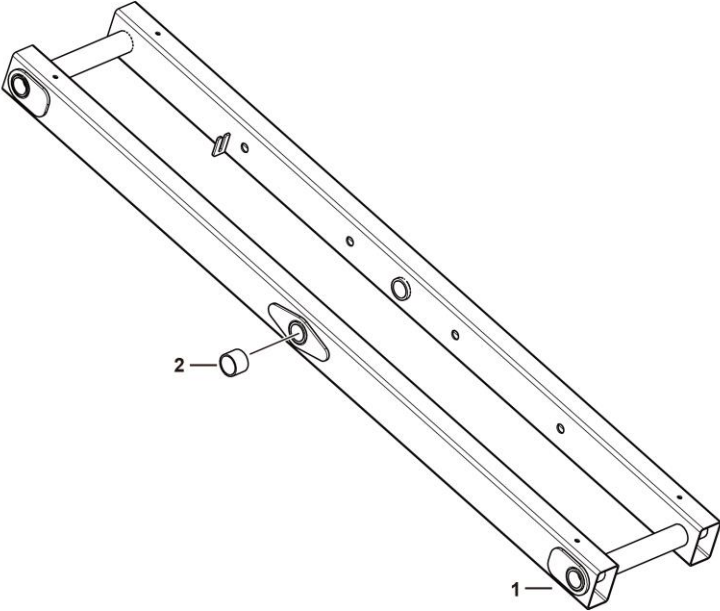

G1300-2520003277.S



Outer arm

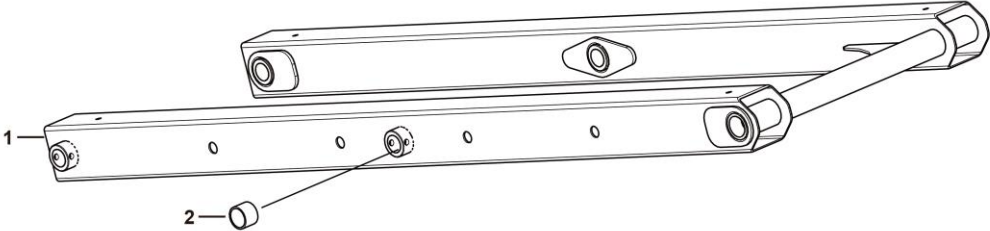

G1300-2520003289.S

Inner arm

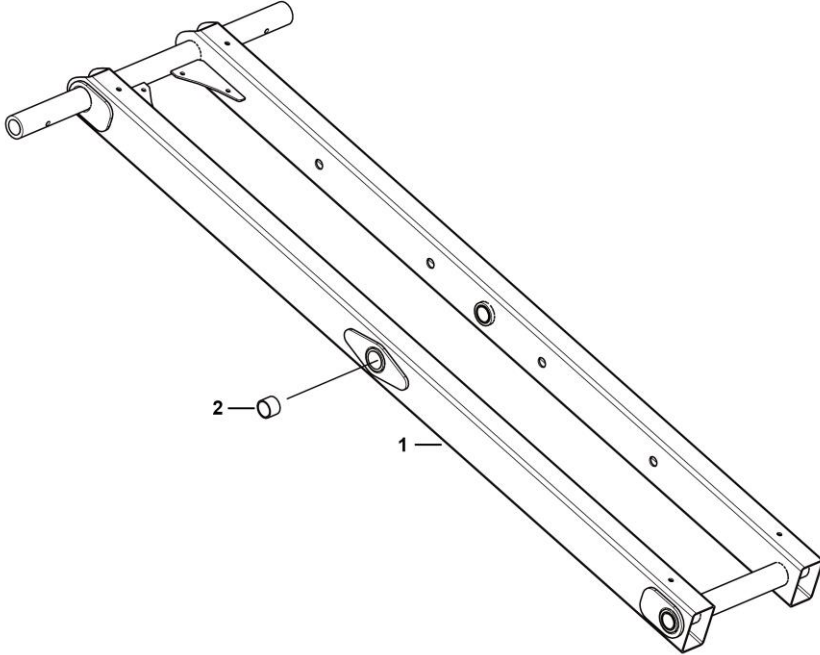

G1300-2520003294.S



Protective arm

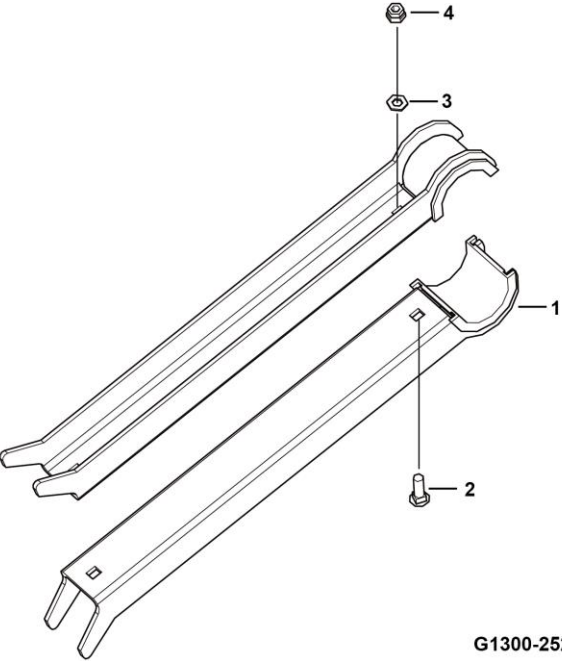

G1300-252000044.B2d

Wiring plate assembly

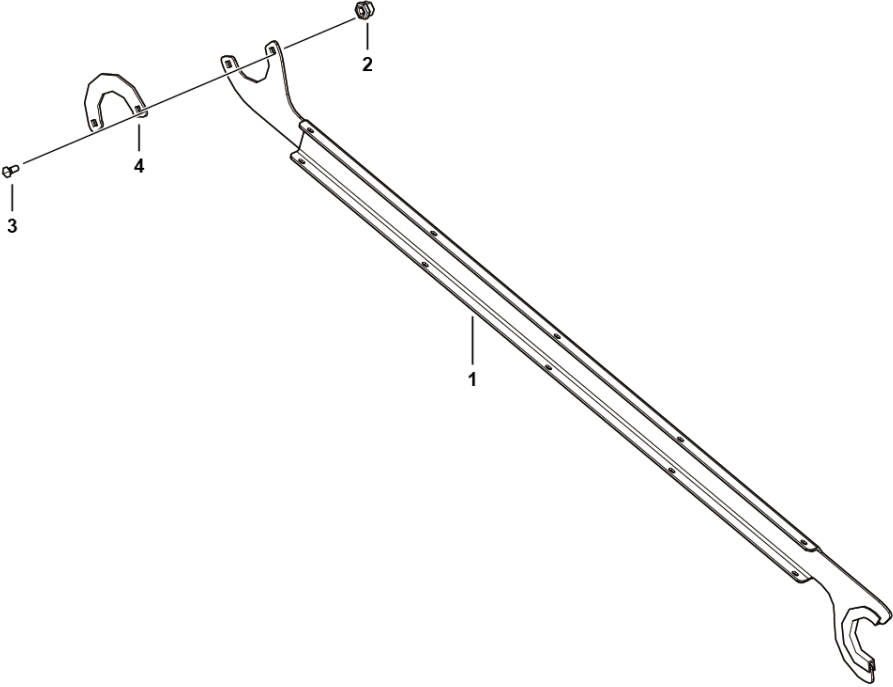

G1300-2520000130.B1a

Key	Part No.	Description	Spare parts Y/N	Qty	Remarks
1	25200001891	Wiring plate,fixing harness	Y	1	
2	4013000211	Nut gb889.1-m6epzn-8	Y	2	
3	4011010447	Bolt gb14-m6*16epzn-8.8	Y	2	
4	25200001291	Curved plate,fixing inner arm	Y	1	



Wiring plate assembly

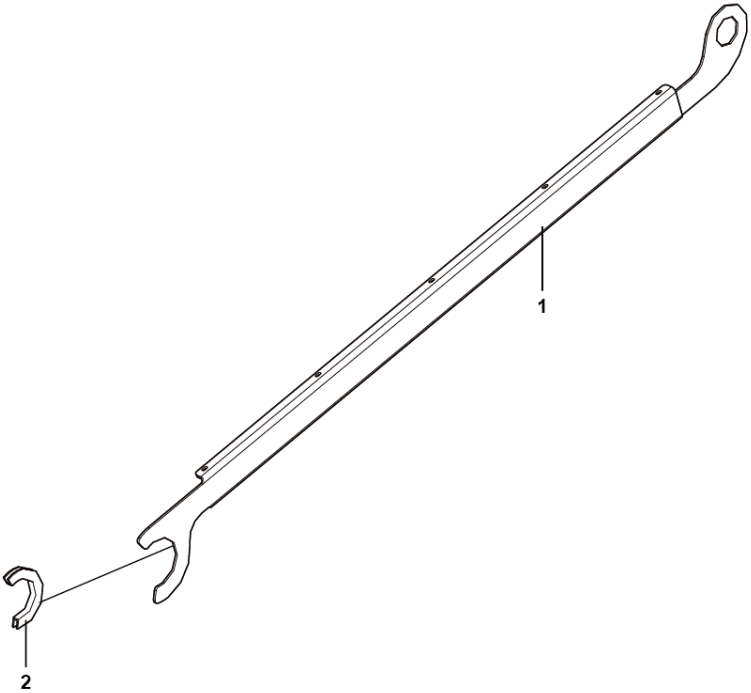

G1300-2520000063.B1b

H SWING SYSTEM



LINGONG GROUP JINAN HEAVY MACHINERY CO., LTD.

Counter weight assembly

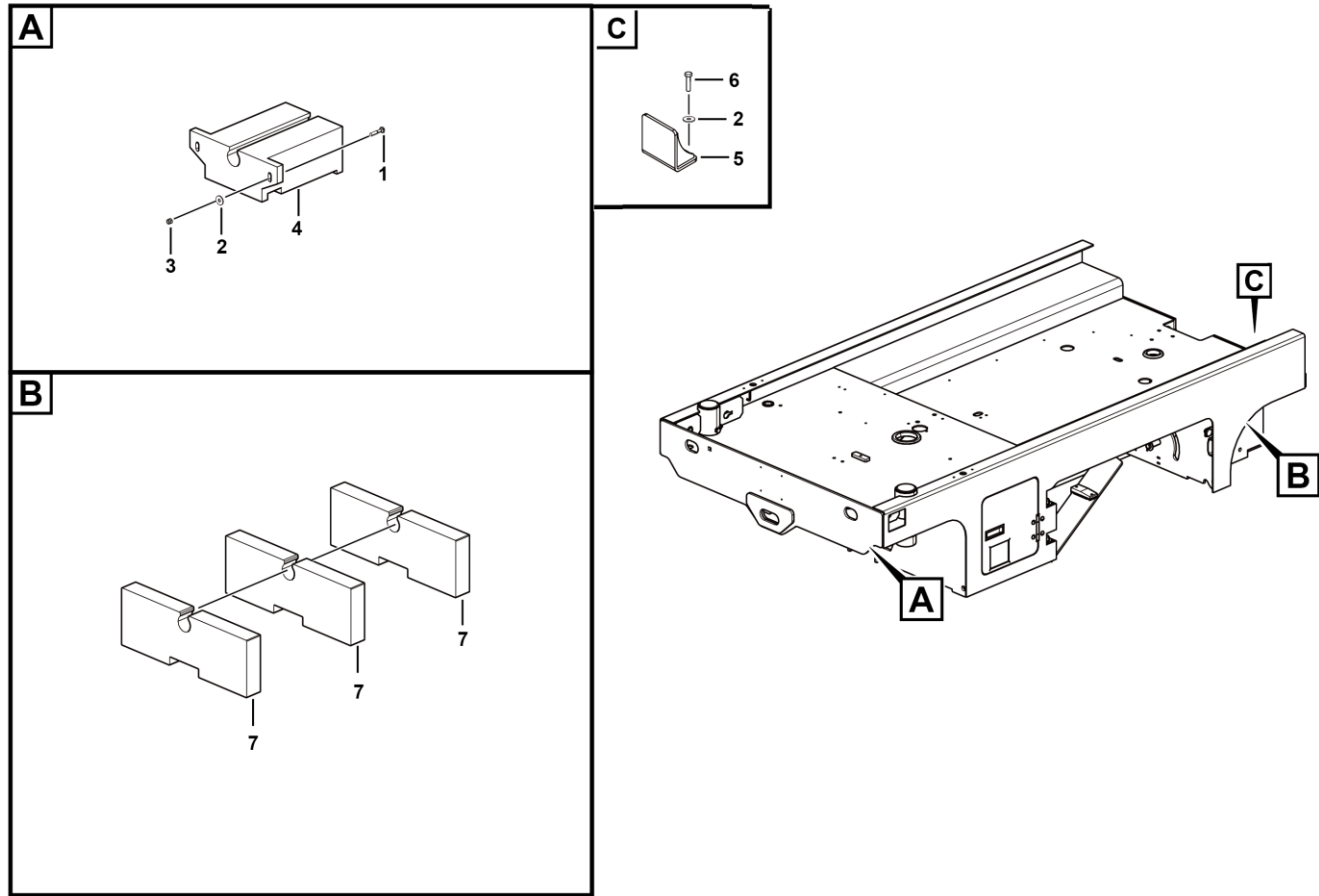

Key	Part No.	Description	Spare parts Y/N	Qty	Remarks
1	4011011476	Bolt gb14-m12*60flznyc-8.8-480	Y	2	
2	4015010286	Washer gb96.1-12flznyc-480	Y	4	
3	4013010301	Nut gb889.1-m12flznyc-8-480	Y	2	
4	25280000062	Front counterweight, 262.43kg	Y	1	
5	25280001662	Weldment,baffle weldment,for fixing counterweight	Y	1	
6	4011010948	Bolt gb5783-m8*45flznyc-10.9-480	Y	2	
7	25280000031	Rear counterweight, 71.65kg	Y	3	



I
COVER ACCESSORY



LINGONG GROUP JINAN HEAVY MACHINERY CO., LTD.

Covering accessory assembly

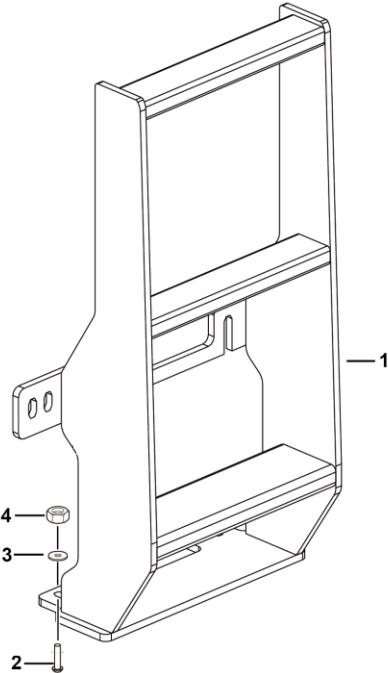

I1700-2529000586.S4c

Key	Part No.	Description	Spare parts Y/N	Qty	Remarks
1	25290005874	Weldment, ladder assembly	Y	1	
2	4011011010	Bolt gb14-m12*40flznyc-8.8	Y	6	
3	4015010286	Washer gb96.1-12flznyc-480	Y	6	
4	4013010301	Nut gb889.1-m12flznyc-8-480	Y	6	



K
PLATFORM ASSEMBLY



LINGONG GROUP JINAN HEAVY MACHINERY CO., LTD.

Platform

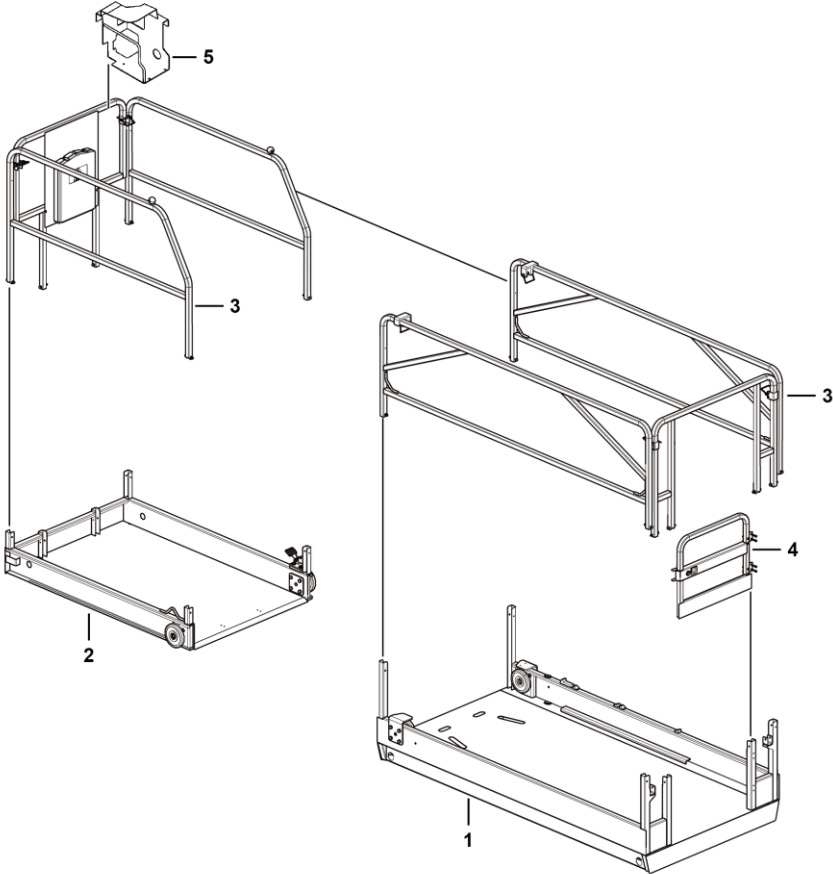

Platform assembly

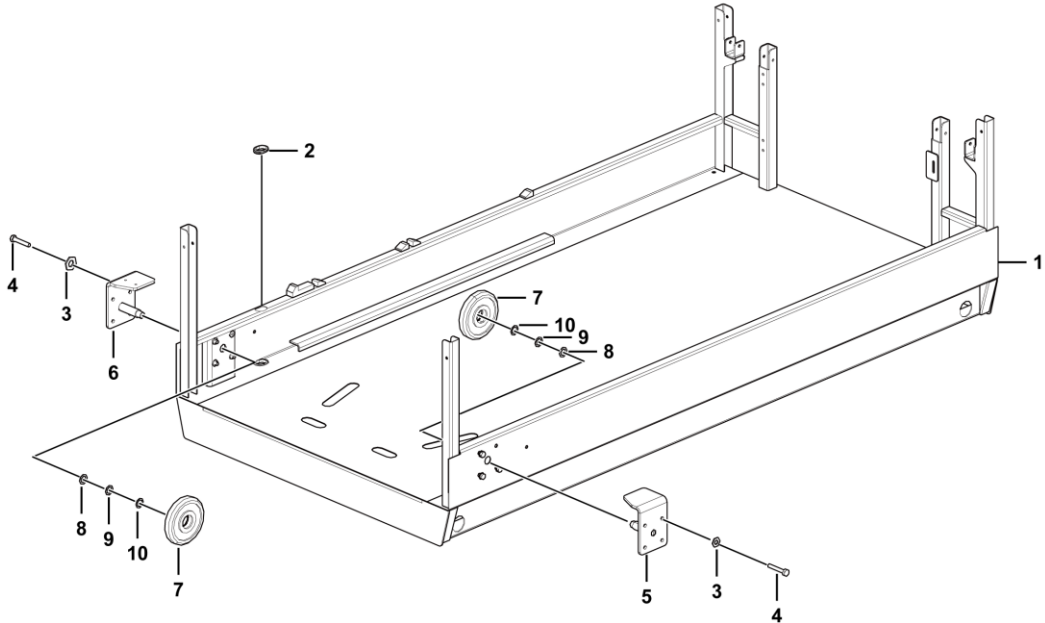

Key	Part No.	Description	Spare parts Y/N	Qty	Remarks
1	25210035545	Weldment,main platform weldment	Y	1	
2	25210042571	Rubber gromet. 31*30*3	Y	3	
3	4015010339	Washer gb97.1-10flznyc-300hv-480	Y	8	
4	4011010732	Bolt gb5782-m10*50flznyc-8.8-480	Y	8	
5	25210030191	Weldment, roller support	Y	1	
6	25210021043	Weldment, roller support	Y	1	
7	25210035932	Roller assembly, φ146	N	2	
8	25210011171	Shim20*2	Y	2	
9	25210011181	Shim20*1	Y	2	
10	25210011191	Shim20*0.5	Y	2	



Extension platform assembly

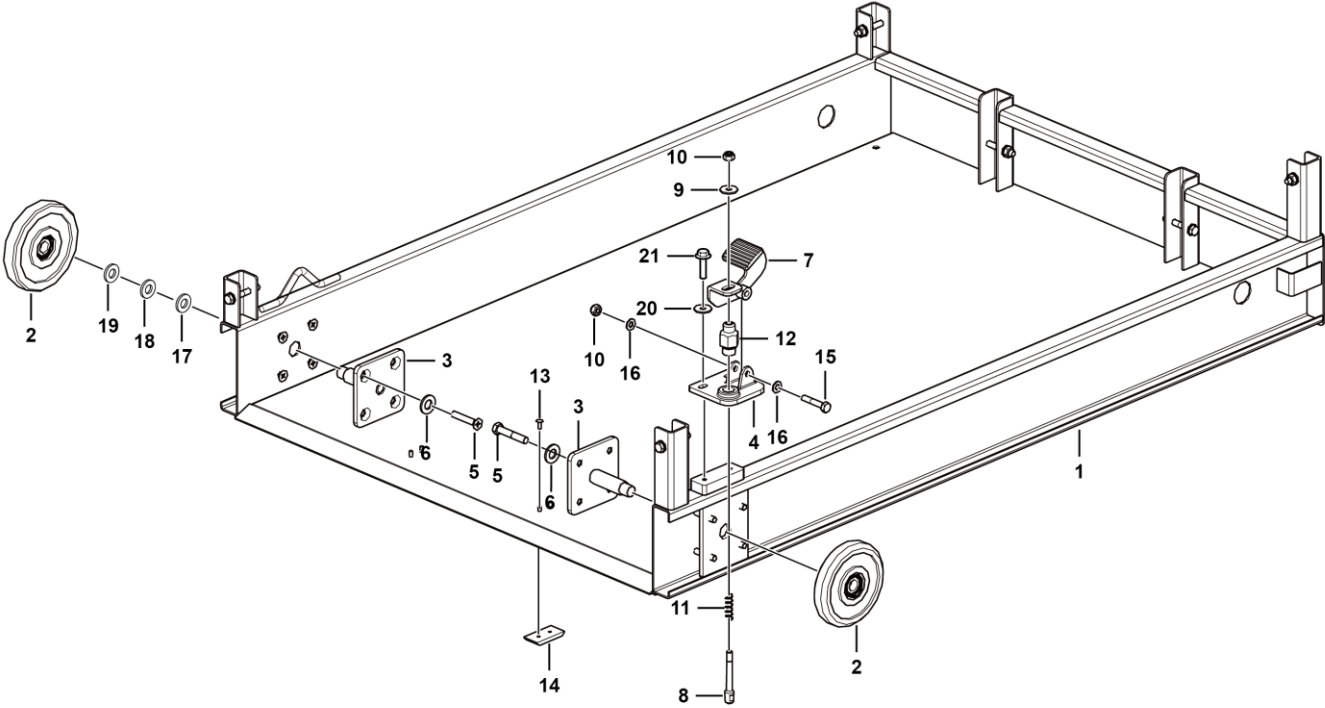

K2100-2521004685.S

Key	Part No.	Description	Spare parts Y/N	Qty	Remarks
1	25210046842	Extended platform deck	Y	1	
2	25210035932	Roller assembly, ϕ 146	N	2	
3	25210030211	Weldment, roller support	Y	2	
4	25210012192	Forming (stamping, etc.), mount, fixing step, extension platform	Y	1	
5	4011010741	Bolt gb5782-m10*55flznyc-8.8-480	Y	8	
6	4015010280	Washer gb97.1-8flznyc-480	Y	8	
7	25210036501	Forming (stamping, etc.), step, extension platform	Y	1	
8	25210002911	Spring pin, m10*73	Y	1	
9	4015010278	Washer gb96.1-10flznyc-480	Y	1	
10	4013010296	Nut gb889.1-m10flznyc-8	Y	2	
11	25210002901	Spring,extension deck	Y	1	
12	25210002891	Spring seat, fixing spring, extension platform	Y	1	
13	4019010177	Rivet gb12618-6*18	Y	4	
14	25210012251	Slider	Y	2	
15	4011011195	Bolt gb5782-m10*50flznyc-10.9-480	Y	1	
16	4015010279	Washer gb97.1-10flznyc-480	Y	2	
17	25210011171	Shim20*2	Y	2	
18	25210011181	Shim20*1	Y	2	
19	25210011191	Shim20*0.5	Y	2	
20	4015010289	Washer gb96.1-8flznyc-480	Y	2	
21	4011011026	Bolt gb5783-m8*20flznyc-10.9-480	Y	2	

Roller assembly

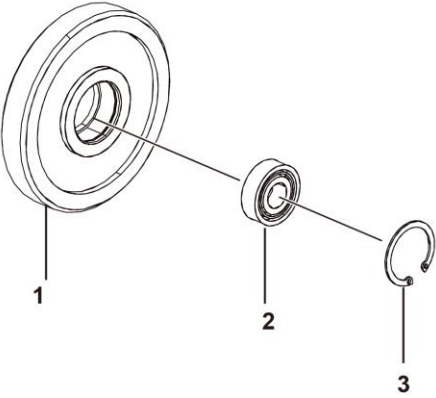

K2100-2521003593.S2a

Rail assembly

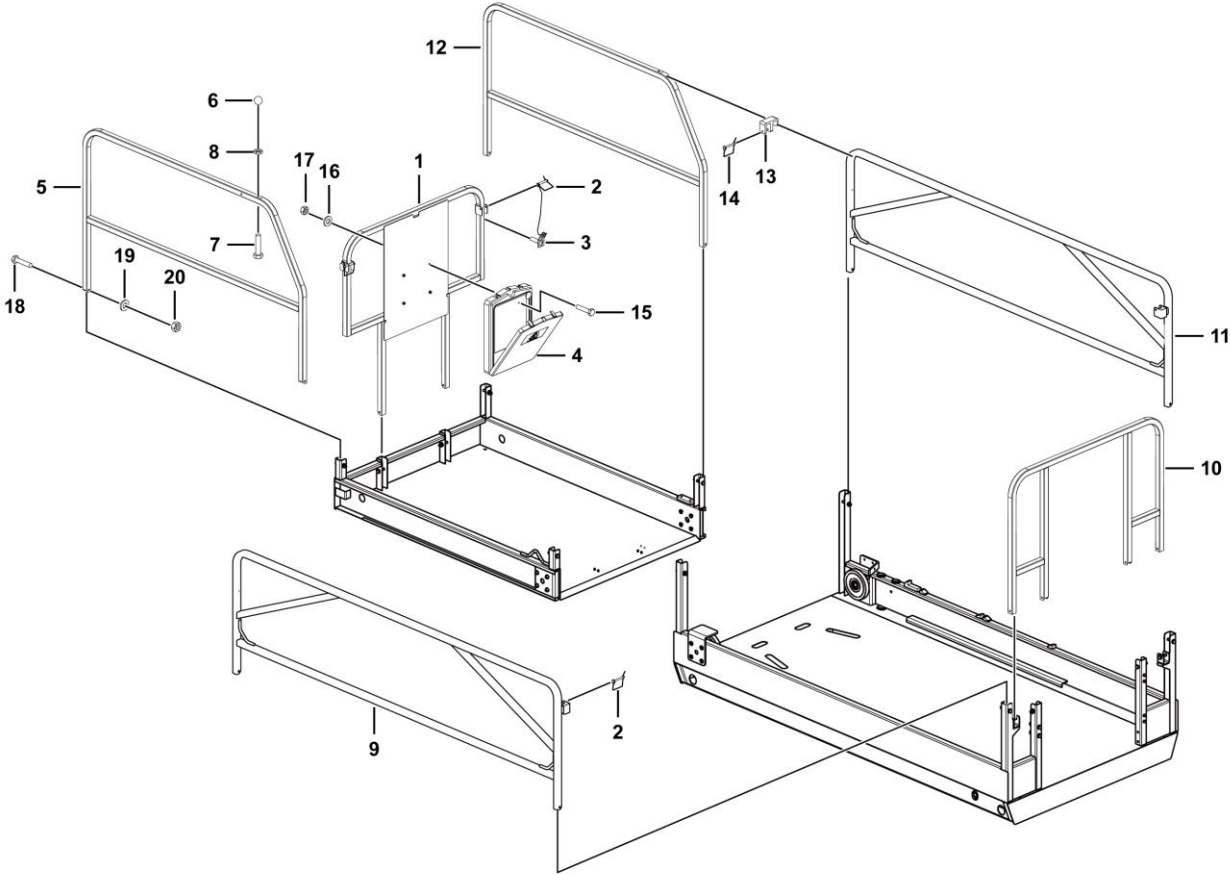

K2100-2521003597.S

Key	Part No.	Description	Spare parts Y/N	Qty	Remarks
1	25210035981	Weldment, front rail weldment,rail	Y	1	
2	4190703890	D-pin 8*65 with 200mm chain and steel sheet	Y	4	
3	4019010209	Break mandrel blind rivet gb12619-5*9	Y	4	
4	25210000821	Manual box	Y	1	
5	25210035951	Weldment, extension deck left rail weldment	Y	1	
6	4190001587	Ball handle 462102	Y	2	
7	4011000489	Bolt gb5783-m10*50epzn-8.8	Y	2	
8	4013000090	Nut gb6172-m10epzn-05	Y	2	
9	25210036102	Weldment, main platform left rail weldment	Y	1	
10	25210036092	Weldment, door rail weldment,rail	Y	1	
11	25210036112	Weldment, main platform right rail weldment	Y	1	
12	25210035961	Weldment, extension deck right rail weldment	Y	1	
13	25210013702	M-mount, fixing door, guardrail	Y	2	
14	4190002586	Pin - square pin with lug 9.5*70	Y	2	
15	4011000154	Bolt gb16674-m6*20epzn-8.8	Y	4	
16	4015000207	Washer gb97.1-6epzn-300hv	Y	4	
17	4013000211	Nut gb889.1-m6epzn-8	Y	4	
18	4011000415	Bolt gb5782-m8*55epzn-8.8	Y	14	
19	4015000072	Washer gb97.1-8epzn-300hv	Y	26	
20	4013000210	Nut gb889.1-m8epzn-8	Y	12	

Semi-swing gate assembly

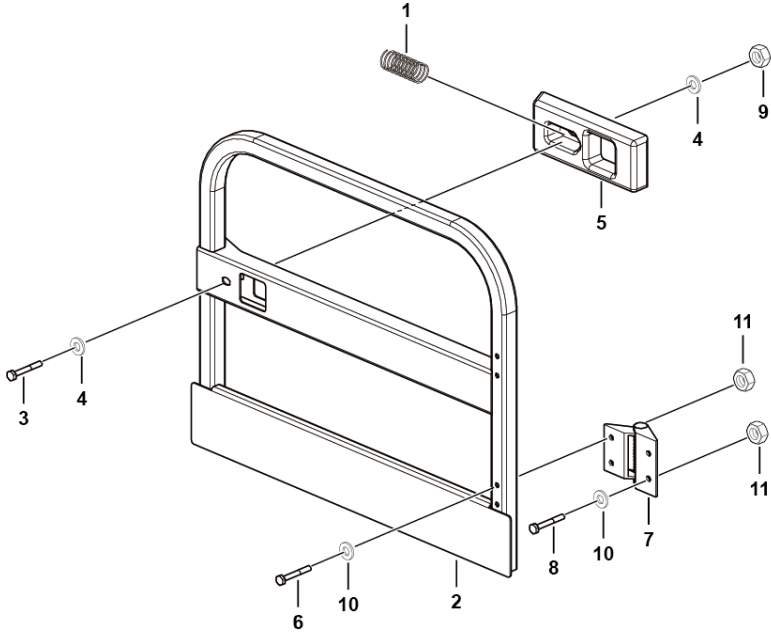

K2100-2521003556.S1a

Key	Part No.	Description	Spare parts Y/N	Qty	Remarks
1	25210002071	Spring 1.4*6*50	Y	1	
2	25210036511	Weldment, swing gate weldment	Y	1	
3	4011000049	Bolt gb5782-m10*55epzn-8.8	Y	1	
4	4015000197	Washer gb96.1-10epzn-300hv	Y	2	
5	25210011051	Plastic block, platform gate	Y	1	
6	4011000611	Bolt gb5782-m6*45epzn-8.8	Y	4	
7	4190001525	Spring hinge x022	Y	2	
8	4011010517	Bolt gb5782-m6*55epzn-8.8	Y	4	
9	4013000189	Nut gb889.1-m10epzn-8	Y	1	
10	4015000207	Washer gb97.1-6epzn-300hv	Y	8	
11	4013000211	Nut gb889.1-m6epzn-8	Y	8	



Bracket

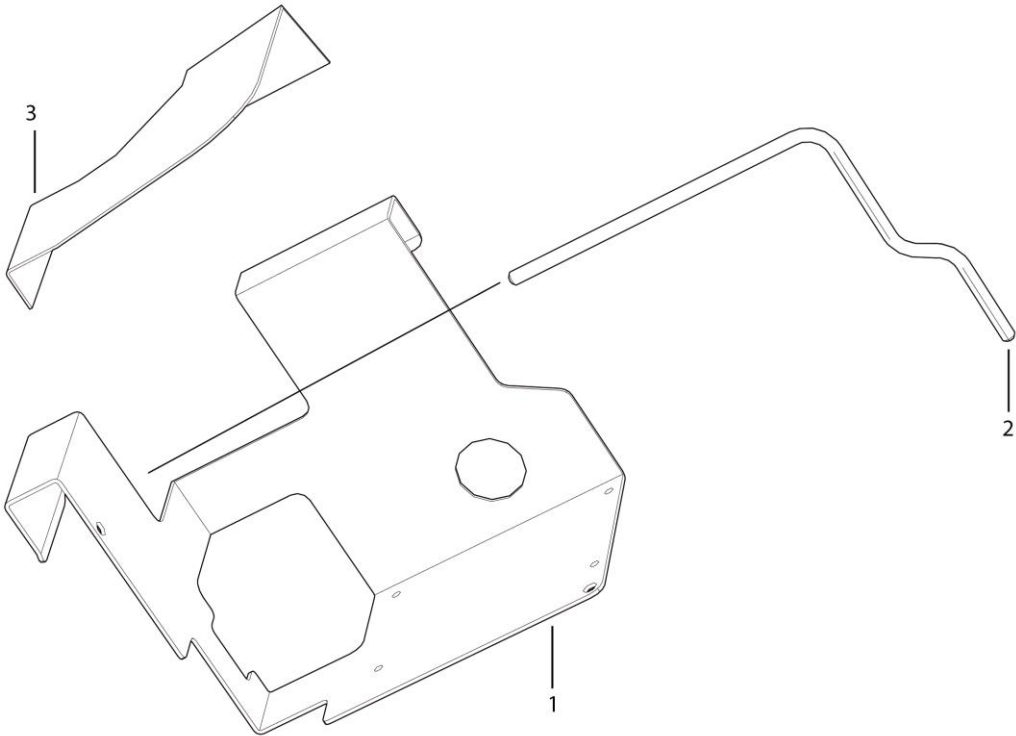

K2106-2521002803

Key	Part No.	Description	Spare parts Y/N	Qty	Remarks
1	25210028041	Plate	N	1	
2	25300000051	Handle	N	1	
3	25210028051	Plate	N	1	



L
HYDRAULIC SYSTEM



LINGONG GROUP JINAN HEAVY MACHINERY CO., LTD.

Travel hydraulic assembly

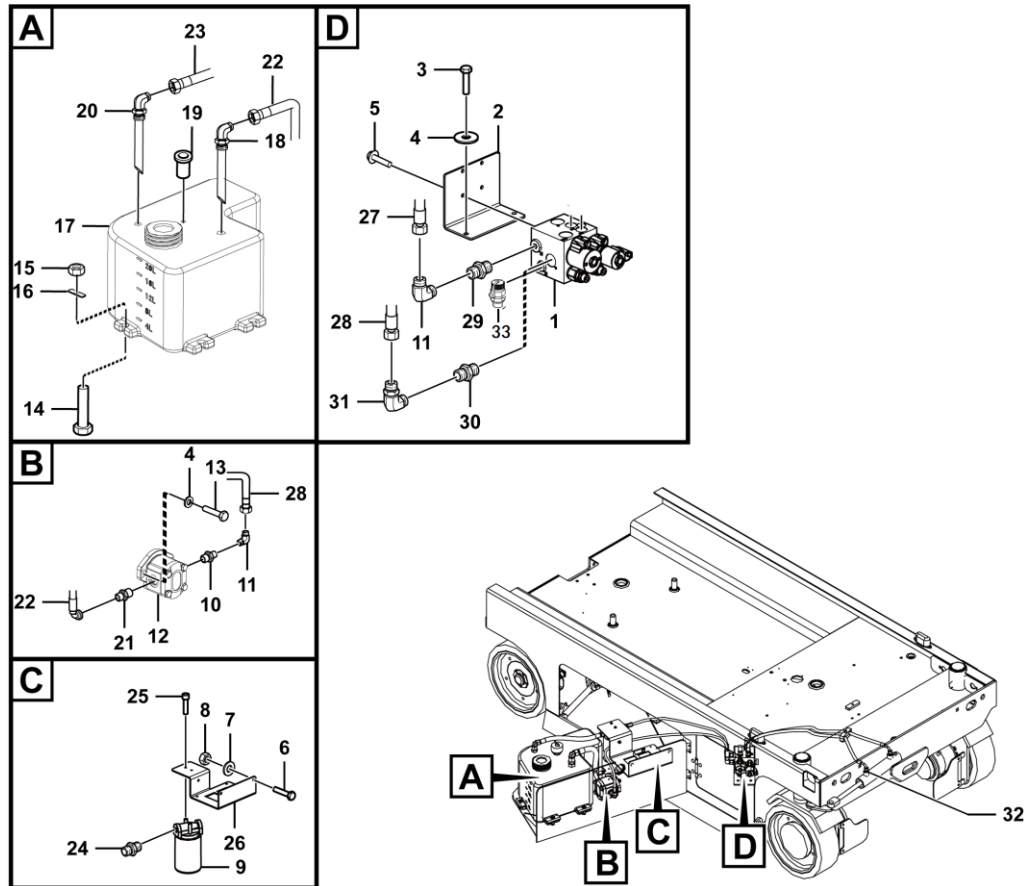

Key	Part No.	Description	Spare parts Y/N	Qty	Remarks
1	4120704774	Main valve st5158-ae00	Y	1	
2	25070000291	Forming (stamping, etc.), fixed plate, for fixing valve	Y	1	
3	4011010707	Bolt gb5783-m10*30flznyc-8.8-480	Y	2	
4	4015010339	Washer gb97.1-10flznyc-300hv-480	Y	4	
5	4011010964	Bolt gb16674-m8*16flznyc-8.8-480	Y	5	
6	4014010338	Screw gb70.3-m6*20flznyc-8.8-480	Y	2	
7	4015010284	Washer gb97.1-6flznyc-480	Y	2	
8	4013010300	Nut gb889.1-m6flznyc-8-480	Y	2	
9	4120001128	Filtersp-06x10	Y	1	
10	4120001500	Fitting 1cb-18-08wd	Y	1	
11	4190000996	Combination fitting 2c9-18	Y	2	
12	4120001488	Gear pump a101098620	Y	1	
13	4011011073	Bolt 3/8-24unf-2b*31flznyc-10.9-480	Y	2	
14	4011011046	Bolt gb5783-m10*45flznyc-8.8-480	Y	4	
15	4013010296	Nut gb889.1-m10flznyc-8	Y	4	
16	25070000251	Forming (stamping, etc.), tank fixed plate	Y	4	
17	4120001123	Tank, 20l, sg-17	Y	1	
18	4120707645	Suction tube assembly, for connecting tank	Y	1	
19	4120001155	Air cleaner sjxkl-m12-h	Y	1	
20	25070000111	Oil return tube assembly, fuel tank-hose	Y	1	
21	4120001497	Fitting 1cb-22-08wd	Y	1	
22	4120002363	Hose j20411-22-10tz/j20491-22-10tz*sr1sn-10*290, tank to gear pump	Y	1	

Travel hydraulic assembly

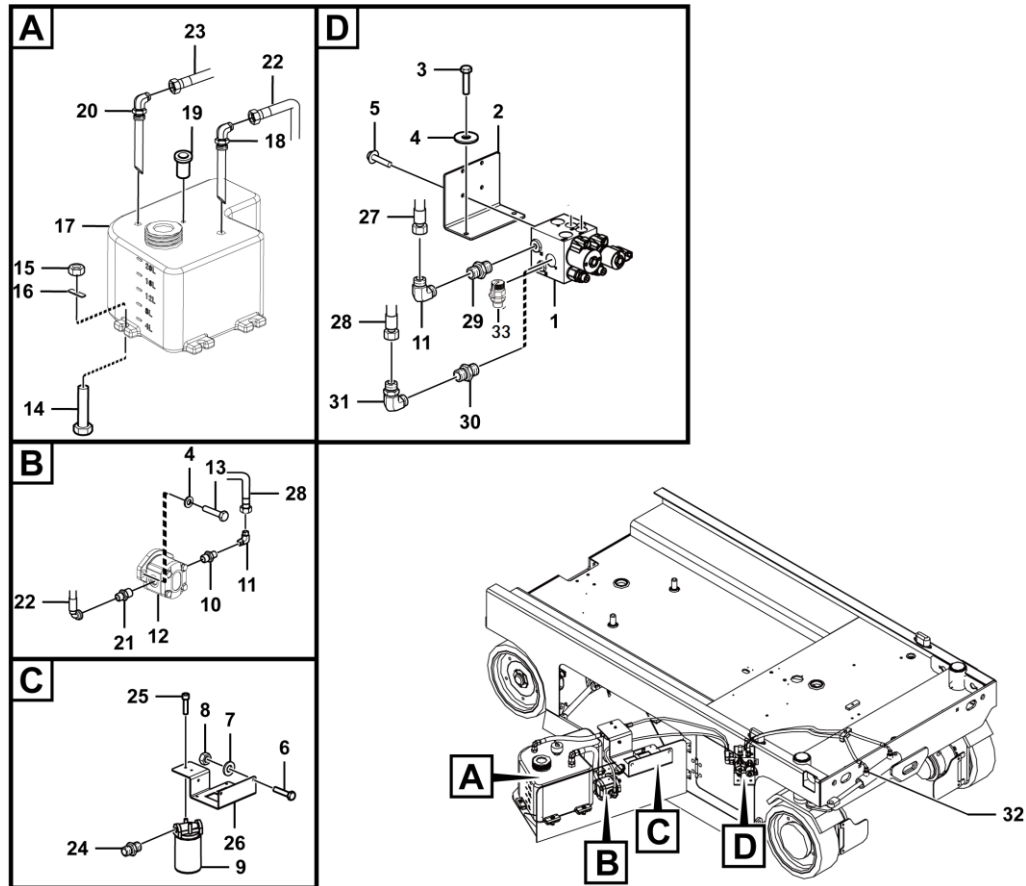

Key	Part No.	Description	Spare parts Y/N	Qty	Remarks
23	4120702868	Hose j20411-18-08tz*sr1sn-08*320, tank-filter	Y	1	
24	25070000091	Straight fitting, $\phi 31 \times 43$	Y	2	
25	4011010735	Bolt gb16674-m6*16flznyc-8.8-480	Y	2	
26	25070000281	Forming (stamping, etc.), mounting plate, for mounting filter	Y	1	
27	4120702952	Hose j20411-18-06tz*sr1sn-06*700+hps700, filter-platform control valve	Y	1	
28	4120702953	Hose j20411-18-06tz/20411-16-06tz*scp3-06*1110+hps1110, gear pump-main valve	Y	1	
29	4120001499	Fitting 1cb-18-06wd	Y	1	
30	4120001799	Fitting, hydraulic 1cb-16-06wd	Y	1	
31	4120001663	Right-angle fitting 2c9-16	Y	1	
32	25070003371	Steering hydraulic assembly	N	1	
33	4120001227	Pressure tap ema3/1/4ed, $\phi 20 \times 49$	Y	1	



Main valve st5158-ae00

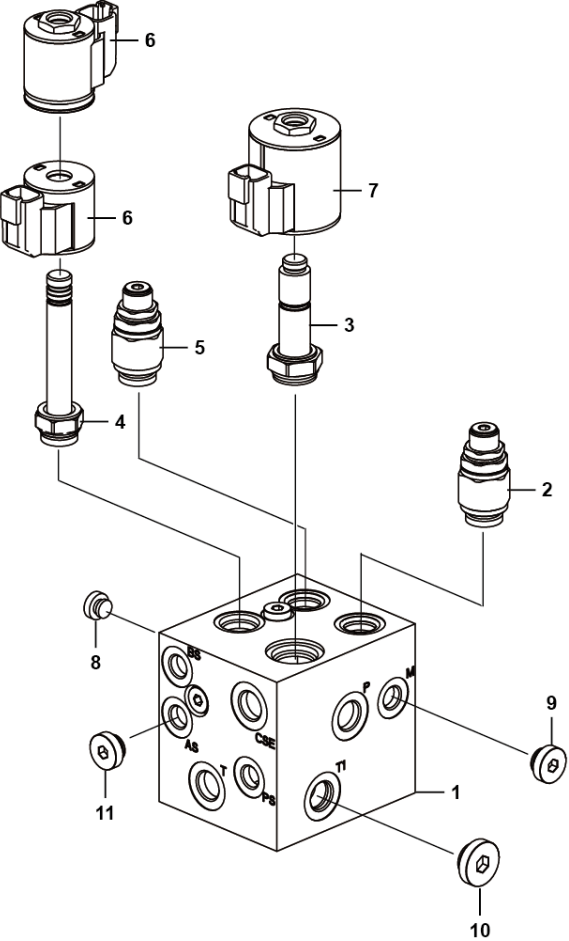

L2300-4120704774

Key	Part No.	Description	Spare parts Y/N	Qty	Remarks
1	4120704774001	Valve block st5158-a00m	Y	1	
2	4120001901002	Relief valve assembly strv08-g-210a, for limiting system pressure	Y	1	
3	4120001159003	Two-position four-way solenoid valve assembly sv10-40-0-n-0, for switching between lifting and steering	Y	1	
4	4120001159005	Three-position four-way solenoid valve assembly sv08-47a-0-n-0, , for switching between left turn and right turn	Y	1	
5	4120001901001	Relief valve strv08-b-120a	Y	1	
6	4120001490011	Coil 4303620	Y	2	
7	4120001490012	Coil 4303720	N	1	
8	4129900116002	Plug 4bn-02wd	Y	10	
9	4190001419	Plug 4bn-04wd	Y	2	
10	4120001493	Plug 4bn-06wd	Y	1	
11	4120001159006	M6 damper stty002-1.0	Y	2	



Filter

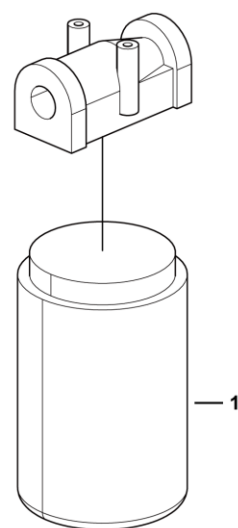

L2300-4120001128

Gear pump a101098620

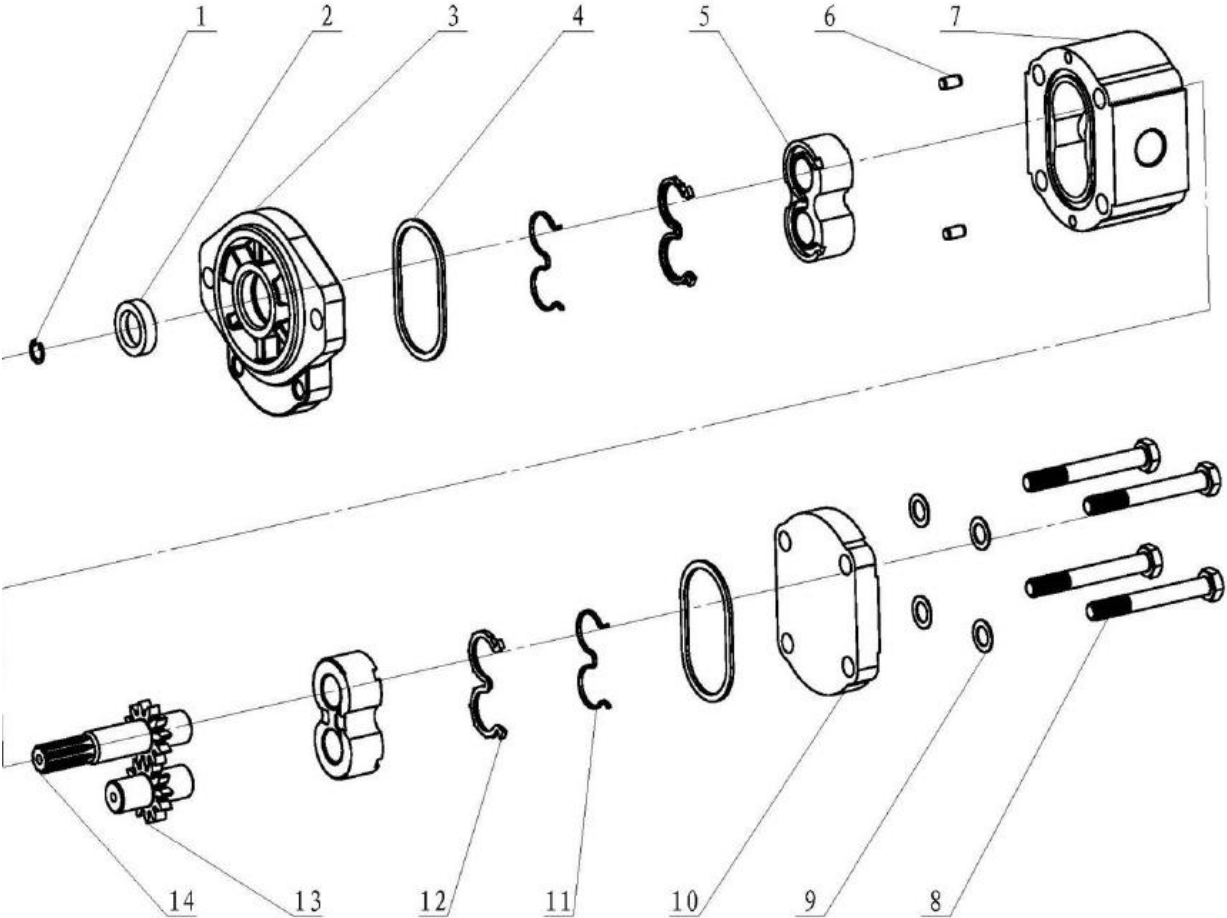

Key	Part No.	Description	Spare parts Y/N	Qty	Remarks
1	4120001431005	Snap ring for hole p03700013	Y	1	
2	4120001431002	Oil seal p01200050	Y	1	
3	4120001431006	Front cover a012010236	Y	1	
4	4120001431003	Outer sealring p01010072	Y	2	
5	4120001431007	Shaft sleeve assembly a012460054	Y	2	
6	4120001431008	Dowel pin p03420002	Y	2	
7	4120001488001	Unit pump a012107630	Y	1	
8	4120001488002	Hexagon head bolt p03100114	Y	4	
9	4120001488003	Saddle rebound washer p03610032	N	4	
10	4120001488004	Rear cover a012020121	Y	1	
11	4120001431004	E-type snap ring p01100025	Y	2	
12	4120001431013	E-ring p01020077	Y	2	
13	4120001488005	Driven gear a012300223	Y	1	
14	4120001488006	Driving gear a012203638	Y	1	

Steering hydraulic assembly

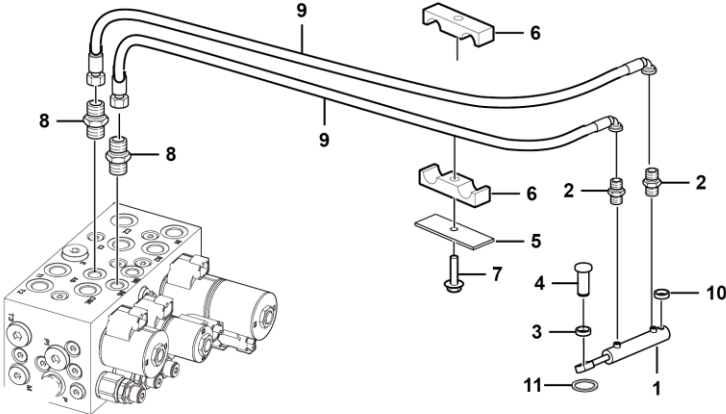

L2302-2507000337.S1a

Key	Part No.	Description	Spare parts Y/N	Qty	Remarks
1	4120703457	Steer cylinder 40*20*152.4-400	Y	1	
2	4120001340	Fitting 1co-14-04	Y	2	
3	25070002524	Shaft sleeve φ30	Y	2	
4	25070002542	Steer cylinder pin 20*59	Y	1	
5	25080000151	Pipe clamp2, for fixing hose	Y	1	
6	25060000391	Pipe clamp 4, for fixing steer cylinder hose	Y	2	
7	4011000481	Bolt gb16674-m8*30epzn-8.8	Y	1	
8	4120001368	Fitting, hydraulic 1cb-14-04wd	Y	2	
9	4120703209	Hose j20411-14-04tz/j20491-14-04tz*sr16sc-04*900, main valve-steer cylinder	Y	2	
10	25070002531	Shaft sleeve 1, 27*9	Y	2	
11	4015010246	Snpring gb894.1-19-65mn	Y	2	



Lifting hydraulic assembly

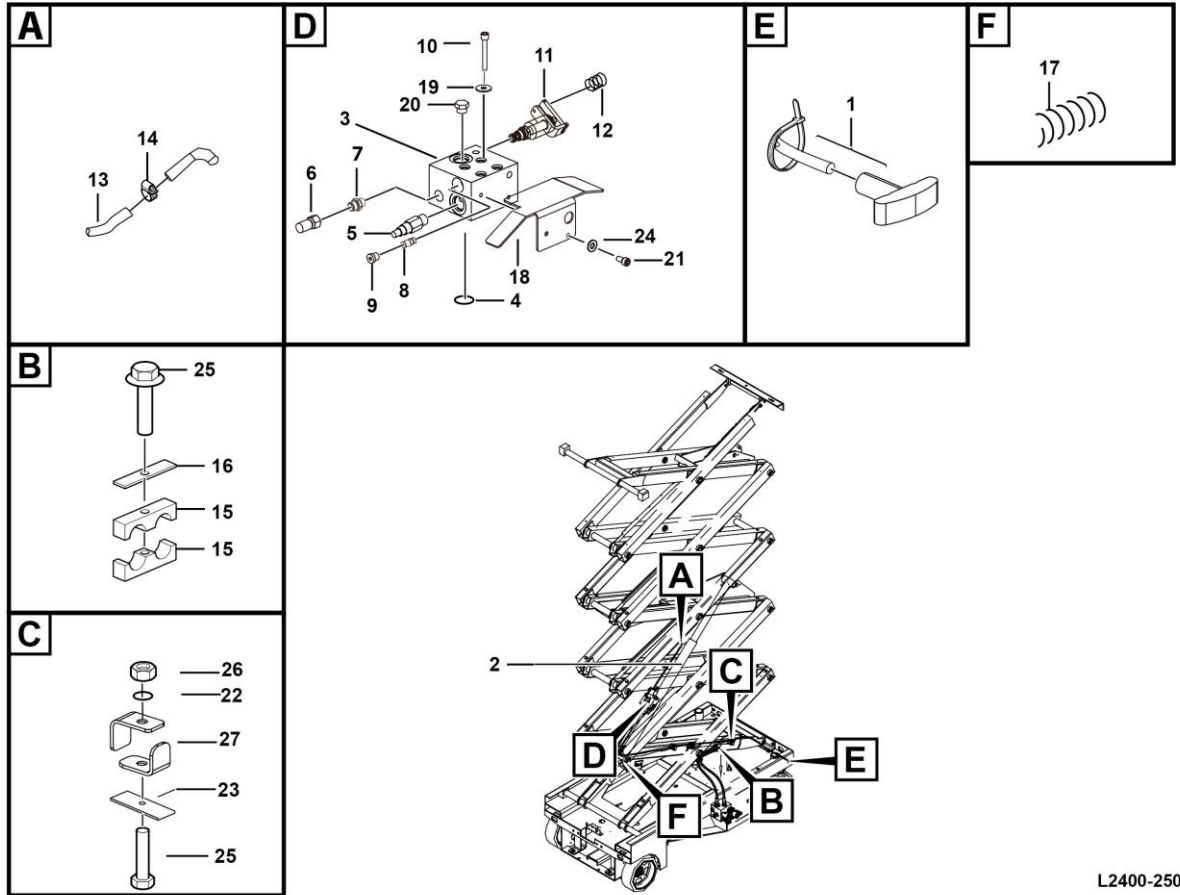

L2400-2508000217.S1h

Key	Part No.	Description	Spare parts Y/N	Qty	Remarks
1	25080001572	Cable assembly, brake	Y	1	
2	4120703496	Lifting cylinder	Y	1	
3	25080002232	Cylinder valve block	Y	1	
4	4120002399	O-ring 10.77*2.62	Y	1	
5	4120001156	Safety valve rv08-20a-0-n-33/m187, preventing excessive pressure	Y	1	
6	4120702951	Hose assembly	Y	1	
7	4120001499	Fitting 1cb-18-06wd	Y	3	
8	4120001234	Hole	Y	1	
9	4120002398	Plug 4mn-14wd	Y	1	
10	4014010232	Bolt gb5782-m8*70flznyc-12.9-480	Y	4	
11	4120002350	Proportional directional valve	Y	1	
12	25080001331	Spring 1.5*15*30	Y	1	
13	4120705190	Hose fc402ca1206-4750	Y	1	
14	4017000010	Hose clamp jb8870-d20	Y	1	
15	25080000143	Pipe clamp2, for fixing hose	Y	2	
16	25080000151	Pipe clamp2, for fixing hose	Y	1	
17	4120001532	Hose sheath pg-062(300)	Y	2	
18	25080003681	weldment , valve block guard plate assembly	Y	1	
19	25080002881	M8 hard gasket,16*8.5*3	Y	4	
20	4120001130	Check valve cv08-20-0-n-10, preventing oil from flowing back	Y	2	
21	4014000120	Screw gb70.1-m6*12epzn-8.8	Y	2	
22	4015000072	Washer gb97.1-8epzn-300hv	Y	1	

Lifting hydraulic assembly

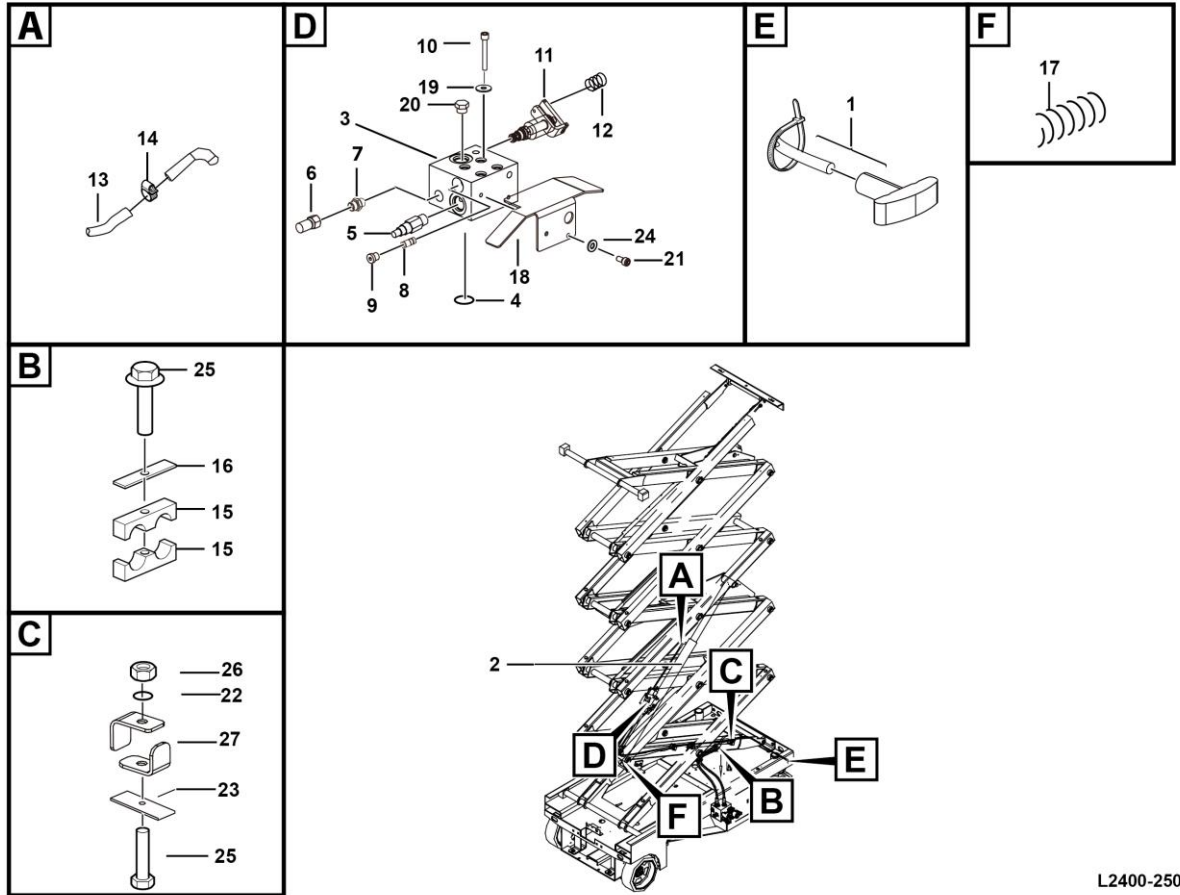

L2400-2508000217.S1h

Cable assembly

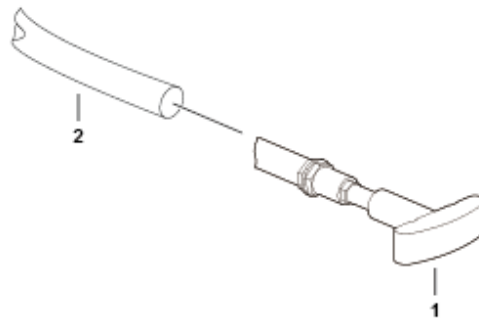

L2400-2508000207.S2a

Lifting cylinder

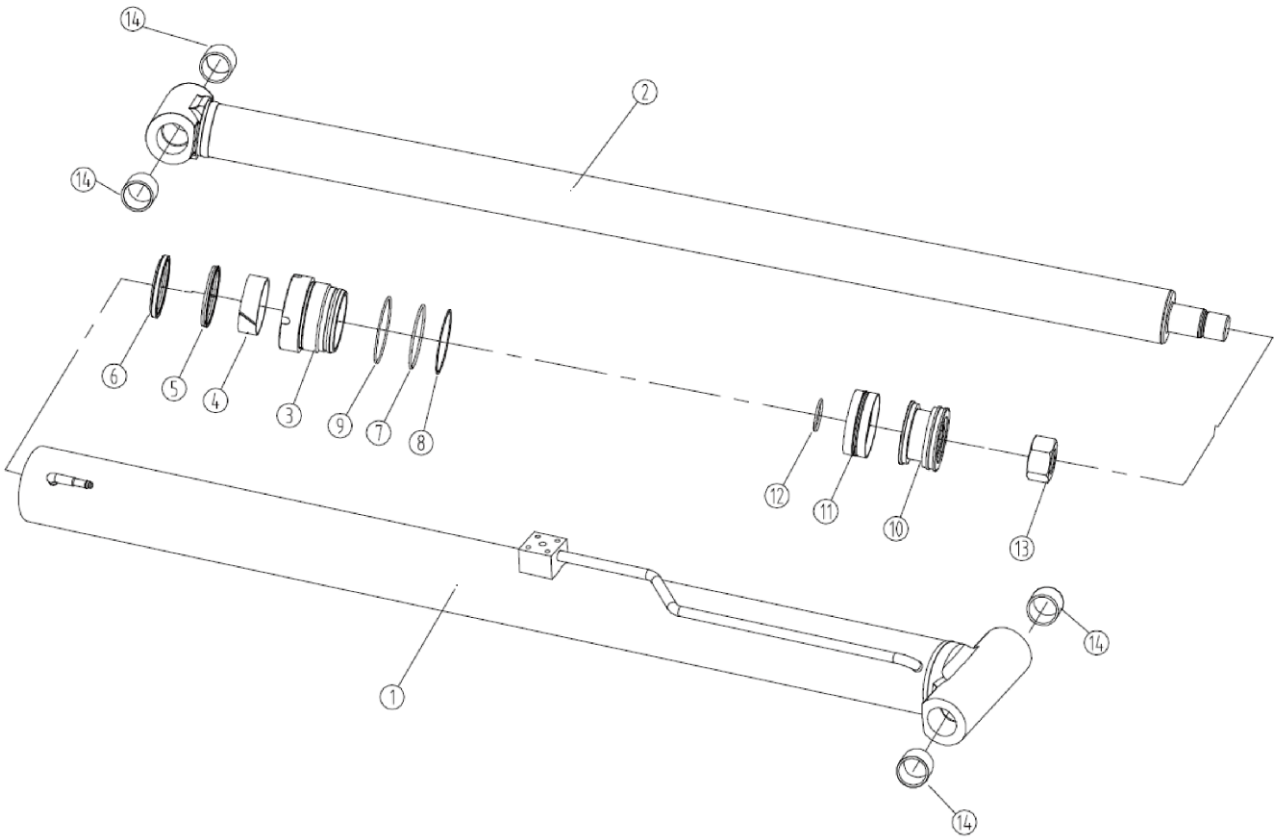

L2400-4120703496

Key	Part No.	Description	Spare parts Y/N	Qty	Remarks
1	4120703496001	Cylinder body24a331240	Y	1	
2	4120703496002	Piston body24a310120	Y	1	
3	4120703496003	Cover24a370070	Y	1	
4	4120703496004	Supporting-ring24g30754c	Y	1	
5	4120703503008	Seal-piston rod 24f207503	N	1	
6	4120703503010	Seal-dustproof 24d507502	N	1	
7	4120703503011	O-ring 24k10850a	N	1	
8	4120703503012	Snap-o	N	1	
9	4120703503013	O-ring 24k309001	N	1	
10	4120703496005	Piston24a380140	Y	1	
11	4120703503014	Sealing-piston	N	1	
12	4120703497010	O-ring 24k104006	N	1	
13	4120703496006	Nut401800106	Y	1	
14	4120703496007	Sleeve24c046030	Y	4	

M
ELECTRIC SYSTEM



LINGONG GROUP JINAN HEAVY MACHINERY CO., LTD.

Electricity assembly

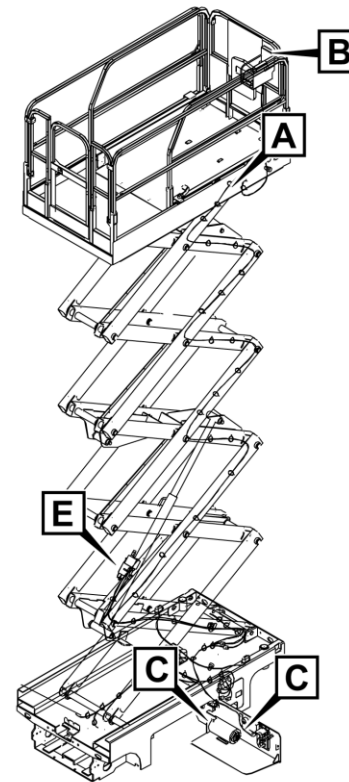
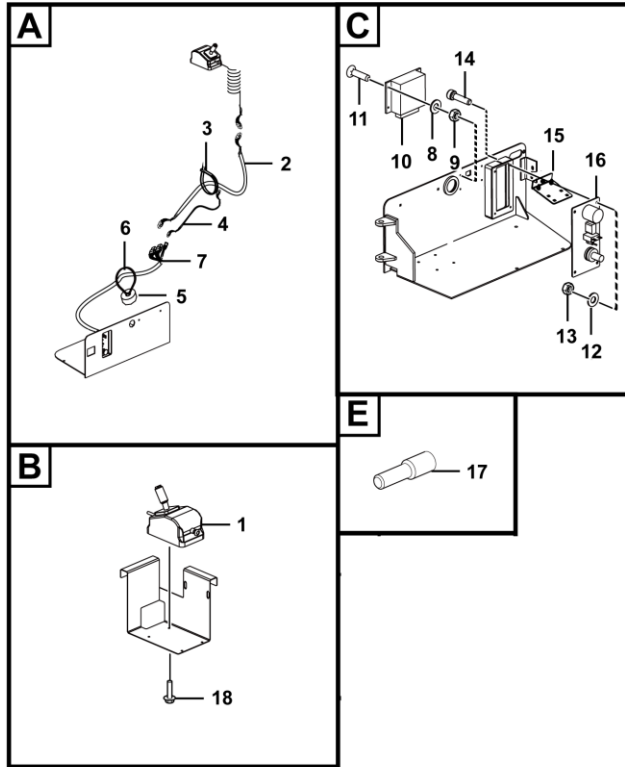

M2900-253000976.S

Key	Part No.	Description	Spare parts Y/N	Qty	Remarks
1	4130001286	Platform controller	Y	1	
2	25300000351	Pcu harness,main harness-platform controller	Y	1	
3	4190000020	Cable tie lg13-zs4*250	N	50	
4	25300007771	Wire	Y	1	
5	4120000226	Spacer ring	Y	8	
6	4190000145	Tie 8*430	Y	8	
7	25300009951	Wire	Y	1	
8	4015010290	Washer gb97.1-4flznyc-480	Y	4	
9	4013010304	Nut gb6170-m4flznyc-8-480	Y	4	
10	4130702417	Ecu	Y	1	
11	4014010126	Screw gb70.3-m4*16flznyc-8.8-480	Y	4	
12	4015010284	Washer gb97.1-6flznyc-480	Y	6	
13	4013010299	Nut gb889.1-m6flznyc-8	Y	6	
14	4014010338	Screw gb70.3-m6*20flznyc-8.8-480	Y	4	
15	25300000061	Forming (stamping, etc.), plate, for fixing ground controller	Y	1	
16	4130001287	Ground control panel	Y	1	
17	4130701538	Pressure sensor	Y	1	
18	4011010754	Bolt gb16674-m6*12flznyc-8.8	Y	4	

Platform controller

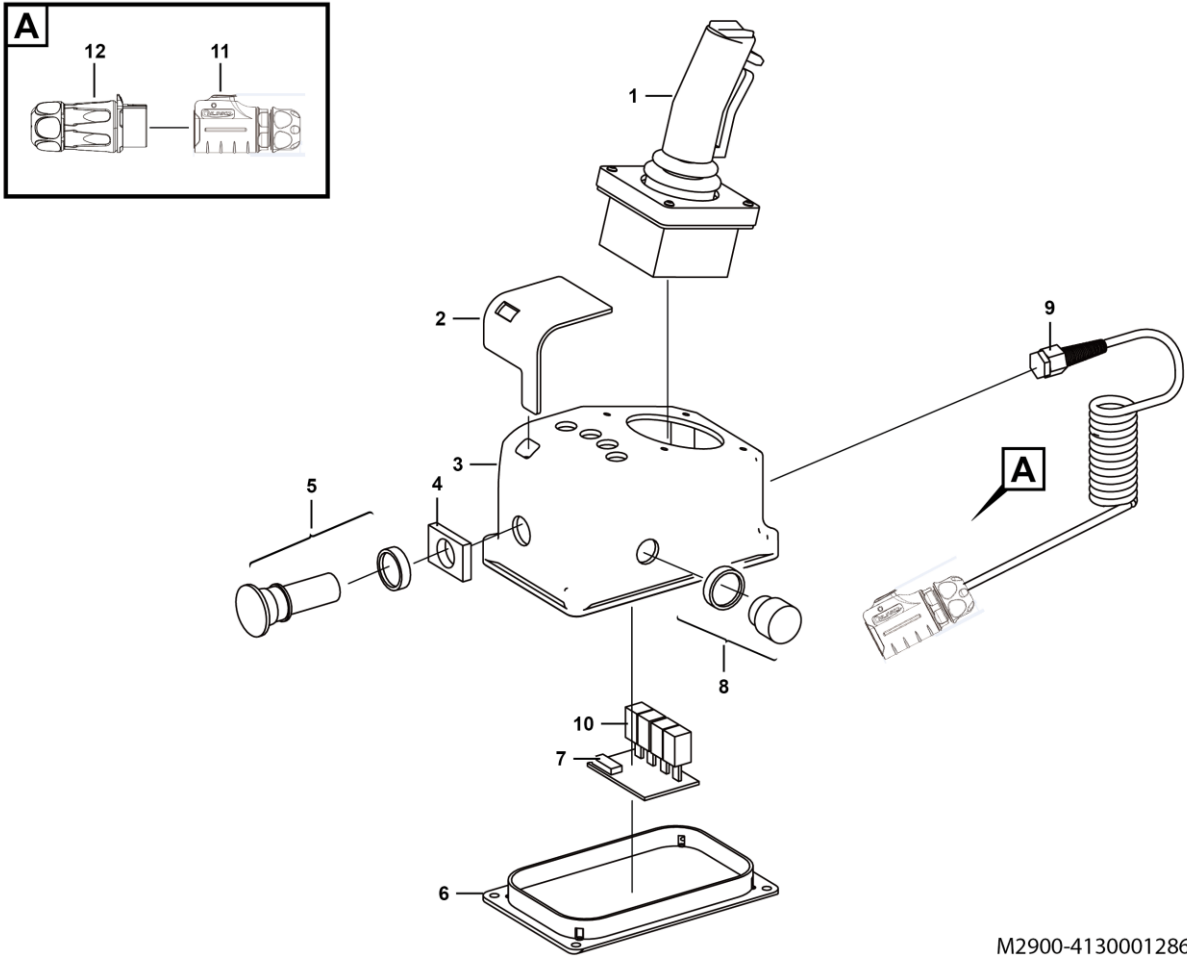

M2900-4130001286

Key	Part No.	Description	Spare parts Y/N	Qty	Remarks
1	4130000862002	Platform controller handle	Y	1	
2	4130000862001	Platform controller sticker	Y	1	
3	4130000862003	Box body	Y	1	
4	4130000862004	Emergency stop switch base	Y	1	
5	4130000862005	Emergency stop switch cap	Y	1	
6	4130000862006	Box cover	Y	1	
7	4130000862007	Pcba	Y	1	
8	4130000862008	Buzzer	Y	1	
9	4130001046009	Spring harness 200011	Y	1	
10	4130000862010	Button cap	Y	1	
11	25300003281	Cnlinko connector (upper controller end), platform controller	Y	1	
12	25300003271	Cnlinko connector (pcu harness end), platform controller-pcu harness	Y	1	

Ground control unit assembly

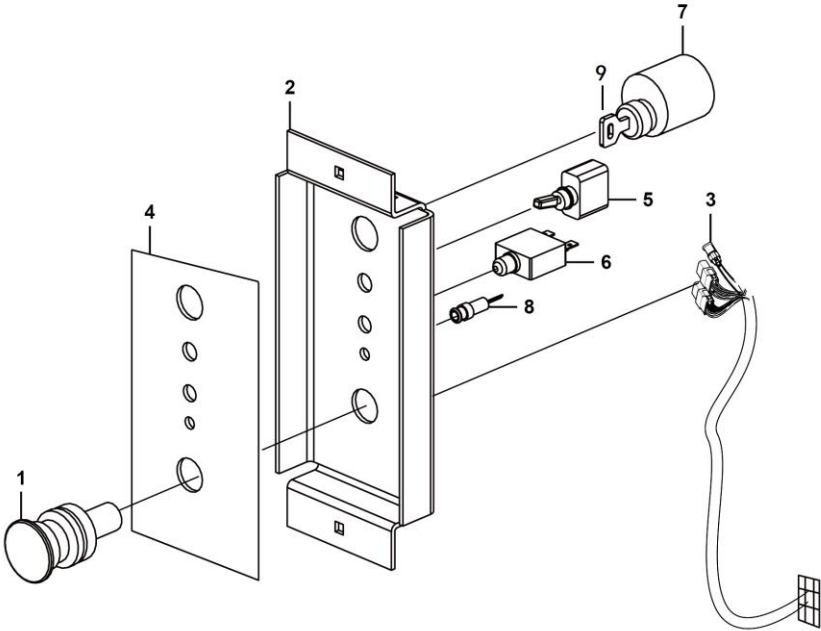

M2901-4130001287

Key	Part No.	Description	Spare parts Y/N	Qty	Remarks
1	4130001280	Emergency stop switch	Y	1	
2	4130000793	Panel	Y	1	
3	4130000795	Ground control panel harness	Y	1	
4	4130000798	Decal 100417	Y	1	
5	4130000720	Toggle switch	Y	1	
6	4130000721	7a self-reset fuse	Y	1	
7	4130000723	Key switch (key code 4130000723001)	Y	1	
8	4130000773	Overload indicator	Y	1	
9	4130000723001	Key assembly 89943-29	Y	1	



Electricity assembly

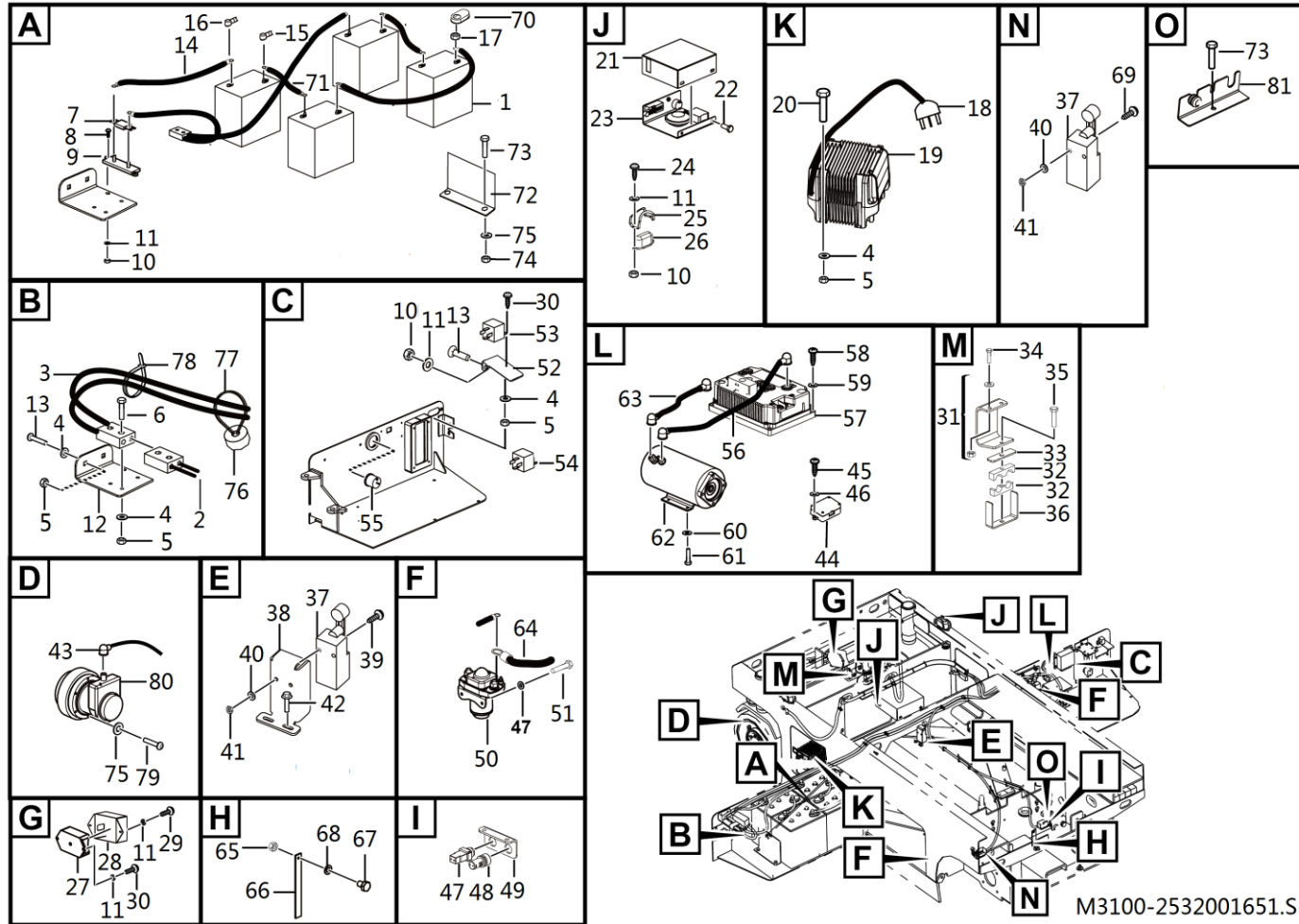

M3100-2532001651.S

Key	Part No.	Description	Spare parts Y/N	Qty	Remarks
1	4130000846	Battery t-125	Y	4	
2	25320000722	Power cord assembly, power cord assembly-fuse-battery negative	Y	1	
3	25320001862	Power cord assembly, power cord assembly-fuse-battery negative	Y	1	
4	4015010284	Washer gb97.1-6flznyc-480	Y	13	
5	4013010299	Nut gb889.1-m6flznyc-8	Y	13	
6	4011010998	Bolt gb5783-m6*35flznyc-8.8-480	Y	2	
7	4130000836	Fuse 0298300 from littelfuse	Y	1	
8	4014010133	Screw gb818-m4*16flznyc-4.8-480	Y	2	
9	4130000956	Fuse holder 02981001zxt	Y	1	
10	4013010304	Nut gb6170-m4flznyc-8-480	Y	8	
11	4015010290	Washer gb97.1-4flznyc-480	Y	17	
12	25320002191	Weldment, ce fuse fixed plate	Y	1	
13	4014010338	Screw gb70.3-m6*20flznyc-8.8-480	Y	4	
14	25320000712	Power cord p35*300, battery positive-fuse	Y	2	
15	25320015671	Power cable cap - red	Y	8	
16	25320015681	Power cable cap - black	Y	7	
17	4013010382	Ifi145-2002-hexagon flange nut 5/16-18unc-2b	Y	8	
18	25320005421	Cable	Y	1	
19	4130702292	Charger gpsc3024-lg-0x	Y	1	
20	4014010119	Screw gb70.1-m6*25flznyc-8.8-480	Y	4	
21	25320000341	Forming (stamping, etc.), protective cover, protecting electrical devices	Y	1	
22	4011011062	Bolt gb16674-m8*12flznyc-8.8-480	Y	3	

Electricity assembly

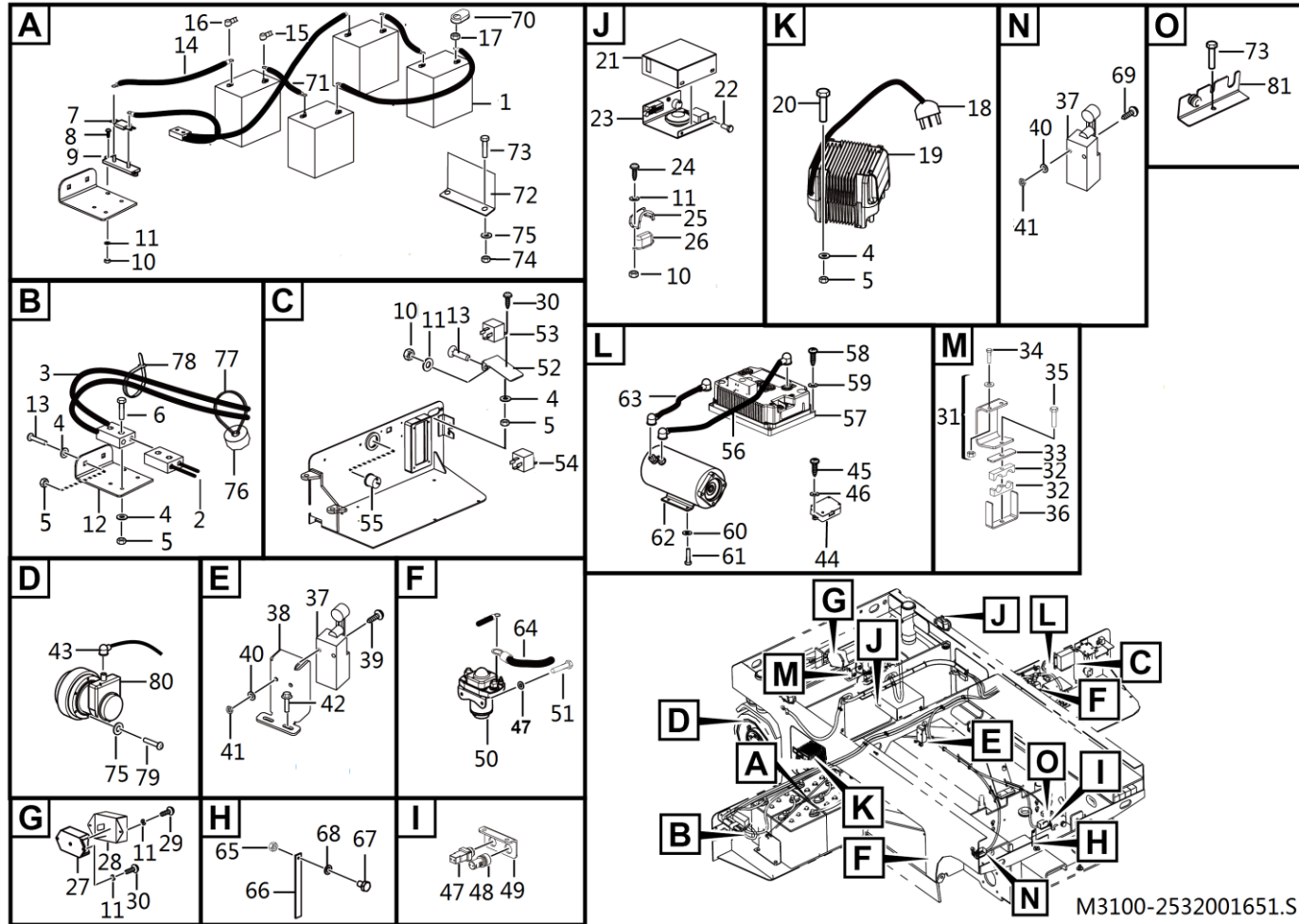

Key	Part No.	Description	Spare parts Y/N	Qty	Remarks
23	25320000391	Bracket assembly	N	1	
24	4014010121	Screw gb818-m4*20flznyc-4.8-480	Y	4	
25	25320000192	Housing, operating indicator	Y	2	
26	4130000729	Operating indicator	Y	2	
27	4130000734	Angle sensor sysa	Y	1	
28	25320000351	Weldment, angle sensor housing	Y	1	
29	4014010124	Screw gb818-m4*6flznyc-4.8-480	Y	2	
30	4014010125	Screw gb818-m4*10flznyc-4.8-480	Y	4	
31	25320005721	Forming (stamping, etc.), fixing plate assembly, drive motor harness bracket	Y	1	
32	25080000143	Pipe clamp2, for fixing hose	Y	2	
33	25080000151	Pipe clamp2, for fixing hose	Y	1	
34	4011010966	Bolt gb16674-m8*20flznyc-8.8-480	Y	2	
35	4011011058	Bolt gb16674-m8*45flznyc-8.8-480	Y	1	
36	25320003442	Forming (stamping, etc.), pressure plate,alternator harness	Y	1	
37	4130000796	Limit switch cls-121	Y	3	
38	25320000362	Weldment, plate,for protecting limit switch	Y	1	
39	4014010123	Screw gb70.1-m5*40flznyc-8.8-480	Y	2	
40	4015010283	Washer gb97.1-5flznyc-480	Y	6	
41	4013010305	Nut gb889.1-m5flznyc-8-480	Y	6	
42	4011011061	Bolt gb16674-m5*16flznyc-8.8-480	Y	2	
43	25320005643	Drive motor harness. drive motor-motor controller	Y	1	
44	4130702294	Brake coil protection box	Y	1	

Electricity assembly

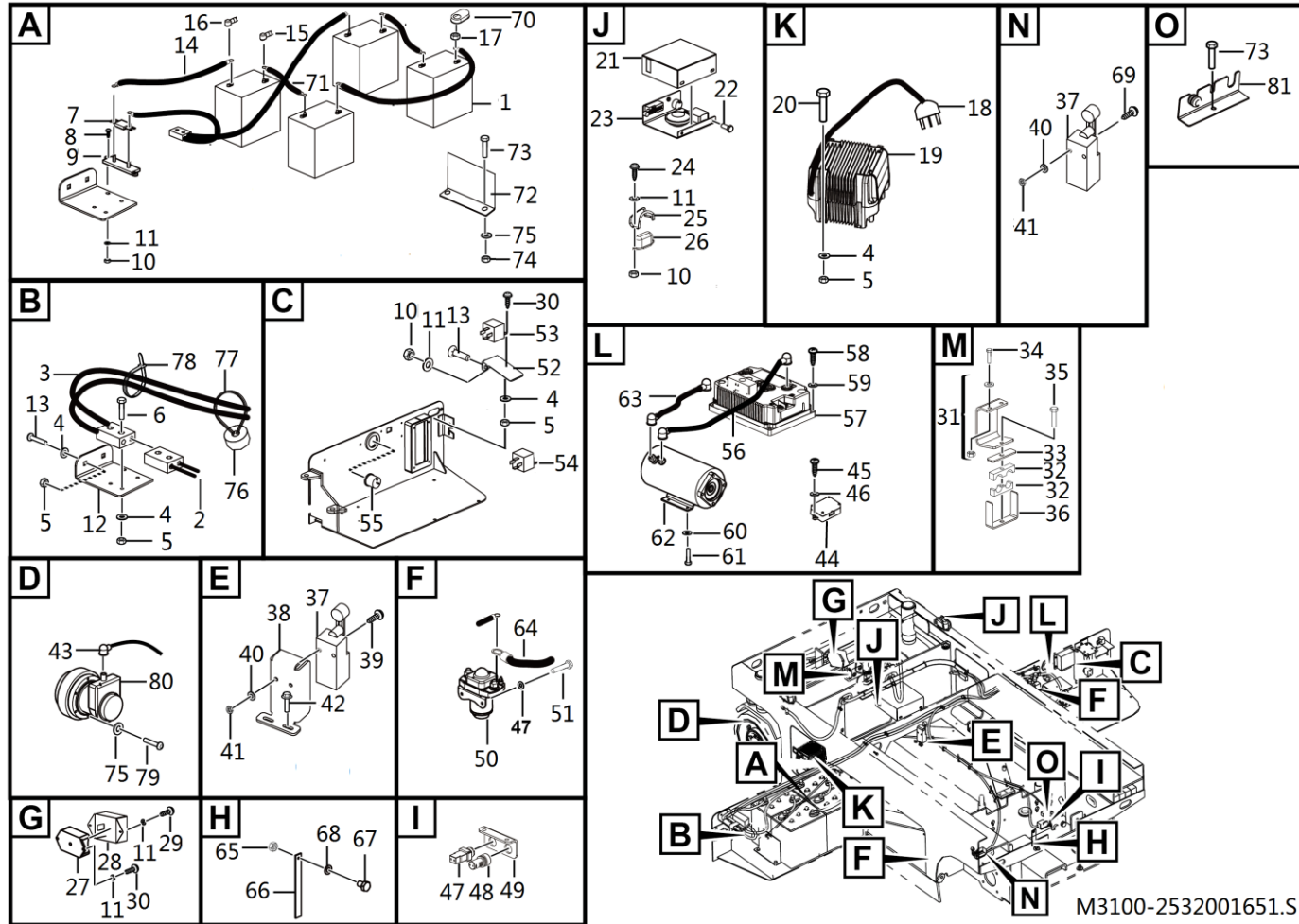

Key	Part No.	Description	Spare parts Y/N	Qty	Remarks
45	4014010463	Screw gb70.1-m3*20flznyc-8.8	Y	2	
46	4015010370	Washer gb97.1-3flznyc-300hv	Y	2	
47	4130000723	Key switch (key code 4130000723001)	Y	1	
48	4130000866	Buzzer xb2bsbc	Y	1	
49	25320016661	Plate	Y	1	
50	4130702085	Main contactor-24v	Y	1	
51	4014010355	Screw gb818-m5*10flznyc-8.8	N	2	
52	25320001571	Forming (stamping, etc.), plate,for protecting relay	Y	1	
53	4130000722	Relay	Y	1	
54	4130702007	Delay relay	Y	1	
55	4130000726	Timetable	Y	1	
56	25320001762	Power cord p35*470,controller-	Y	1	
57	4130000843	Motor controller af5ci0ba	Y	1	
58	4014010386	Screw gb818-m5*20flznyc-4.8-480	Y	4	
59	4015010345	Washer gb96.1-5flznyc-480	Y	4	
60	4015010280	Washer gb97.1-8flznyc-480	Y	4	
61	4011010424	Bolt 1/4-20unc-2b*18-10.9	Y	4	
62	4130000710	Motor ge5.5 (24v)	Y	1	
63	25320001752	Power cord p35*150, main contactor-pump motor	Y	1	
64	25320001742	Power cord p35*375, main contactor-motor controller	Y	1	
65	4013010297	Nut gb889.1-m8flznyc-8-480	Y	1	
66	25320002461	Conductive strip	Y	1	

Electricity assembly

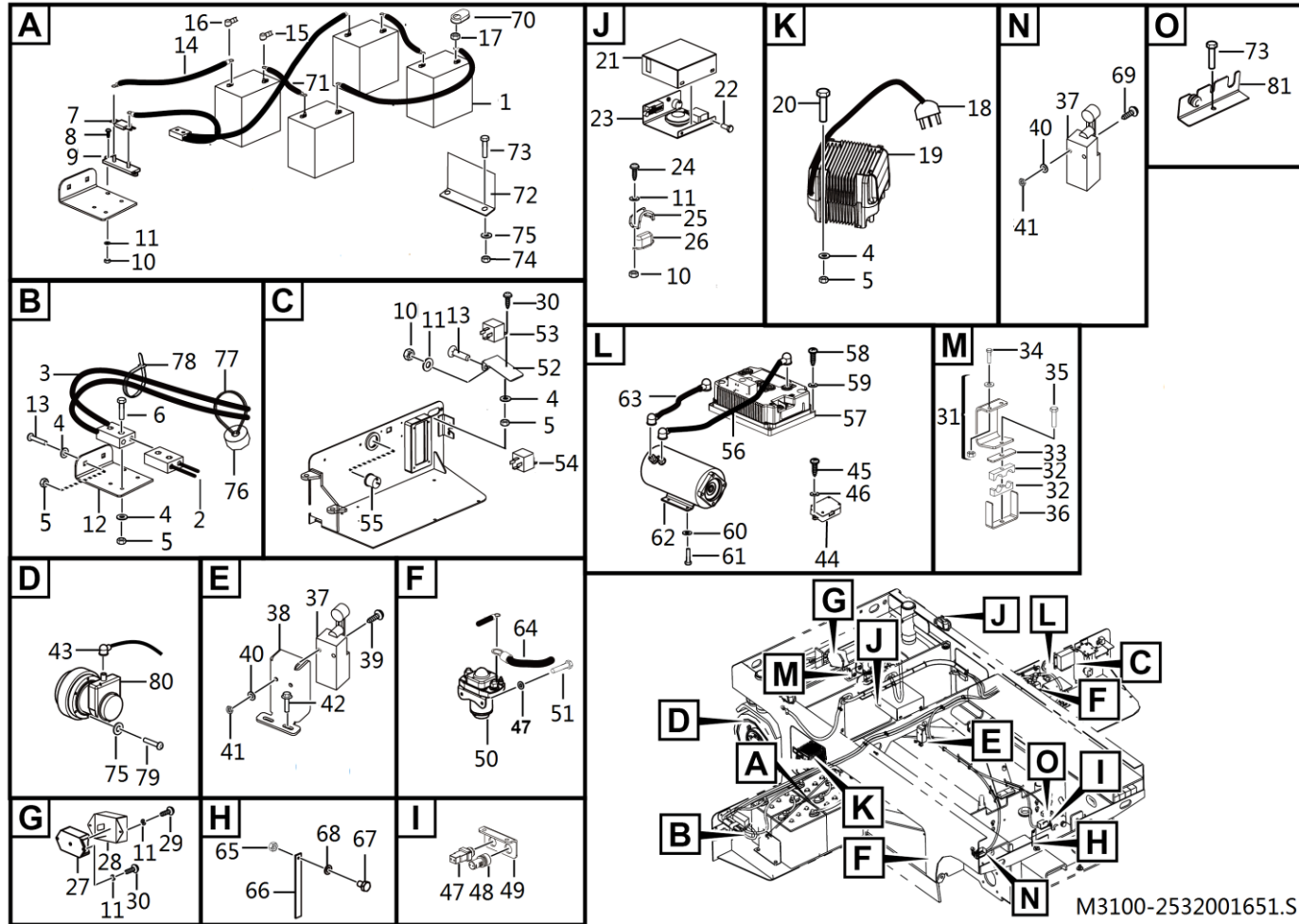

M3100-2532001651.S

Key	Part No.	Description	Spare parts Y/N	Qty	Remarks
67	4011011059	Bolt gb12-m8*30flznyc-8.8-480	Y	1	
68	4015010289	Washer gb96.1-8flznyc-480	Y	2	
69	4014010353	Screwgb70.1-m5*45flznyc-8.8	Y	4	
70	25320000171	Terminal cover	Y	8	
71	25320000662	Battery - fuse	Y	2	
72	25320000061	Forming (stamping, etc.),plate,for fixing battery	Y	1	
73	4011011015	Bolt gb16674-m10*25flznyc-8.8-480	Y	4	
74	4013010296	Nut gb889.1-m10flznyc-8	Y	2	
75	4015010339	Washer gb97.1-10flznyc-300hv-480	Y	2	
76	4120000226	Spacer ring	Y	7	
77	4190000145	Tie 8*430	Y	7	
78	4190000020	Cable tie lg13-zs4*250	N	20	
79	4011010513	Bolt 3/8-16unc-2b*32-10.9	Y	12	
80	4130702145	Drive motor assembly 0.81kw	Y	2	
81	25080000041	Plate	Y	1	

Bracket assembly

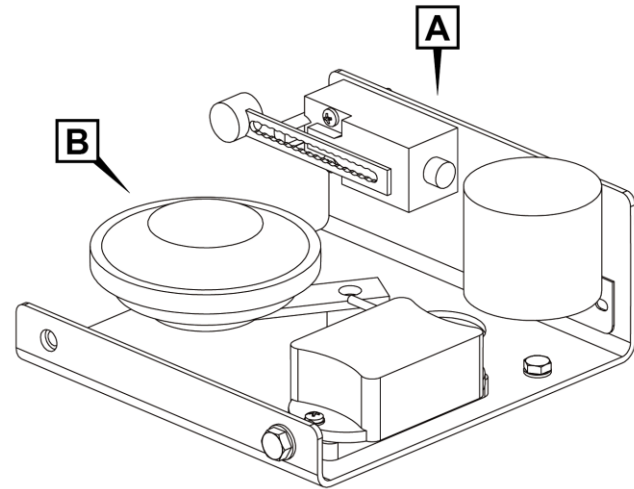
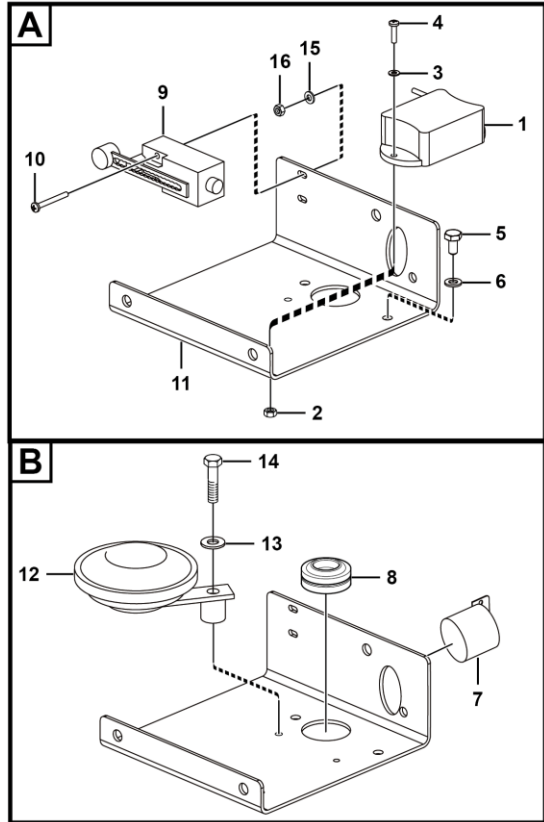

M3102-2532000039.B1c

Key	Part No.	Description	Spare parts Y/N	Qty	Remarks
1	4130000808	Tilt switch syst-1.5-3	Y	1	
2	4013000025	Nut gb6170-m4epzn-8	Y	2	
3	4015000135	Washer gb97.1-4epzn-300hv	Y	4	
4	4014000021	Screw gb818-m4*12epzn-4.8	Y	2	
5	4011000276	Bolt gb5783-m6*25epzn-8.8	Y	3	
6	4015000207	Washer gb97.1-6epzn-300hv	Y	3	
7	4130000797	Buzzer,cy-3631-24v	Y	1	
8	28179900031	Rubber gromet,40*5	Y	1	
9	4130000796	Limit switch cls-121	Y	1	
10	4014010052	Screw gb70.1-m5*40epzn-8.8	Y	2	
11	25320000321	Weldment, bracket assembly, protecting limit switch, horn, inclination switch, buzzer and other electrical devices	Y	1	
12	4130001193	Single-cone horn dl125-100lw-04	Y	1	
13	4015000315	Washer gb97.1-8-300hv	Y	1	
14	4011000180	Bolt gb5783-m8*12epzn-8.8	Y	1	
15	4015000110	Washer gb97.1-5epzn-300hv	Y	2	
16	4013000212	Nut gb889-m5epzn-8	Y	2	

Gear box

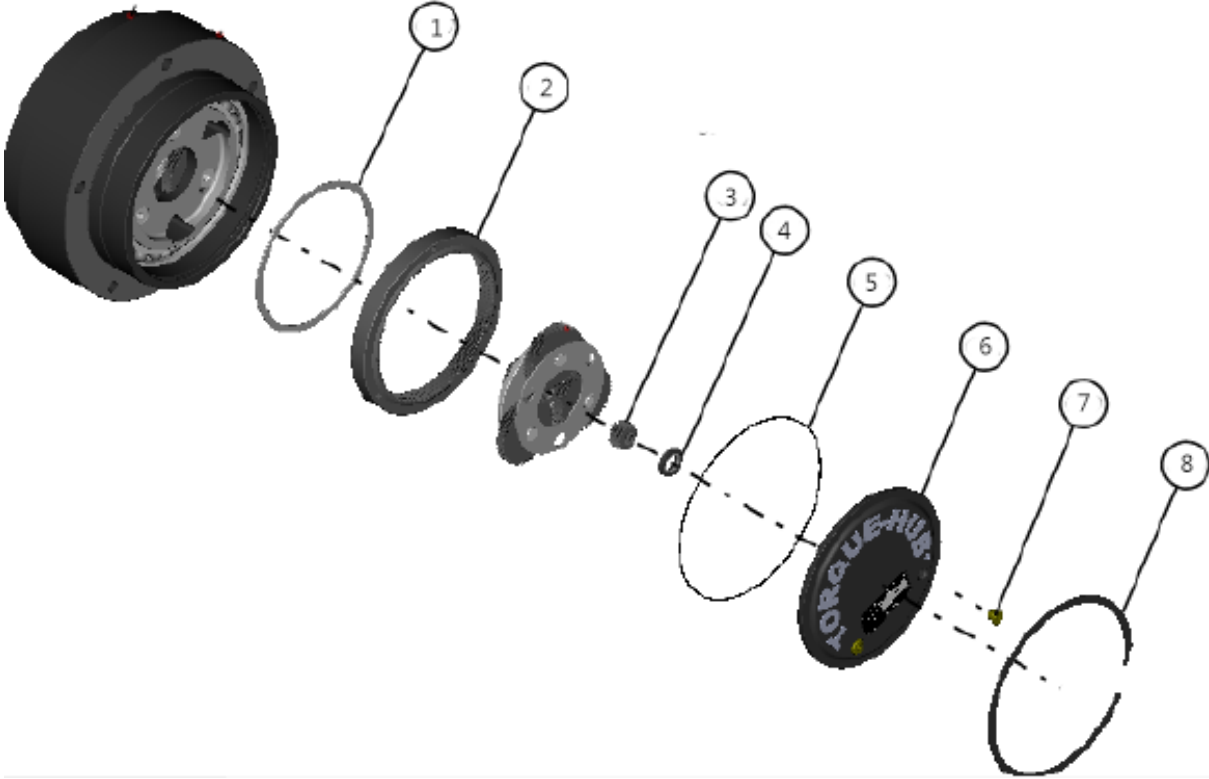

Key	Part No.	Description	Spare parts Y/N	Qty	Remarks
1	4130702145058	Ret,ring-ext (5.118,ws511)	N	1	
2	4130702145044	Gear,ring	Y	1	
3	4130702145036	Gear,sun	Y	1	
4	4130702145048	Washer,thrust	N	1	
5	4130702145060	O-ring (-165,165mm,3mm) nbr70	N	1	
6	4130702145045	Cover,platet	N	1	
7	4130702145047	Pipe plug,o ring	N	1	
8	4130702145056	Ret,ring-int (6.500,vh650)	Y	1	

Input carrier assembly

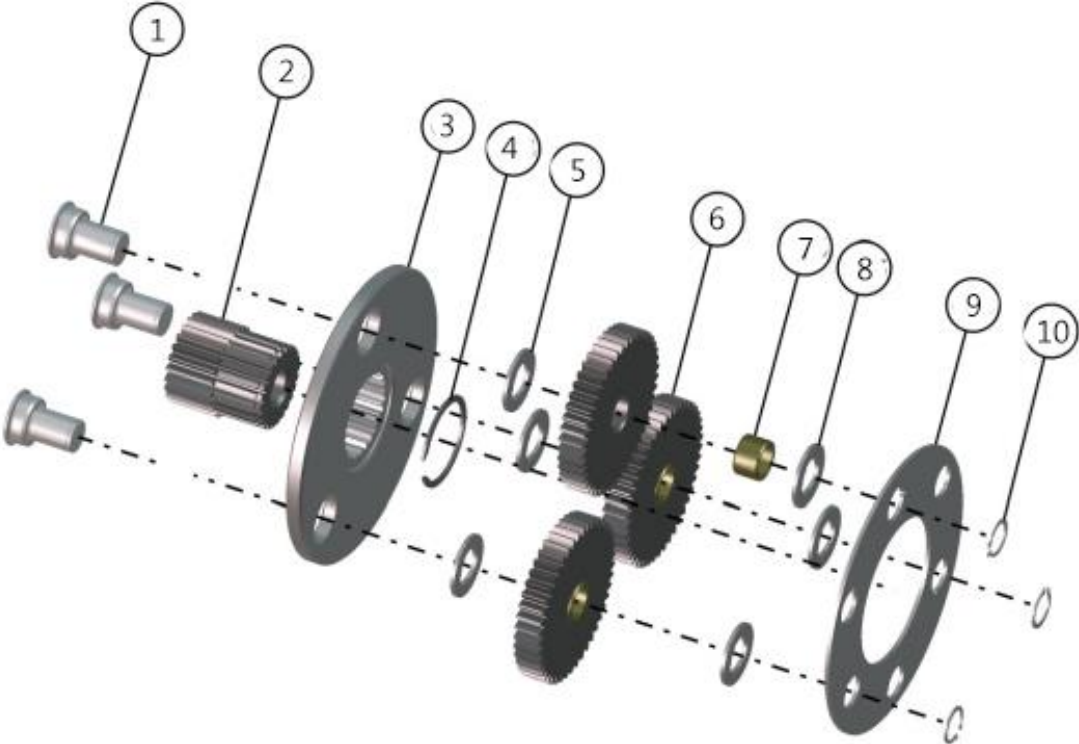

Key	Part No.	Description	Spare parts Y/N	Qty	Remarks
1	4130702145038	Shaft,plane	N	3	
2	4130702145037	Gear,sun	N	1	
3	4130702145039	Carrier	N	1	
4	4130702145057	Ret,ring-ext (1.188,xan118)	N	1	
5	4130702145062	Washer,thrust	N	3	
6	4130702145040	Gear,planet	Y	1	
7	4130702145052	Bushing,steel (.4713)	Y	1	
8	4130702145062	Washer,thrust	N	3	
9	4130702145063	Plate,thrust	Y	1	
10	4130702145059	Ret,ring-ext (.469,510046)	N	3	

Hub disassembly



Spindle assembly

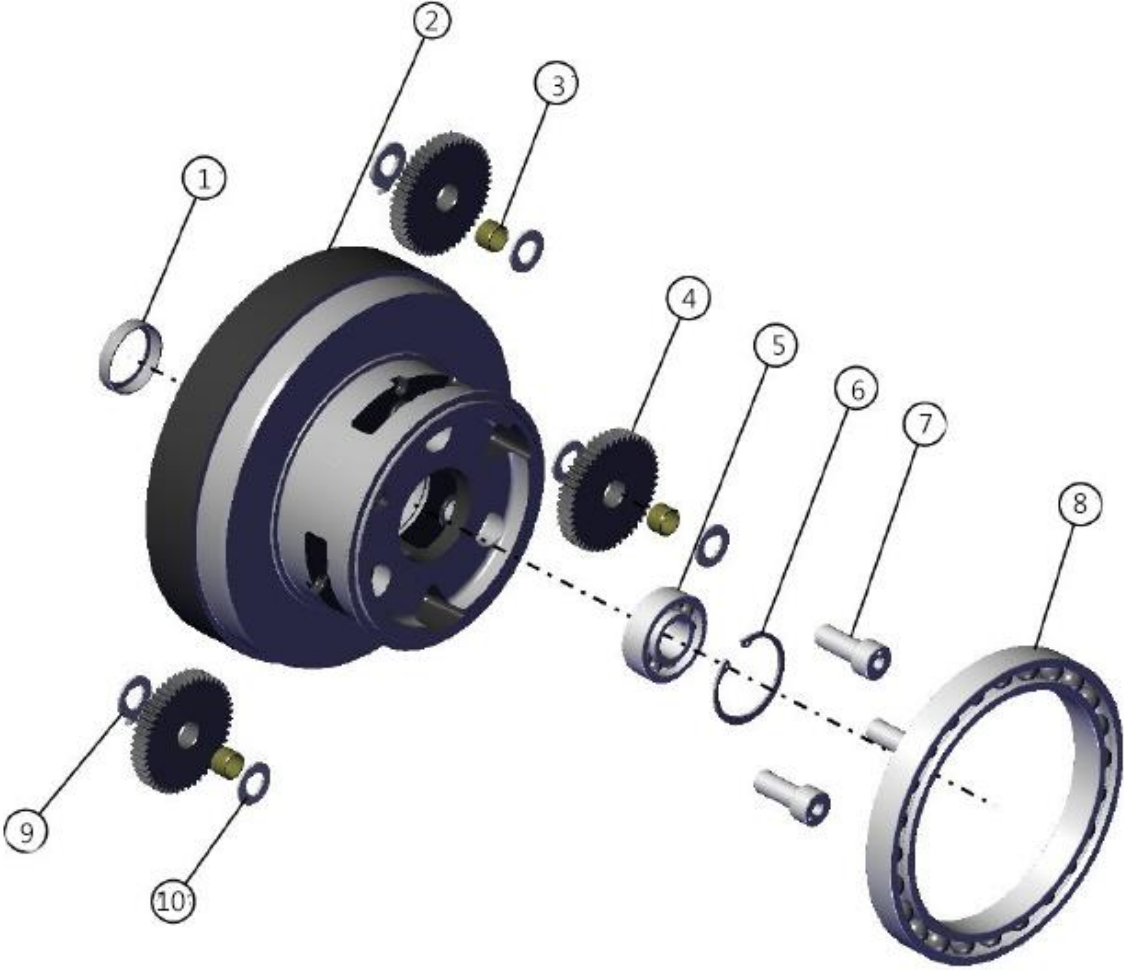

Key	Part No.	Description	Spare parts Y/N	Qty	Remarks
1	4130702145054	Seal,lip (9613,.969)	Y	1	
2	4130702145043	Spindle/carrier	N	1	
3	4130702145052	Bushing,steel (.4713)	Y	6	
4	4130702145041	Gear,planet	N	3	
5	4130702145051	Brg,ball (6204.llu)	N	1	
6	4130702145055	Ret,ring-int (1.850,n5000187)	N	1	
7	4130702145042	Shaft,planet	Y	3	
8	4130702145050	Brg,ball (6826)	Y	1	
9	4130702145061	Washer,thrust	N	3	
10	4130702145062	Washer,thrust	N	9	

Electric assembly

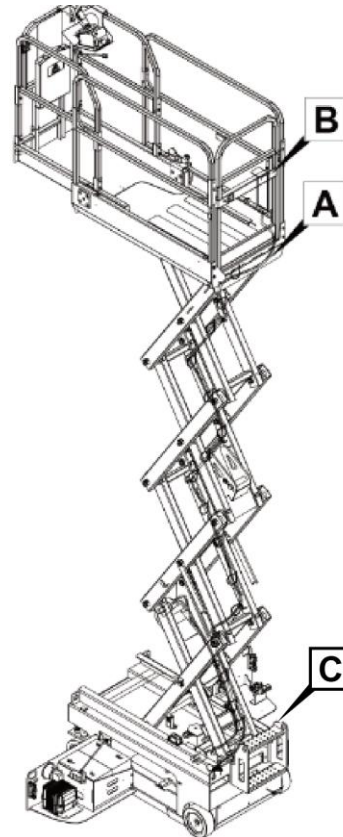
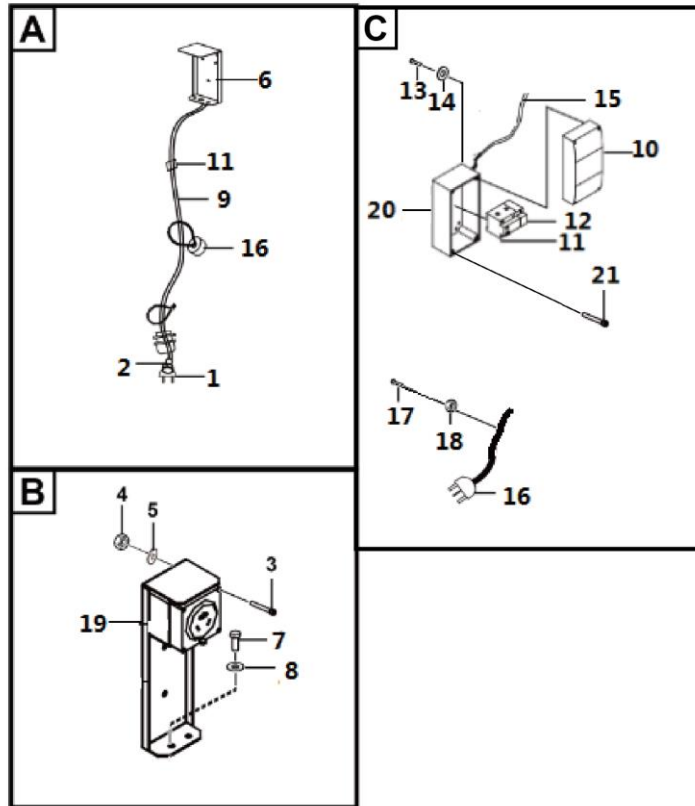

M3200-2533000681.S1B

Key	Part No.	Description	Spare parts Y/N	Qty	Remarks
1	4130702374	Device plug	Y	1	
2	4019010267	Waterproof fitting 467315-m25	Y	4	
3	4014010450	Screw gb818-m6*25flznyc-4.8	Y	4	
4	4013010299	Nut gb889.1-m6flznyc-8	Y	7	
5	4015010284	Washer gb97.1-6flznyc-480	Y	10	
6	25330006741	Ac plate	Y	1	
7	4011010746	Bolt gb5783-m8*12flznyc-8.8-480	Y	2	
8	4015010280	Washer gb97.1-8flznyc-480	Y	2	
9	25330006981	Wire	Y	1	
10	4130701803	Fuse box56cb1-4n	Y	1	
11	4130701801	Circuit breaker ic65n	Y	1	
12	4130701802	Residual current action protection accessoryvigiic65	Y	1	
13	4014010131	Screw gb70.1-m5*16flznyc-8.8-480	Y	4	
14	4015010283	Washer gb97.1-5flznyc-480	Y	8	
15	25330007001	Wire	Y	1	
16	4130702352	Plug	Y	1	
17	4014010128	Screw gb70.1-m5*25flznyc-8.8-480	Y	4	
18	4013010305	Nut gb889.1-m5flznyc-8-480	Y	4	
19	25340018031	Label - warning, power to platform	N	1	
20	25330009711	Plate welding	Y	1	
21	4014010132	Screw gb70.1-m6*20flznyc-8.8-480	Y	3	

